



Standard Drawings

THE CONSTRUCTION STANDARDS AND DRAWINGS HAVE BEEN PREPARED TO AID ENGINEERS AND DEVELOPERS IN THE PREPARATION OF DEVELOPMENT PLANS AND ENGINEERING DESIGN AND TO INFORM INTERESTED PERSON OF THE PROCEDURES AND STANDARDS FOR THE CITY OF PIQUA, OHIO. IT IS ALSO INTENDED TO BE USED DURING RECONSTRUCTION OR REPLACEMENT OF EXISTING FACILITIES OR ANY CONSTRUCTION WITHIN THE CITY RIGHT-OF-WAY. THE RULES, STANDARDS, SPECIFICATIONS, CRITERIA, ETC. ARE TO SUPPLEMENT ANY APPLICABLE ZONING REGULATION AND THE CITY OF PIQUA SUBDIVISION REGULATIONS OF THE CITY OF PIQUA.

IT IS NOT THE INTENT OF THE CONSTRUCTION STANDARDS AND DRAWINGS TO TAKE AWAY FROM THE DESIGNING ENGINEER ANDY RESPONSIBILITY FOR THE TECHNICAL ADEQUACY OF THIS DESIGN OR FREEDOM TO USE HIS ENGINEERING JUDGMENT AND DISCRETION. IT IS RECOGNIZED THAT MATTERS OF ENGINEERING DESIGN CANNOT BE SET OUT IN WRITING TO COVER ALL SITUATIONS; HOWEVER THE CONSTRUCTION STANDARDS AND DRAWINGS AS SET OUT HEREIN REPRESENT GOOD CONSTRUCTION STANDARDS AND DRAWINGS AS SET OUT HEREIN REPRESENT GOOD ENGINEERING PRACTICE. ANY DESIGN METHODS OR CRITERIA DIFFERENT THAN THAT LISTED WILL RECEIVE CONSIDERATION FOR APPROVAL, PROVIDED THE PROPOSED VARIANCES AND THE REASONS FOR THEIR USE ARE SUBMITTED TO THE CITY FOR THE CITY ENGINEER'S APPROVAL.

THE CITY, AT ANY TIME DURING THE DESIGN OR CONSTRUCTION, SHALL HAVE THE AUTHORITY TO MODIFY ANY ENGINEERING OR CONSTRUCTION DETAIL, WHENEVER REQUIRED FOR THE PROTECTION OF THE PUBLIC INTEREST.

THE STANDARD SPECIFICATIONS OF THE CITY OF PIQUA AND THE STANDARD SPECIFICATIONS OF THE OHIO DEPARTMENT OF TRANSPORTATION INCLUDING CHANGES AND SUPPLEMENTS SHALL GOVERN ALL IMPROVEMENTS.

300 -ROADWAYS

STREET CLASSICATONS AND RECOMMENDED STANDARD STREET DIMENSION	300-1
TYPICAL SECTIONS AND PAVEMENT COMPOSITION	300-2
STREET DESIGN STANDARD	300-3
CONCRETE CURB DETAILS	300-4
RESIDENTIAL DRIVE APPROACH	300-5
COMMERCIAL AND INDUSTRIAL DRIVE APPROACH	300-6
DRIVE APPROACH AND CONCRETE SIDEWALK WITH NO CURB LAWN	300-7
CURB RAMPS	300-8
CONCRETE SIDEWALK DETAIL	300-9
CONCRETE SIDEWALK NOTES	300-10
ASPHALT OVERLAY AND MONUMENT	300-11
MISCELLANEOUS ROADWAY NOTES AND ALLY DETAIL	300-12
STREET CUT AND RIGHT-OF WAY OPENING STANDARD DRAWINGS AND SPECS	300-13
STREET CUT AND RIGHT-OF-WAY OPENING STANDARD DRAWINGS AND SPECS	300-14
AGGREGATE BASE, ASPHALT, CONCRETE AND SUBGRADE TESTING	300-15
STREET CLOSING AND BLOCK WAY PERMITS	300-16
DRIVE APPROACH WITH CULVERT	300-17
STREETSCAPE BRICK WITH ASPHALT LAYING COURSE TYPICAL SECTIONS	300-18
STREETSCAPE BRICK SPECIFICATIONS	300-19

500 GENERAL

GENERAL NOTES	500-1
BORING/JACKING	500-2
CASING PIPE DETAIL	500-3

CONSTRUCTION NEAR TREES	500-4
TREE CLEARANCE	500-4A
SANITARY SEWER DEMO ABANDONMENT	500-5

600 STORM DRAINAGE

TYPE 1 CATCH BASIN	600-1
TYPE 2-2-B CATCH BASIN	600-2
YARD DRAIN	600-3
TYPE 6 CATCH BASIN	600-4
TYPE 6 CATCH BASIN	600-4A
TYPE 3 STORM MANHOLE	600-5
TYPE 3 STORM MANHOLE DETAILS	600-6
FULL -HEIGHT HEADWALL	600-7
HALF-HEIGHT HEADWALL	600-8
STORM SEWER TRENCH DETAILS	600-9
MISCELLANEOUS STORM NOTES	600-10
EROSION CONTROL	600-11
TEMPORARY EROSION CONTROL SAMPLES	600-12
GEOTEXTILE-STONE INLET PROTECTION FOR CURB INLETS	600-12A
TEMPORARY EROSION CONTROL SAMPLES	600-13
REPAIR OF EXISTING FIELD TILE OR STORM PIPE DETAIL	600-14

800 WATER DISTRIBUTION

FIRE HYDRANT	800-1
RESTRAINING JOINTS AND TAPPING SLEEVES FOR WATER MAINS	800-2
CONCRETE BLOCKING FOR WATER MAINS	800-3
WATER MAIN TRENCH DETAIL	800-4

WATER MAIN MATERIAL AND TESTING	800-5
MISCELLANEOUS WATER NOTES	800-6
2" METER PIT INSTALLATION	800-7
3/4" AND 1" METER PIT INSTALLATION	800-8
CURB STOP ASSEMBLY	800-8A
COMBINATION FIRE LINE/DOMESTIC WATER METER PIT	800-9
COMBINATION FIRE LINE/DOMESTIC WATER METER PIT	800-9A
LIMITED AREA SPRINKLER SYSTEM DETAIL	800-10
REDUCED PRESSURE DETECTOR ASSEMBLY	800-11
DOUBLE DETECTOR CHECK VALVE ASSEMBLY DETAIL	800-12
STANDARD INSTALLATION FOR IRRIGATION METERS AND BACKFLOW PREVENTER	800-13
IRRIGATION DETAILS	800-14
2" FIRE LINE AND 4' LARGER FIRE LINE	800-15
2" DOMESTIC FIRE COMBINATION	800-16
FIRE LINE DETAIL NOTES	800-17
TYPE III-CUT AND PLUG DETAIL	800-18
TAPPING SLEEVE AND HYDROSTATIC TEST	800-19

900- SANITARY SEWERS

TYPE 3 SANITARY MANHOLE	900-1
TYPE 2 SANITARY DROP MANHOLE	900-2
SANITARY DROP ON EXISTING MANHOLE	900-3
SANITARY INSIDE DROP	900-3A
MISCELLANEOUS SANITARY MANHOLE DETAILS	900-4
SANITARY SEWER TRENCH DETAIL	900-5
REPAIR OF EXISTING SANITARY SEWER	900-6

CITY OF PIQUA



TABLE OF CONTENTS

REVISIONS:
05-09-18 BG

DATE APPROVED:
DEC. 2016

PAGE No.
1 - 2

SANITARY SEWER CONTINUED

SERVICE RISER AND SERVICE LATERAL FOR NEW CONSTRUCTION	900-7
SANITARY SEWER SADDLE DETAILS	900-8
SANITARY SEWER CLEANOUT DETAIL	900-9
BUILDING CONNECTION DETAIL	900-10
SANITARY SEWER TESTING NOTES	900-11
SANITARY SEWER TELEVISIONING STANDARDS	900-12
MISCELLANEOUS SANITARY SEWER NOTES	900-13
SERVICE CONNECTION LOCATION REFERENCE	900-14
SERVICE CONNECTION LOCATION REFERENCE (BUILDING IN PLACE)	900-15
MAINTENANCE OF FLOW IN EXISTING SEWERS AND DRAINS	900-16

300 - Roadways

STREET FUNCTIONAL CLASSIFICATIONS

A. ARTERIAL

A GENERAL TERM DENOTING A HIGHWAY PRIMARILY FOR THROUGH TRAFFIC, CARRYING HEAVY LOADS AND LARGE COLUMES OF TRAFFIC, USUALLY ON A CONTINUOUS ROUTE.

B. COLLECTOR

STREET DESIGNED TO CONDUCT TRAFFIC FROM LOCAL STREETS TO ARTERIALS, COLLECTOR HAS FURTHER BREAKDOWN OF COLLECTOR-RESIDENTIAL AND COLLECTOR-INDUSTRIAL AND COMMERCIAL.

C. MINOR

A STREET DESIGNED TO PROVIDE ACCESS TO ABUTTING PROPERTY TO COLLECTORS.

STREET FUNCTIONAL CLASSIFICATION	DESIRED MINIMUM STANDARDS		
	RIGHT-OF-WAY WIDTH (L.F.)	BACK-TO-BACK (L.F.)	BACK-TO-BACK CURB (L.F.)
ARTERIAL	80	59	59
COLLECTOR- RES.	60	37	41
COLLECTOR- IND. AND COMM.	60	37	41
MINOR	50	31	35

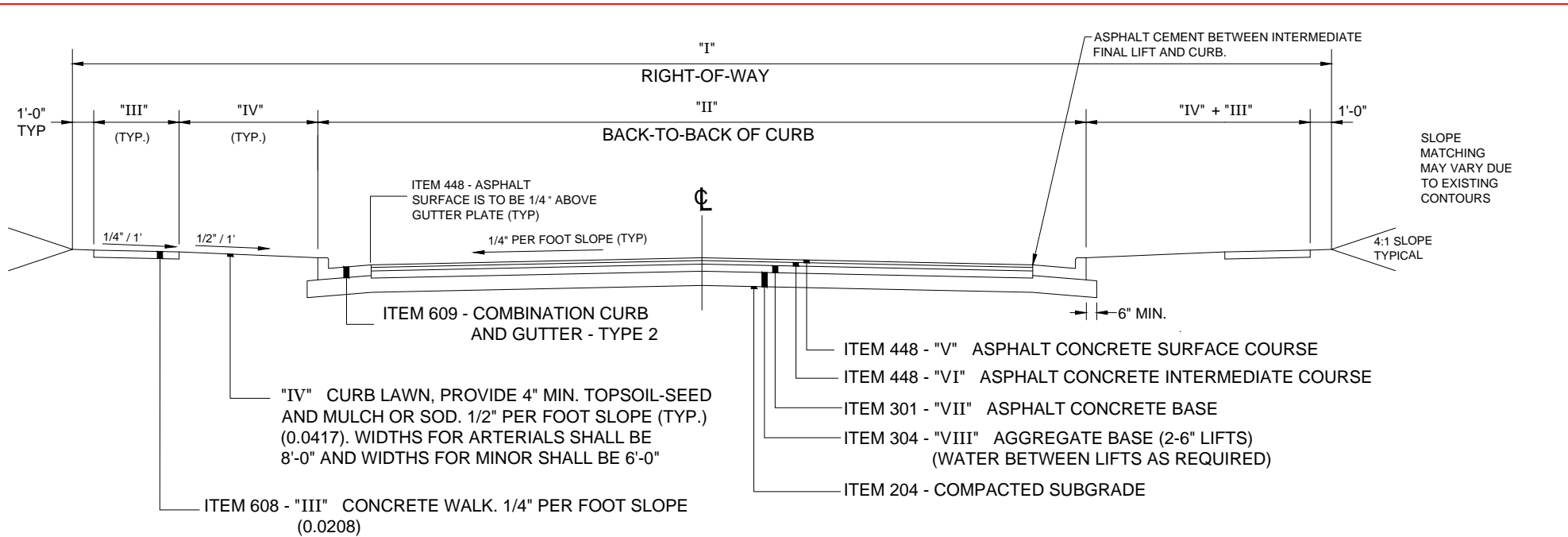

NOTES

MINIMUM STANDARDS					
ITEM	DESCRIPTION	COLLECTOR			
		ARTERIAL	COMM. & IND	RESIDENTIAL	MINOR
I	RIGHT-OF-WAY	80'	60'	60'	50'
II	B/B CURB	59'	37'	37'	31'
III	SIDEWALK WIDTH	4'	4'	4'	4'
IV	CURB LAWN	8.0'	6.5'	6.5'	6.0'
V	ITEM 448	1-1/2"	1-1/2"	1-1/2"	1-1/2"
VI	ITEM 448	1-1/2"	1-1/2"	2"	2"
VII	ITEM 301	6"	3"	---	---
VIII	ITEM 304	2-4" LIFTS	2-4" LIFTS	2-6" LIFTS	2-5" LIFTS

- A. ALL WORK TO CONFORM TO ODOT CONSTRUCTION AND MATERIAL SPECIFICATIONS LATEST REVISION UNLESS OTHERWISE SPECIFIED.
- B. ITEM 407 TACK COAT, SHALL BE REQUIRED WHEN 10 DAYS HAVE ELAPSED BETWEEN ASPHALT PLACEMENT LIFTS UNLESS OTHERWISE SPECIFIED BY THE CITY. APPLICATION RATE IS 0.10 GALLON PER SQUARE YARD.
- C. ALL BUTT JOINTS SHALL BE SEALED WITH PG64-22 WITHIN 24 HOURS AFTER PLACEMENT OF ITEM 448
- D. NO CONCRETE PAVEMENT WILL BE ACCEPTED

TYPICAL STREET AND CUL-DE-SAC PLAN

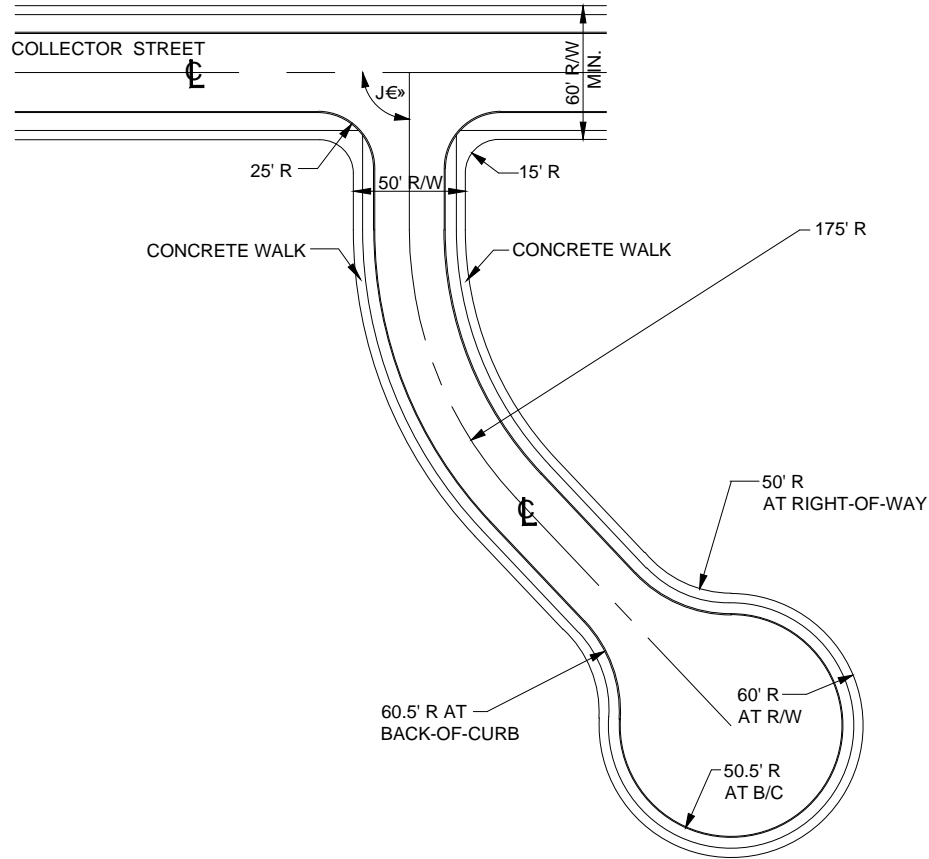

MINIMUM STREET DESIGN STANDARDS

	25 MPH MINOR (THU STREETS)	35 MPH COLLECTOR	45 MPH ARTERIAL
MINIMUM CENTERLINE GRADES	.50%	.50%	.50%
MAXIMUM CENTERLINE GRADES	10%	7%	4%
MINIMUM LENGTH OF VERTICAL CURVE (SEE NOTE A)	50FT	50FT	100FT
MINIMUM CENTERLINE RADIUS	250FT	400FT	600FT
MINIMUM LENGTH TANGENT BETWEEN CURVES	50FT	50FT	100FT
MINIMUM BACK- OF-CURB RADIUS	25FT	25FT	50FT
MINIMUM HORIZONTAL VISIBILITY	200FT	300FT	500FT
MINIMUM STOPPING SIGHT DISTANCE (MEASURED FROM 3.5' EYE-LEVEL TO 6" OBJECT HEIGHT)	200FT	300FT	500FT
CROSSROAD GRADE-STOP CONDITION-WITHIN 100' OF AN INTERSECTION.	3%	3%	3%
RIGHT-OF-WAY WIDTH	50FT	60FT	80FT

NOTES

- A. MINIMUM LENGTH OF VERTICAL CURVE CAN BE REDUCED OR ELIMINATED TO ALLOW FOR PROPER DRAINAGE, WITH APPROVAL.

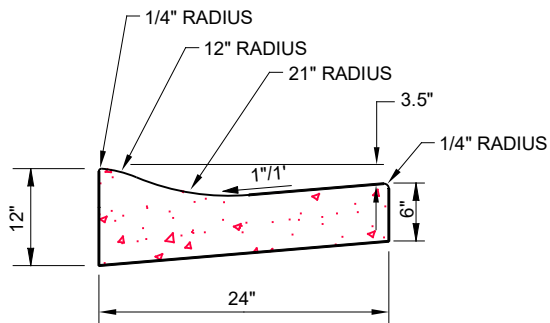

**CITY OF PIQUA
TYPE 1 CURB**

NOTE:
FOR THE TYPE 1 CURB,
THERE SHALL BE 3.5" FROM
THE TOP OF CURB TO THE
FACE OF GUTTER.

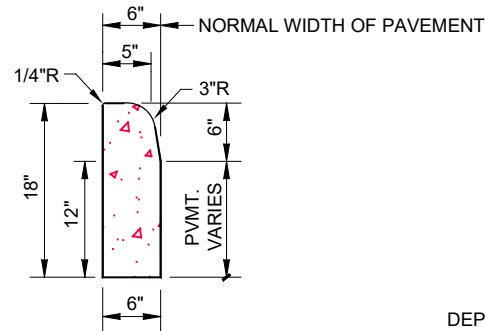

**TYPE 6
BARRIER CURB**

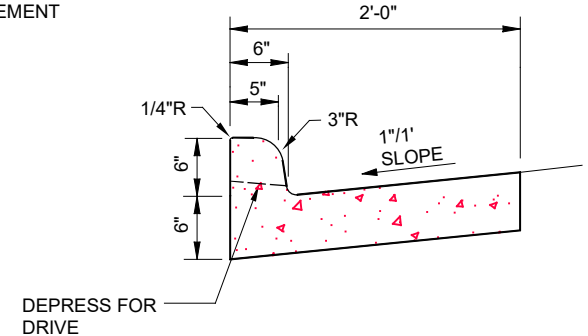

**TYPE 2 COMBINATION
CURB AND GUTTER**

NOTES

- A. CONCRETE AND WORK SHALL MEET THE REQUIREMENT SET FORTH IN ODOT ITEM 609 CURBING.
- B. CURBING SHALL HAVE CONTRACTION JOINTS EVERY 10'.
- C. MINIMUM OF 6" OF ODOT 304 SHALL BE PLACED UNDER CURBING.
- D. CURBING SHALL BE BACKFILLED IMMEDIATELY AFTER FORMS ARE REMOVED OR AS SOON AS PRACTICAL WHEN SLIP FORMING PRIOR TO OTHER CONSTRUCTION OPERATIONS.
- E. PROVIDE BROOM FINISH AND EDGING TO ALL EXPOSED SURFACES.
- F. WITH PRIOR CITY DIRECTION, APPLY WHITE PIGMENTED CURING COMPOUND ON ALL SURFACES IMMEDIATELY AFTER FINISHING SURFACES.
- G. ALL CONCRETE SHALL BE ODOT CLASS QC1, (4000 PSI, 520 LB/CY CEMENT) PROPORTIONING OPTIONS 1,2, AND 3 NOT ALLOWED.
- H. CONCRETE SHALL CONTAIN 7% ± 2% OF TOTAL AIR.
- I. ALL CURBING PLACED SHALL HAVE A FRONT AND REAR FORM. EXCEPTION: UNLESS CURBING IS SLIP FORMED BY MACHINE OR IS ABUTTING CONCRETE DRIVEWAY OR SIDEWALK OR OTHERWISE APPROVED BY THE ENGINEER.
- J. MINIMUM FLOW LINE SLOPE OF THE PERFORATED PIPE IS TO BE 0.003 FT/FT TO OUTLET.

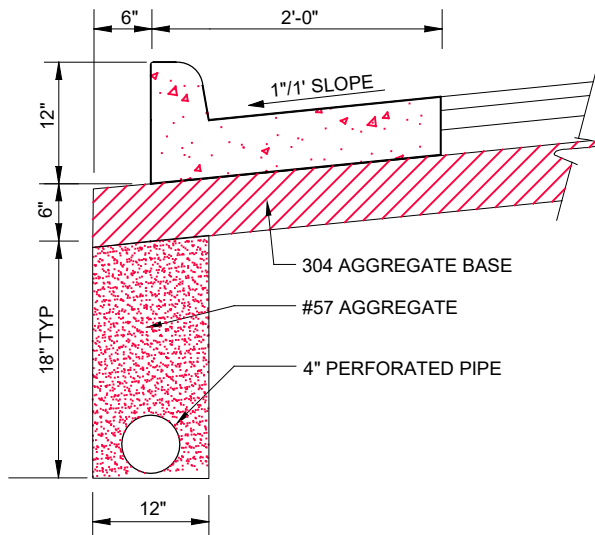

**4" SHALLOW PIPE UNDERDRAIN DETAIL
(AS REQUIRED BY CITY)**

CITY OF PIQUA



CONCRETE CURB DETAILS

REVISIONS:
11-11-19 BG
12-31-20 BG/KK

DATE APPROVED:
DEC. 2016

PAGE No.
300-4

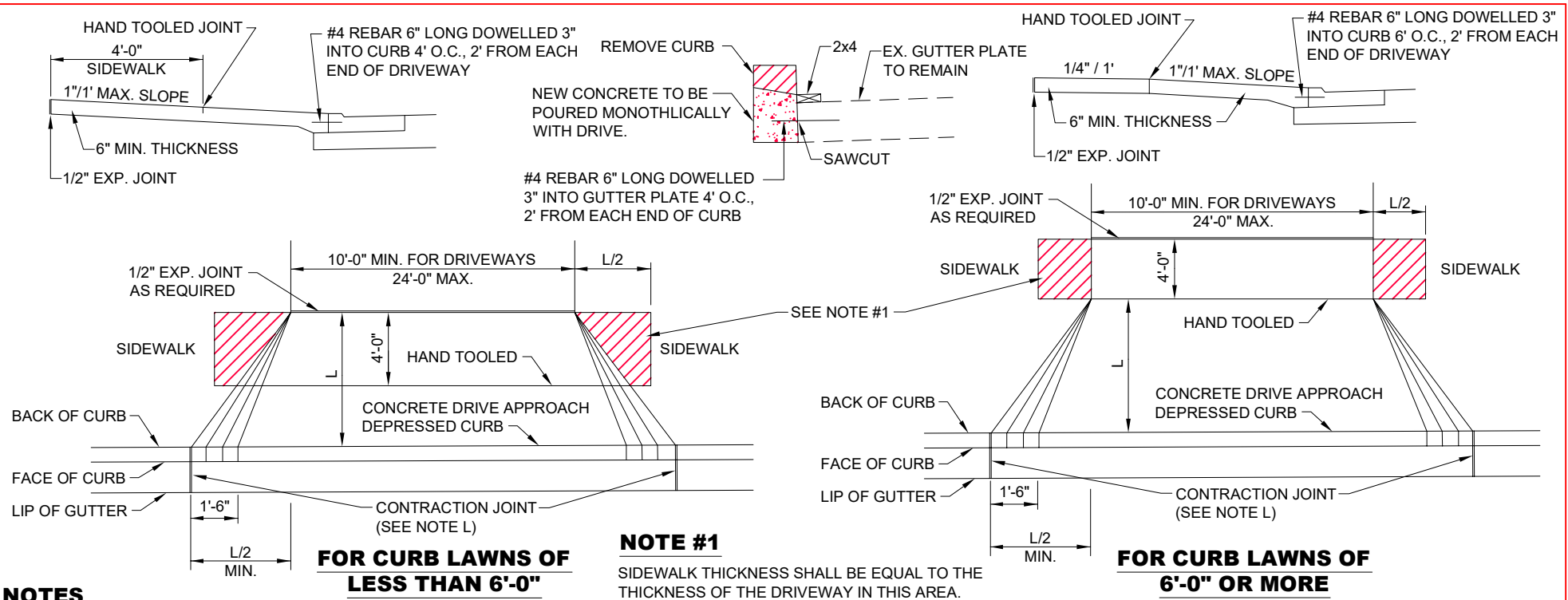

NOTES

- A. DRIVE APPROACHES SHALL MEET THE REQUIREMENTS OF ODOT ITEM 452, 499, 608, AND 609 CAST IN-PLACE CONCRETE
- B. DRIVE APPROACHES MAY BE PLACED MONOLITHICALLY WITH CURB.
- C. MAXIMUM JOINT SPACING SHALL BE 10' LONGITUDINALLY, TRANSVERSELY AND AT TAPERS.
- D. EXPANSION MATERIAL SHALL BE 1/2" PREMOLDED, ODOT APPROVED.
- E. 6" OF COMPACTED ODOT ITEM 304, ITEM 411 OR 57'S AGGREGATE BASE SHALL BE PLACE UNDER DRIVE APPROACHES.
- F. PROVIDED BROOM FINISH AND EDGING TO ALL EXPOSED SURFACES.
- G. WHERE CURB AND GUTTER HAS NOT BEEN DROPPED AT DRIVE APPROACHES, THE CONTRACTOR WILL CUT AND REMOVE CURB. (SEE DETAIL)
- H. WHERE ASPHALTIC CONCRETE PAVEMENT HAS BEEN DISTURBED, THE ASPHALT SHALL BE REPLACED BY THE CONTRACTOR AS DIRECTED BY THE CITY.
- I. JOINTS SHALL BE CLEANED AND EDGED BY A 1/4" RADIUS EDGER. LONGITUDINAL JOINTS SHALL BE AS DIRECTED BY THE CITY. EXPANSION JOINTS SHALL BE OF SUCH DIMENSIONS AS SHOWN ON STANDARD DEAWINGS FOR CONSTRUCTION JOINTS.
- J. CONCRETE SHALL CONTAIN 6% ± 2% OF TOTAL AIR.
- K. CONCRETE SHALL BE ODOT CLASS QC1.
- L. THIS STANDARD DRAWING IS FOR GUIDELINE PURPOSES. EACH INDIVIDUAL DRIVE WILL NEED TO BE DESIGNED AND SUBMITTED TO THE CITY FOR REVIEW AND APPROVAL
- M. "W"=10' MINIMUM TO 24' MAXIMUM UNLESS OTHERWISE APPROVED BY THE CITY.
- N. IF CURB IS REMOVED AND REPLACED DURING DRIVEWAY CONSTRUCTION, JOINTS BETWEEN EXISTING AND NEW CURB ARE TO BE DOWELLED WITH #4 REBAR 6" IN LENGTH, 3" INTO CURB, 4" OC.
- O. ALL NEW CONSTRUCTION OR MODIFICATIONS OF DRIVE APPROACHES REQUIRE A CONCRETE APPROACH; REGARDLESS OF WHETHER THERE IS A SIDEWALK OR NOT. THE NEW APPROACH IS TO GO FROM EDGE OF THE EXISTING STREET TO RIGHT OF WAY OR MINIMUM OF 6'-0"
- P. DRAINAGE ISSUES WILL HAVE TO BE ADDRESSED, WHEN A DRIVEWAY IS INSTALLED OR MODIFIED.
- Q. PRECAUSTIONS SHALL BE TAKEN TO PROTECT EXISTING CONCRETE, BRICK FROM TIRE MARKS AND DAMAGE DURING CONSTRUCTION.

RESIDENTIAL DRIVE APPROACH

REVISIONS:	DATE APPROVED: DEC. 2016
BG 9-27-16	PAGE No. 300-5

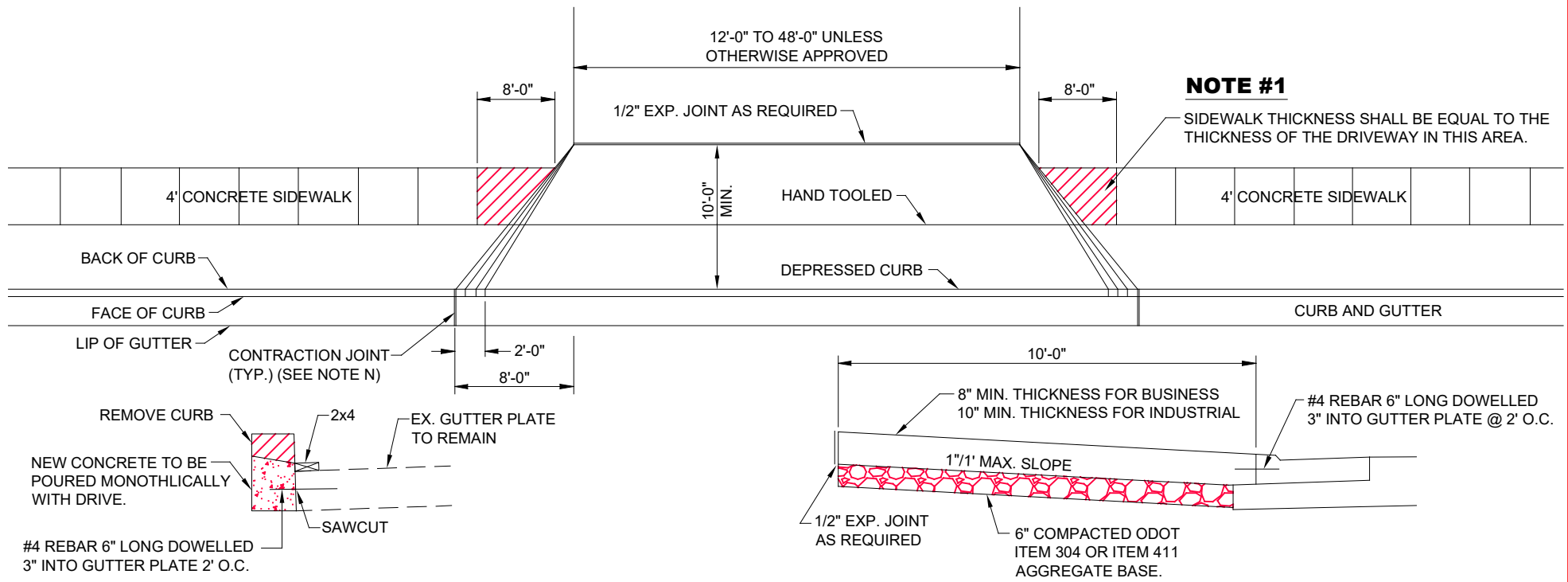

NOTE #1
SIDEWALK THICKNESS SHALL BE EQUAL TO THE THICKNESS OF THE DRIVEWAY IN THIS AREA.

NOTES

- A. DRIVE APPROACHES SHALL MEET THE REQUIREMENTS OF ODOT ITEM 452, AND 499 CAST IN PLACE CONCRETE
- B. DRIVE APPROACHES MAY BE PLACED MONOLITHICLY WITH CURB
- C. MAXIMUM JOINT SPACING SHALL BE 10' LONGITUDINALLY AND TRANSVERSELY WITH JOINTS AT TAPERS
- D. EXPANSION MATERIAL SHALL BE 1/2" PREMOLDED.
- E. 6" OF COMPACTED ODOT ITEM 304 OR ITEM 411 AGGREGATE BASE SHALL BE PLACED UNDER DRIVE APPROACHES.
- F. PROVIDE BROOM FINISH AND EDGING TO ALL EXPOSED SURFACES.
- G. WHERE CURB AND GUTTER HAS NOT BEEN DROPPED AT DRIVE APPROACHES, THE CONTRACTOR WILL CUT AND REMOVE CURB (SEE DETAIL)
- H. WHERE ASPHALTIC CONCRETE PAVEMENT IS DISTURBED, THE ASPHALT SHALL BE REPLACED BY THE CONTRACTOR AS DIRECTED BY THE CITY.
- I. JOINTS SHALL BE CLEANED AND EDGED BY A 1/4" RADIUS EDGER. LONGITUDINAL JOINTS SHALL BE AS DIRECTED BY THE CITY, EXPANSION JOINTS SHALL BE OF SUCH DIMENSIONS AS SHOWN ON STANDARD DRAWINGS FOR CONSTRUCTION JOINTS.
- J. MINIMUM WIDTH FOR ONE-WAY TRAFFIC IS 16'-0" MINIMUM WIDTH FOR TWO WAY TRAFFIC IS 25'-0" MAXIMUM WIDTH IS 36'-0" FOR BUSINESS AND 45'-0" FOR INDUSTRIAL UNLESS OTHERWISE APPROVED BY THE CITY.
- K. THIS STANDARD DRAWING IS FOR GUIDELINE PURPOSES, EACH INDIVIDUAL DRIVE WILL NEED TO BE DESIGNED AND SUBMITTED TO THE CITY FOR REVIEW AND APPROVAL.
- L. CONCRETE SHALL BE QC1 WITH 6% ± 2% OF THE TOTAL AIR. (4000 PSI, 600 LB/CY CEMENT. PROPORTIONING OPTIONS 1,2,&3 NOT ALLOWED.
- M. IF THE CURB IS REMOVED AND REPLACED DURING DRIVEWAY CONSTRUCTION, JOINTS BETWEEN CURB AND DRIVEWAY ARE TO BE DOWELED WITH #4 REBAR 6' IN LENGTH DOWELED 3" INTO THE GUTTER PLATE @ 2' OC.
- N. ALL NEW CONSTRUCTION OR MODIFICATIONS OF THE DRIVE APPROACHES REQUIRE A CONCRETE APPROACH REGARDLESS OF WHETHER THIS IS A SIDEWALK OR NOT. THE NEW APPROACH IS TO GO FROM EDGE OF EXISTING STREET TO THE RIGHT OF WAY OR A MINIMUM OF 10'-0"
- P. DRAINAGE ISSUES WILL HAVE TO BE ADDRESSED WHEN A DRIVEWAY IS INSTALLED OR MODIFIED.
- Q. PRECAUTIONS SHALL BE TAKEN TO PROTECT EXISTING CONCRETE, BRICK FROM TIRE MARKS AND DAMAGE DURING CONSTRUCTION.

COMMERCIAL AND INDUSTRIAL DRIVE APPROACH

CITY OF PIQUA



REVISIONS:	DATE APPROVED:
11-11-19 BG	DEC. 2016
04-27-20 BG	PAGE No.
	300-6

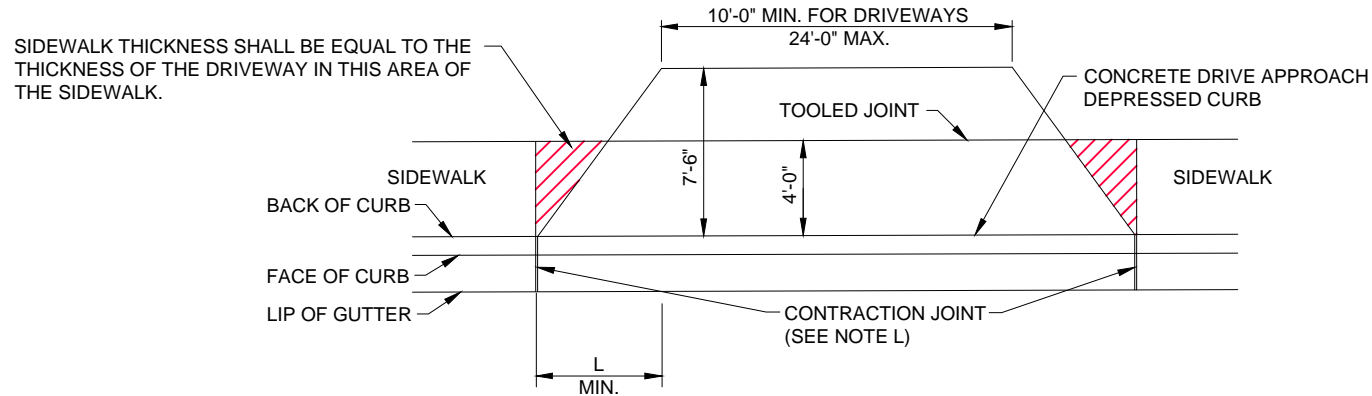
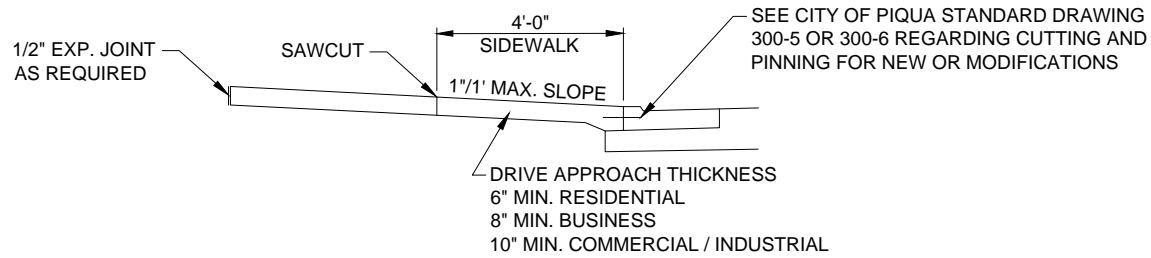

**DRIVE APRON WITH
NO CURB LAWN**

FOR DRIVEWAY SPECIFICATIONS
SEE PAGE 300-5 OR 300-6

NOTE #1

ALL CURB, DRIVEWAY OR SIDEWALK CONSTRUCTION
SHALL COMPLY WITH CITY OF PIQUA STANDARD
DRAWINGS 300-04, 300-05 AND 300-06

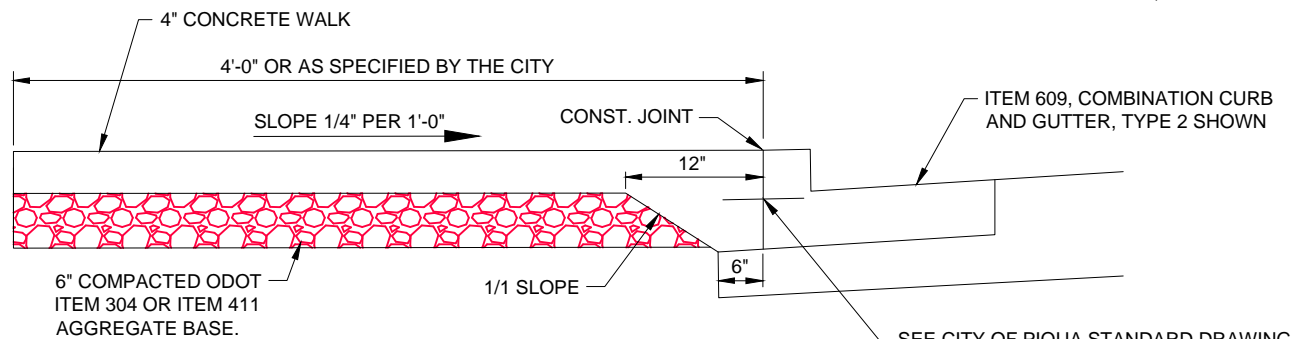

**CONCRETE SIDEWALK ABUTTING CURB,
COP TYPE #2 CURB SHOWN**

CITY OF PIQUA



**DRIVE APPROACH AND CONCRETE
SIDEWALK DETAIL WITH NO CURB LAWN**

REVISIONS:

DATE
APPROVED:
DEC. 2016

PAGE No.
300-7

BG

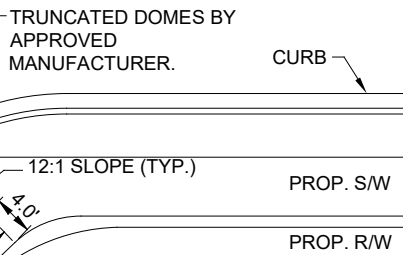
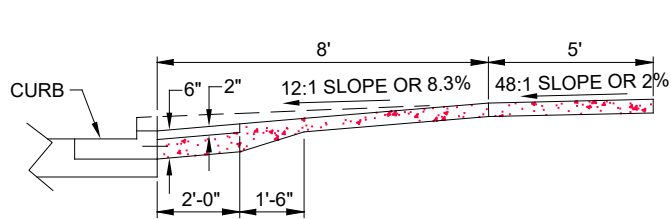

TYPE 1 RAMP DETAIL

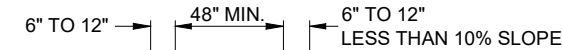

SECTION B-B

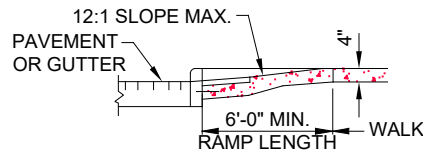

SECTION A-A

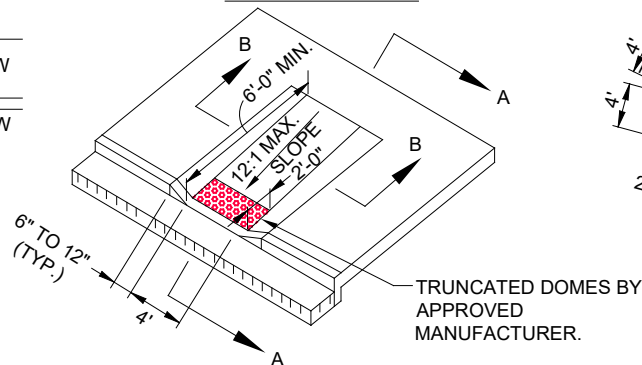

TYPE 2 RAMP DETAIL

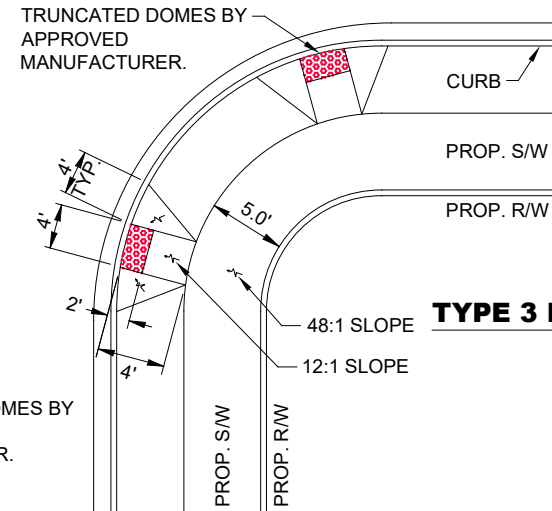
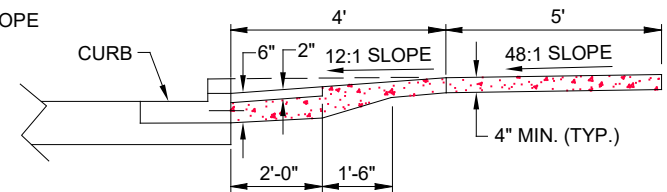

TYPE 3 RAMP DETAIL

NOTES

- A. CITY TO SPECIFY TYPE 1, 2, OR 3 RAMP.
- B. ANY COMBINATION OF SIDE SLOPES ON OPPOSITE SIDES OF A RAMP MAY BE USED TO BEST FIT THE SITE CONDITIONS.
- C. THE MINIMUM RAMP LENGTH IS 6'-0" FOR THE BACK OF A 6'-0" CURB AND MAY BE INCREASED WHERE FEASIBLE TO OBTAIN FLATTER RAMP SLOPE OR TO BETTER BLEND WITH THE WALK CONFIGURATION.
- D. WALK THICKNESS IN THE RAMP SLOPES SHALL BE 6" MINIMUM OR THICKER AS NECESSARY TO MATCH ADJACENT WALK THICKNESS.
- E. CURB RAMPS SHALL MEET AND BE FINISHED TO AMERICAN WITH DISABILITIES ACT (ADA) STANDARDS.
- F. TEXTURE OF CONCRETE SURFACES SHALL BE OBTAINED BY COURSE BROOMING TRAVERSE TO THE RAMP SLOPES AND SHALL BE ROUGHER THAN ADJACENT WALK.
- G. CURB RAMPS SHALL MEET THE REQUIREMENTS OF ODOT TEM 608 UNLESS OTHERWISE SPECIFIED WITHIN. REFER TO ODOT STANDARD DRAWINGS FOR ADDITIONAL CURB RAMP CONFIGURATIONS.
- H. CONCRETE SHALL BE ODOT QC1, (4000 PSI 520LB/CY CEMENT) PROPORTIONING OPTIONS 1, 2, & 3 NOT ALLOWED. CONCRETE SHALL CONTAIN 7% ± 2% TOTAL AIR.
- I. FOR RECONSTRUCTION JOBS THE CURB RAMPS WILL HAVE TO BE ADDRESSED BASED ON THE EXISTING CONDITIONS.
- J. TRUNCATED DOME SPECIFICATIONS; INSTALL DETECTABLE WARNINGS (TRUNCATED DOMES) FOR A DISTANCE OF 24" FROM THE BACK OF THE CURB FOR THE ENTIRE WIDTH OF THE RAMP OPENING WHERE IT IS FLUSH WITH THE PAVEMENT. THE TRUNCATED DOMES SHALL BE ODOT APPROVED, THE COLOR OF THE PANEL SHALL BE RED.
- K. CURB RAMPS TO BE POURED ON COMPACTED GRANULAR BEDDING. CITY INSPECTION OF FORM WORK IS REQUIRED PRIOR TO PLACING CONCRETE.
- L. PROVIDE BROOM FINISH AND EDGING TO ALL EXPOSED SURFACES. TEXTURE SHALL BE A MEDIUM BROOM WITH TOOL FINISH, CITY TO REVIEW AND APPROVE PRIOR TO POURING.
- M. ALL DETECTABLE WARNINGS CURB RAMPS TO BE CAST IRON MANUFACTURED BY EAST JORDAN IRON WORKS 7005 SERIES, NEEHAH FOUNDRY MODEL R-4984.
- N. ALL RAMPS SHALL BE DOWELLED TO THE CURB BY THE USE OF #4 REBAR AS PER CITY STANDARDS 300-07 CONCRETE SIDEWALK ABUTTING TYPE 2 CURB DETAIL.
- O. ADA SPECIFICATIONS SHALL ALL INCLUDE ALL PUBLIC RIGHT OF WAY ACCESSIBILITY GUIDELINES (PROWAG) FEDERAL STANDARDS.

CITY OF PIQUA



CURB RAMPS

REVISIONS:
9-28-16 BG
11-11-19 BG
12-31-20 BG/KK

DATE APPROVED:
DEC. 2016

PAGE No.
300-8

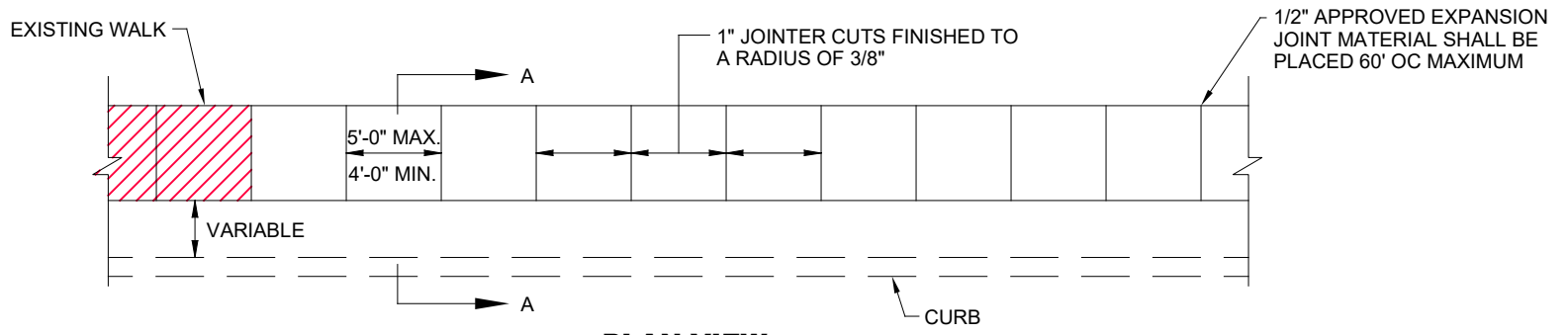

PLAN VIEW

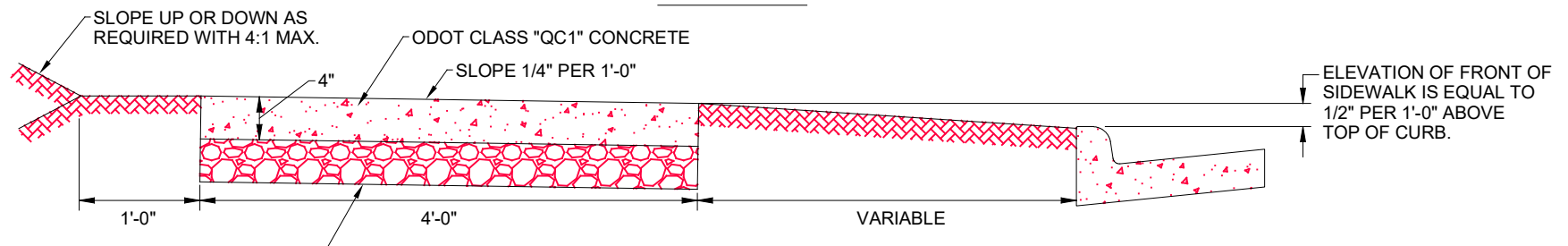

SECTION A-A

4" OF COMPACTED ODOT ITEM 304 OR ITEM 411 AGGREGATE BASE SHALL BE PLACED ON COMPACTED SUBGRADE UNDER ALL SIDEWALK AND CURB RAMPS.

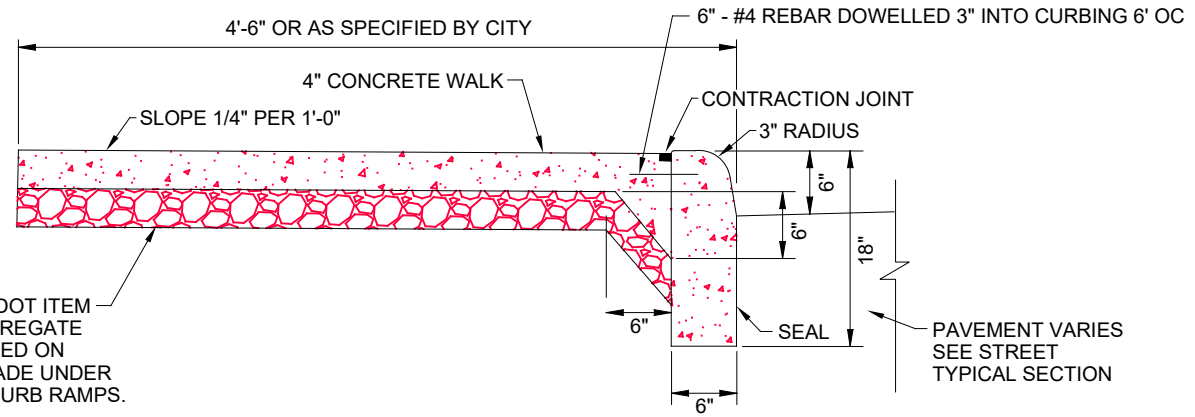

COMBINED CURB AND SIDEWALK DETAIL

CITY OF PIQUA



CONCRETE SIDEWALK DETAIL

REVISIONS:
12-31-20 BG/KK

DATE APPROVED:
DEC. 2016

PAGE No.
300-9

NOTES

- A. WALK TO BE POURED ON COMPACTED GRANULAR BEDDING.
- B. PROVIDE BROOM FINISH TO ALL EXPOSED SURFACES.
- C. CONCRETE SHALL CONFORM TO ODOT ITEM 499 CONCRETE. CONCRETE WORK SHALL CONFORM TO ODOT ITEM 499 UNLESS OTHERWISE SPECIFIED WITHIN.
- D. PROVIDE EDGING AROUND ALL EXPOSED SURFACES.
- E. APPLY ONE COAT OF A WHITE PIGMENTED ODOT APPROVED CONCRETE SEALER ON ALL SURFACES ACCORDING TO MANUFACTURER'S RECOMMENDATIONS.
- F. WHEN RENOVATING EXISTING STREETS, THE SIDEWALKS SHALL BE REPLACED TO CONFORM WITH CITY CONSTRUCTION STANDARDS AND DRAWINGS.
- G. CONCRETE SHALL BE ODOT QC1, (4000 PSA, 520 LB/CY CEMENT) PROPORTIONING OPTIONS 1,2, & 3 NOT ALLOWED.
- H. CONCRETE SHALL CONTAIN 7% ± 2% OF TOTAL AIR.
- I. PROPERTY PINS SHALL BE RE-ESTABLISHED AFTER FINISHING OF SIDEWALK.
- J. COLD WEATHER POURING WILL NOT BE PERMITTED IF AMBIENT AIR TEMPERATURE IS AT OR BELOW 32°F FOR THE NEXT 72 HOURS AFTER THE PROPOSED POUR DATE. ALL COLD TEMPERATURE POURS ARE TO BE BLANKETED FOR A PERIOD OF NO LESS THAN THREE DAYS FROM THE TIME OF THE POUR. AT NO TIME SHALL THERE BE ANY FROST ON ANY PART OF THE GRAVEL BASE, THE FORMS OR ANY ADJURING MEMBER PRIOR TO POURING THE CONCRETE.

SIDEWALK JOINTS

- 1. GENERAL: CONSTRUCT ISOLATION, CONSTRUCTION, AND CONTRACTION JOINTS, AND TOOL EDGINGS TRUE TO LINE WITH FACES PERPENDICULAR TO SURFACE PLANE OF CONCRETE. CONSTRUCT TRANSVERSE JOINTS AT RIGHT ANGLES TO CENTERLINE, UNLESS OTHERWISE INDICATED.
 - A. WHEN JOINING EXISTING PAVEMENT, PLACE TRANSVERSE JOINTS TO ALIGN WITH PREVIOUSLY PLACED JOINTS, UNLESS OTHERWISE INDICATED.
- 2. CONSTRUCTION JOINTS: SET CONSTRUCTION JOINTS AT SIDE AND END TERMINATION OF PAVEMENT AND AT LOCATIONS WHERE PAVEMENT OPERATIONS ARE STOPPED FOR MORE THAN ONE-HALF HOUR, UNLESS PAVEMENT TERMINATES AT ISOLATION JOINTS.
- 3. EXPANSION JOINTS: FORM ISOLATION JOINTS OF PREFORMED JOINT-FILLER STRIPS ABUTTING MANHOLES, STRUCTURES, WALKS, OTHER FIXED OBJECTS, AND WHERE INDICATED. EXPANSION JOINTS SHALL NOT BE PLACED AT THE BUILDING FACE UNLESS DIRECTED BY THE CITY OF PIQUA.
 - A. LOCATION OF EXPANSION JOINTS AT INTERVALS OF 60', UNLESS OTHERWISE INDICATED.
 - B. LOCATE EXPANSION JOINTS ALONG BUILDINGS.
 - C. THE EXPANSION JOINT MATERIAL SHALL BE ½" THICK ODOT SPECIFICATIONS.
- 4. CONTRACTION JOINTS: FORM WEAKENED-PLANE CONTRACTION JOINTS, SECTIONING CONCRETE INTO AREAS AS INDICATED IN THE PLANS. CONSTRUCT CONTRACTION JOINTS FOR A DEPTH EQUAL TO AT LEAST ONE-FOURTH OF THE CONCRETE THICKNESS, WHERE INDICATED, AS FOLLOWS:
 - A. GROOVED JOINTS: FROM CONTRACTION JOINTS AFTER INITIAL FLOATING BY GROOVING AND FINISHING EACH EDGE OF JOINT WITH GROOVER TOOL TO THE FOLLOWING RADIUS. REPEAT GROOVING OF CONTRACTION JOINTS AFTER APPLYING SURFACE FINISHES. ELIMINATE GROOVER OVERFLOW SLURRY MARKS ON CONCRETE SURFACES. QUALITY WORK SHALL BE PERFORMED OR THE NEW SIDEWALK WILL BE REMOVED AND REDONE AT THE CONTRACTOR'S EXPENSE. RADIUS TO BE ¼ INCH (6 MM).
 - B. SAWED JOINTS WILL NOT BE PERMITTED.
- 5. EDGING: TOOL EDGES OF JOINTS IN CONCRETE AFTER INITIAL FLOATING WITH AN EDGING TOOL TO A RADIUS OF 1/4 INCH (6MM). REPEAT TOOLING OF EDGES AFTER APPLYING SURFACE FINISHES. ELIMINATE TOOL MARKS (OVERFLOW SLURRY) ON CONCRETE SURFACES.

CITY OF PIQUA



CONCRETE SIDEWALK NOTES

REVISIONS:
 09-28-16 BG
 11-11-19 BG
 12-31-20 BG/KK
 02-03-21 BG/KK

DATE APPROVED:
 DEC. 2016

PAGE No.
300-10

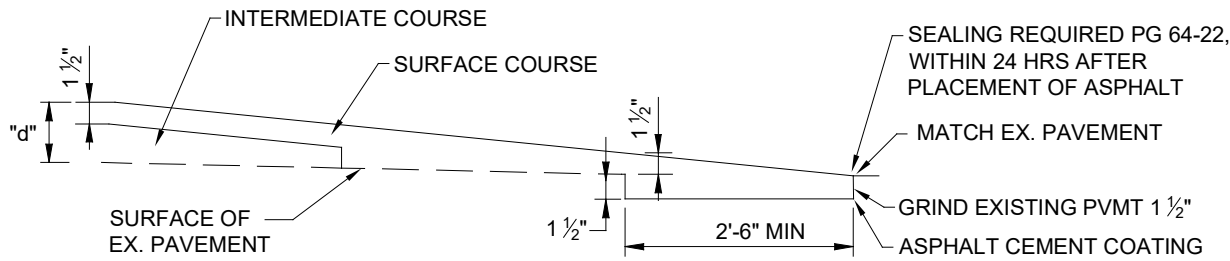

NOTE: MINIMUM LENGTH = 10' PER INCH OF "d".

BUTT JOINT DETAIL

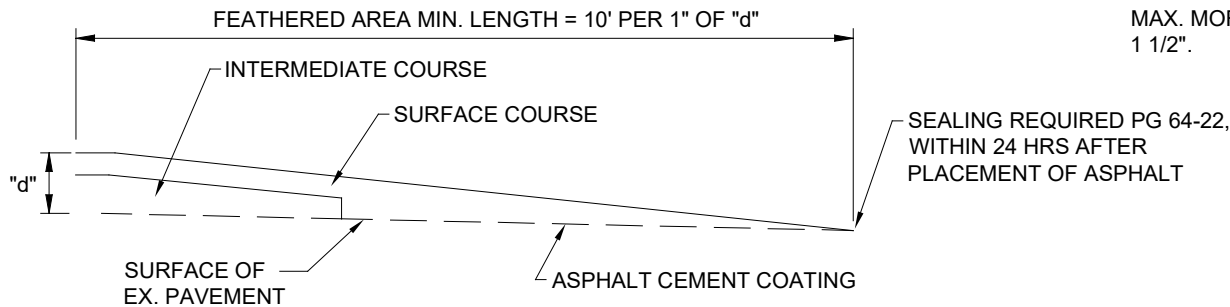

FEATHERING DETAIL

NOTES

METAL ONE PIECE ADJUSTING RINGS SHALL:

- A. ATTACH SECURELY TO THE EXISTING FRAME BY TACK WELD OR MECHANICAL DEVICES.
- B. CONSIST EITHER OF CAST METAL HAVING AN INTEGRAL RIM AND SEAT, OR BE FABRICATED METAL WITH A STURDY CONNECTION BETWEEN THE SEAT AND RIM.
- C. PROVIDE AN EVEN SEAT FOR THE MANHOLE COVER.
- D. SHALL BE A SOLID ONE PIECE RING ACCEPTABLE TO THE CITY OF PIQUA. **ADJUSTABLE DIAMETER MANHOLE RINGS WILL NOT BE ACCEPTABLE.**
- E. ANY INSTALLATION UNACCEPTABLE TO THE CITY SHALL BE REPLACED BY THE CONTRACTOR AT THEIR EXPENSE.
- F. MONUMENT BOXES SHALL MEET THE REQUIREMENTS OF ODOT ITEM 623 UNLESS OTHERWISE SPECIFIED WITHIN.

MANHOLES ADJUSTED TO GRADE FOR OVERLAYS

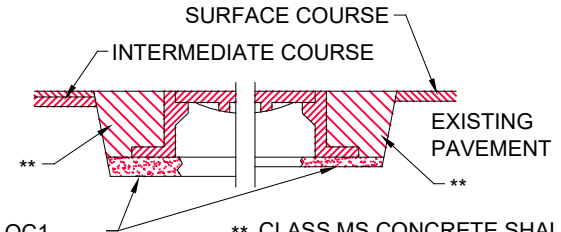

GRADE RINGS, QC1 CONCRETE OR MORTAR, MAX. MORTAR THICKNESS 1 1/2".

** CLASS MS CONCRETE SHALL BE PLACED A MIN. OF 3" BEYOND THE BASE OF THE CASTING. THE WIDTH AT THE TOP SHALL BE ADJUSTED TO CONFORM TO THE MIN. BASE DIAMETER.

USING CONCRETE OR MORTAR

PROVIDE METAL ONE PIECE ADJUSTING RINGS

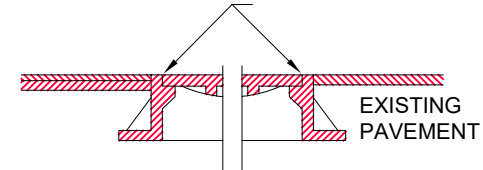

METAL ONE PIECE ADJUSTING RINGS

GENERAL

- A. ALL STREET CONSTRUCTION SHALL BE IN ACCORDANCE WITH ODOT SPECIFICATIONS LATEST REVISION.
- B. CONTRACTOR MUST APPLY FOR NECESSARY PERMITS, FEES WITH THE CITY BEFORE CONSTRUCTION OR DEMOLITION BEGINS.

PAVEMENT REPLACEMENT

- A. IMMEDIATELY AFTER PLACEMENT OF BACKFILL IN EXISTING STREETS, A TEMPORARY PAVEMENT SHALL BE INSTALLED AND THE STREET OPENED. TEMPORARY PAVEMENT SHALL CONSIST OF 8" OF COMPACTED ODOT SPECIFIED 411 BASE AND A SURFACE COURSE APPROVED BY THE CITY. THE SURFACE COURSE KEPT FLUSH WITH THE EXISTING STREET.
- B. PERMANENT PAVEMENT REPLACEMENT SHALL BE EQUAL TO OR EXCEED THE EXISTING PAVEMENT (MINIMUM PAVEMENT COMPOSITION, SEE PAGE 300-2).
- C. ANY SETTLEMENT OF A TRENCH CAUSING A DEPRESSION SHALL BE REFILLED AS REQUIRED AT THE CONTRACTOR'S EXPENSE. THIS PROVISION APPLIES FOR ONE YEAR PERIOD AFTER THE WORK HAS BEEN ACCEPTED BY THE CITY.
- D. ALL TEMPORARY PAVEMENT AND SIDEWALK SHALL BE MAINTAINED BY THE CONTRACTOR OR DEVELOPER AT THEIR OWN EXPENSE IN A SUITABLE AND SAFE CONDITION FOR TRAFFIC UNTIL PERMANENT REPLACEMENT IS MADE OR THE PROJECT IS FINALLY ACCEPTED BY THE CITY. COLD PATCH ALL TRENCHES A MINIMUM OF 4" WHEN FINAL ASPHALT WILL NOT BE REPLACED WITHIN 24 HOURS.

TRAFFIC CONTROL

- A. THE CONTRACTOR SHALL MAINTAIN TRAFFIC CONTROL AT ALL TIMES WITH THE PROPER BARRICADES AS PER THE OHIO MANUAL OF UNIFORM TRAFFIC CONTROL DEVICES. THESE CONTROL DEVICES SHALL BE IN PLACE PRIOR TO ANY WORK COMMENCING.
- B. TRAFFIC SHALL BE MAINTAINED AT ALL TIMES UNLESS OTHERWISE APPROVED BY THE CITY.

CURB STAKING AND ROADWAY

- A. LINE AND GRADE EVERY 25'-0" ON A CONVENIENT OFFSET.

PAVEMENT (ASPHALT)

- A. THE CONTRACTOR SHALL PROVIDE THE CITY WITH A COPY OF THE NORMAL (MEDIUM TRAFFIC) ODOT 448 JOB MIX FORMULA FOR EACH PLANT THAT PROVIDES HOT MIXED ASPHALT TO THIS PROJECT. ALL MIXES SHALL FOLLOW ODOT JOB MIX FORMULA.
- B. ALL WORK SHALL ADHERE TO ODOT'S LATEST REVISIONS AND TO THE CITY SPECIFICATIONS WHICHEVER IS MORE STRINGENT SHALL PREVAIL UNLESS OTHERWISE APPROVED.
- C. PATCHED AREAS SHALL BE SEALED ON THE PERIMETER OF THE PATCH WITH ASPHALT CEMENT.
- D. ALL UTILITY ADJUSTMENTS, MANHOLE, WATER VALVES, SHALL BE RAISED TO FINISHED GRADE AFTER THE FINAL ASPHALT COURSE IS LAID. IF SMOOTHNESS DOESN'T MEET THE CITY'S REQUIREMENTS A REPAIR SIMILAR TO MR. MANHOLE SHALL BE USED TO ADJUST THE MANHOLE OR VALVE.
- E. ASPHALT CEMENT SHALL BE USED NEXT TO THE LIP OF GUTTER PRIOR TO THE FINAL ASPHALT LIFT BEING PLACED (PG64-22 SEAL).

- F. TACK COAT SHALL BE APPLIED PRIOR TO THE PLACEMENT OF THE FINAL LIFT OF ASPHALT IF THE EXISTING ASPHALT LIFT IS DIRTY, OR AFTER TEN DAYS UNLESS OTHERWISE APPROVED. TEMPERATURE MUST BE 50° F OR HIGHER, ALL TACK SHALL BE TRACKLESS.
- G. PRIME COAT SHALL BE APPLIED ON NEW AGGREGATE WHEN TEMPERATURE IS 50° F OR HIGHER. ALL DRIVEWAYS SHALL BE PRIMED PRIOR TO PLACEMENT OF ASPHALT UNLESS OTHERWISE APPROVED.
- H. NO ASPHALT SHALL BE PLACED OVER EXCAVATED TRENCHES UNTIL IT HAS BEEN COMPACTED AS PER CITY SPECIFICATIONS.
- I. FINAL LIFT OF ASPHALT SHALL BE FINISHED TO 1/4" ABOVE THE LIP OF GUTTER.
- J. ASPHALT CEMENT SHALL BE USED ON ALL JOINTS AND FEATHERED SURFACES PRIOR TO PLACEMENT OF THE NEXT COURSE OF ASPHALT TO THE ABUTTING JOINT, UNLESS OTHERWISE APPROVED.
- K. ALL EDGES TO BE TRIMMED BACK TO SOLID MATERIAL BY SAWING AND BE STRAIGHT AND NEAT AS PER THE CITY'S INSTRUCTIONS.

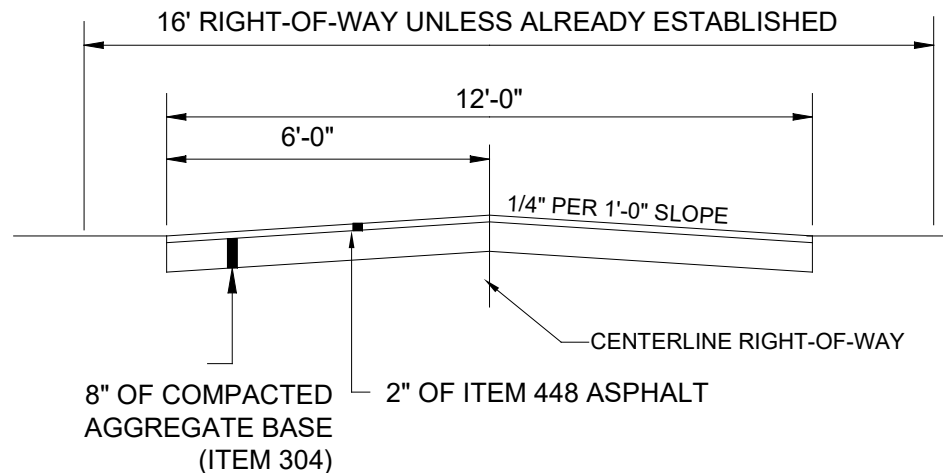

TYPICAL ALLEY CONSTRUCTION

- A. MINIMUM STANDARD (UNLESS OTHERWISE APPROVED).
- B. FOR RENOVATION OF EXISTING ALLEYS ONLY. NO NEW ALLEYS WILL BE APPROVED WITHIN THE CITY.

PERMIT REQUIRED

A RIGHT-OF-WAY PERMIT FOR ANY DIGGING OR EXCAVATING WITHIN A PUBLIC RIGHT-OF-WAY FOR ANY STREET OR ALLEY IS REQUIRED 48 HOURS IN ADVANCE OF THE WORK. IN THE EVENT OF AN EMERGENCY, THE PERMIT APPROVAL REQUIREMENT SHALL BE WAIVED AND THE PROPER APPLICATION MUST BE SUBMITTED AS SOON AS POSSIBLE, BUT NO LATER THAN THE END OF THE FIRST WORKING WEEKDAY AFTER THE START OF WORK. AN EMERGENCY IS DEFINED AS A REPAIR REQUIRED TO PROVIDE SERVICE TO UTILITY CUSTOMERS OR TO MITIGATE A HAZARD, WHICH THREATENS PUBLIC HEALTH OR SAFETY.

PERMIT FORMS ARE AVAILABLE FROM THE CITY STREET DEPARTMENT. THE PERMIT FORM IS TO BE COMPLETED BY THE PERSON OR FIRM PLANNING THE WORK WITHIN THE RIGHT-OF-WAY. ALL FEES MUST BE PAID AND APPROVALS OBTAINED BEFORE ANY WORK IS STARTED. A 72 WORKING HOUR LEAD-TIME IS RECOMMENDED. A PERMIT FEE OF \$25 WILL BE REQUIRED OF EACH APPLICANT, INCLUDING CITY DEPARTMENTS.

PERFORMANCE BOND

ANY INDIVIDUAL OR FIRM WHO MAKES APPLICATION FOR A RIGHT-OF-WAY OPENING PERMIT MUST PROVIDE A CURRENT PERFORMANCE BOND TO THE CITY OF PIQUA IN THE AMOUNT OF \$3000.

NO BOND IS REQUIRED FOR PLUMBERS WHO HOLD A CURRENT PLUMBING LICENSE IN THE CITY OF PIQUA AND HAVE A CURRENT PERFORMANCE BOND ON FILE IN THE HEALTH DEPARTMENT.

IN THE EVENT THAT AFTER NOTIFICATION FROM THE CITY ANY CONTRACTOR FAILS TO CORRECT PROBLEMS ASSOCIATED WITH POOR TRENCH REPAIR OR MAINTENANCE WITHIN 24 HOURS OF NOTIFICATION, THE CITY RESERVES EXCLUSIVE RIGHT TO CORRECT THE PROBLEMS AND COLLECT ASSOCIATED COSTS FROM THE PERFORMANCE BOND.

WORK REQUIREMENTS

THE APPLICANT SHALL HAVE SUFFICIENT BARRICADES, WARNING SIGNS, AND LIGHTS DURING THE ENTIRE PERIOD THAT WORK IS BEING PERFORMED AND SHALL ADHERE TO APPLICABLE SECTION OF THE OHIO MANUAL OF UNIFORM TRAFFIC CONTROL DEVICES.

ALL DISTURBED AREAS MUST BE RETURNED TO A CONDITION THAT IS AS GOOD AS OR BETTER THAN THE CONDITION BEFORE THE WORK BEGAN. ALL REPAIRS MUST MEET CITY SPECIFICATIONS. THE CITY STREET SUPERINTENDENT WILL INSPECT AND APPROVE ALL REPAIRS. THE BOND WILL BE RETURNED AFTER ALL REPAIRS ARE APPROVED, IF APPLICABLE. FOR CLOSURE OF ARTERIALS OR BUSY COLLECTORS THE CITY RESERVES THE RIGHT TO DIRECT CONTRACTOR TO CLOSE THE STREET DURING OFF PEAK TRAFFIC HOURS. CLOSURE MAY OCCUR AT NIGHT OR ON WEEKENDS. CONTRACTOR SHALL PROVIDE ALL TRAFFIC CONTROL ASSOCIATED WITH ROAD CLOSURE. EFFORTS SHALL BE MADE TO MINIMIZE ANY DISTURBANCE TO TREES OR ROOTS. EXCAVATION CAUSING DAMAGE TO TREES WILL RESULT IN REMOVAL AND REPLACEMENT. IF A TREE IS CUT, IT MAY RESULT IN PROPERTY DAMAGE TO THE PROPERTY OWNER, THIS IS THE DECISION OF THE CITY ENGINEER.

THE APPLICANT MUST NOTIFY ALL AFFECTED PROPERTY OWNERS IN WRITING, AND PROVIDE A COPY OF THE NOTIFICATION AND MAILING LIST PRIOR TO THE ENGINEERING DEPARTMENT ISSUING THE PERMIT.

ALL CONTRACTORS WHO PERFORM WORK REQUIRING ENTRY INTO ANY CONFINED SPACE OF A CITY-OWNED UTILITY SHALL COMPLY WITH THE CITY'S CONFINED SPACE ENTRY PROCEDURES AND IN ACCORDANCE WITH ALL OSHA REGULATIONS, IF APPLICABLE, AND APPROVAL FROM THE WASTEWATER SUPERINTENDENT OR DESIGNEE.

MATERIAL SPECIFICATION

ALL WORK SHALL BE IN ACCORDANCE WITH THE ATTACHED DRAWINGS AND SPECIFICATIONS AND APPROVED BY THE ENGINEERING DEPARTMENT PRIOR TO COMMENCEMENT OF WORK.

STREET OPENINGS- THE MATERIAL USED TO FILL IN A DITCH OR A HOLE SHALL BE GRANULAR MATERIAL (#304,#411) OR ODOT ITEM 613 LOW STRENGTH MORTAR BACKFILL. OTHER APPROVED GRANULAR MATERIALS MAY BE USED ONLY UPON THE CONTRACTOR RECEIVING PRIOR WRITTEN APPROVAL FROM THE ENGINEERING DEPARTMENT IF EXTENUATING CIRCUMSTANCES EXIST. CONTRACTORS CONCERNED WITH THE CONTACT OF THE LOW STRENGTH MORTAR BACKFILL WITH THE FITTINGS AND THE PIPE MAY PLACE A MAXIMUM OF 12 INCHES OF GRANULAR BACKFILL ABOVE THE TOP OF THE PIPE.

FOR RIGHT-OF-WAY OPENINGS BEYOND THE LIMITS OF THE PAVEMENT THE BACKFILL SHALL BE IN ACCORDANCE WITH 300-14 (2) BACKFILL.

ASPHALT SURFACE- ASPHALT SURFACE SHALL BE PLACED TO A DEPTH AS STATED IN 300-14 (3) PAVEMENT RESTORATION.

CONSTRUCTION

REPAIR AREAS SHALL BE RECTANGULAR IN SHAPE WITH DIMENSIONS AS REQUIRED TO ENVELOP THE SURFACE DETERIORATION. AT THE DIRECTION OF THE CITY THE LIMITS OF THE REPAIRED REPLACEMENT MAY BE EXTENDED AS DEEMED NECESSARY. PAVEMENT SHALL BE REMOVED BY METHODS THAT WILL NOT DAMAGE ADJACENT PAVEMENT.

ALL JOINTS AND VERTICAL FACES SHALL BE SAW CUT, CLEANED AND COATED WITH BITUMINOUS MATERIAL (TACK COAT) PRIOR TO PLACEMENT OF BITUMINOUS CONCRETE.

ALL JOINTS SHALL BE SEALED WITH ASPHALT SEALER AFTER THE FINAL SURFACE MATERIAL IS PLACED.

IF LOW STRENGTH MORTAR BACKFILL IS USED, LOW STRENGTH MOTAR BACKFILL SHALL BE BROUGHT UP UNIFORMLY TO THE FILL LINE SHOWN ON THE PLANS OR THE BOTTOM OF THE EXISTING PAVEMENT.

CITY OF PIQUA



**STREET CUT AND RIGHT-OF-WAY OPENING
STANDARD DRAWINGS AND SPECIFICATIONS**

REVISIONS:
12-9-16 BG
12-31-20 BG/KK

DATE
APPROVED:
DEC. 2016

PAGE No.
300-13

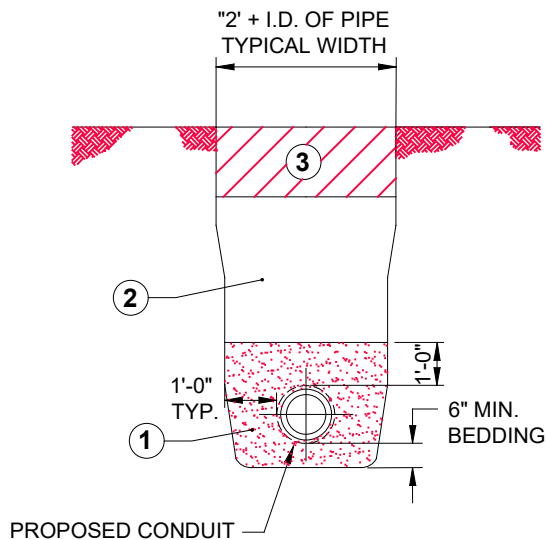

TRENCH DETAIL

- GRANULAR MATERIAL SHALL BE PLACED IN MAXIMUM 8-INCH LIFTS. FOR GRANULAR EMBANKMENT AND STRUCTURAL BACKFILL, COMPACT EACH LIFT OF MATERIAL USING MECHANICAL DEVICES, HOE RAMS, JUMPING JACKS, HAND DEVICES, VIBRATING PLATES, OR OTHER SIMILAR EQUIPMENT. COMPACTION REQUIREMENTS SHALL BE 98% OF STANDARD PROCTOR CURVE.
- LOW STRENGTH MORTAR BACKFILL SHALL BE FURNISHED AND PLACED AS PER ODOT ITEM 613.

ALL TRENCH EDGES NOT WITHIN THE STREET RIGHT-OF-WAY, NOT UNDER OR WITHIN 5 FEET OF PROPOSED OR EXISTING PAVEMENT, CURB, DRIVEWAYS, ALLEYS, OR WALKS CAN BE BACKFILLED WITH CLEAN NATIVE MATERIAL COMPACTED IN 12 INCH LIFTS. MATERIAL SHALL BE COMPACTED TO 85% OF THE ORIGINAL COMPACTION. NO MATERIAL SHALL BE USED FOR BACKFILLING THAT CONTAINS GRANULAR MATERIAL ROCK OR STONE GREATER THAN 4 INCHES IN DIAMETER.

CONCRETE RESTORATION

ALL CONCRETE DRIVEWAYS, DRIVE APPROACHES, AND SIDEWALKS WITHIN THE STREET RIGHT-OF-WAY, SHALL BE REPLACED WITH ODOT CLASS QC1 OR QCMS CONCRETE FOR THE FOLLOWING:

- SIDEWALKS - MINIMUM THICKNESS OF 4 INCHES OF CONCRETE.
- MATCH ORIGINAL WIDTH OF SIDEWALK
- MINIMUM WIDTH OF 4 FEET REQUIRED
- MINIMUM THICKNESS OF 4 INCHES
- DRIVEWAYS AND DRIVE APPROACHES
- RESIDENTIAL: MINIMUM THICKNESS OF 6 INCHES OF CONCRETE
- BUSINESS: MINIMUM THICKNESS OF 8 INCHES OF CONCRETE
- INDUSTRIAL: MINIMUM OF THICKNESS 10 INCHES OF CONCRETE

ALL CONCRETE DRIVEWAYS, DRIVE APPROACHES, AND SIDEWALKS OUTSIDE OF THE STREET RIGHT-OF-WAY SHALL BE REPLACED EQUAL TO THE EXISTING MATERIAL COMPOSITION.

1 BEDDING

GRANULAR BEDDING MATERIAL SHALL BE CRUSHED STONE OR GRAVEL COMPLYING WITH TYPE 2 BEDDING (#57 OR #67). BEDDING SHALL EXTEND 6 INCHES BELOW THE CONDUIT. BEDDING MATERIAL SHALL EXTEND 12 INCHES ABOVE THE TOP AND TO EACH SIDE OF THE CONDUIT. USE SHOVEL SLICING AND SPUD BARS IN CONJUNCTION WITH THE COMPACTION OPERATIONS TO COMPACT THE MATERIAL AND TO MANIPULATE THE MATERIAL UNDER THE HAUNCH OF THE PIPE.

2 BACKFILL

ALL TRENCH EDGES WITHIN THE STREET RIGHT-OF-WAY, UNDER OR WITHIN 5 FEET OF PROPOSED OR EXISTING PAVEMENT, CURB, DRIVEWAYS ALLEYS, OR WALKS SHALL BE BACKFILLED WITH EITHER GRANULAR BACKFILL MATERIAL (#304, #411) OR ODOT ITEM 613 LOW STRENGTH MORTAR BACKFILL.

3 PAVEMENT RESTORATION

IN PAVED AREAS WITHIN THE STREET RIGHT-OF-WAY THE PAVEMENT AND AGGREGATE BASE COMPOSITION SHALL BE PROVIDED EQUAL TO THE EXISTING PAVEMENT BUT IN NO CASE SHALL THE COMPOSITION BE LESS THAN THE FOLLOWING: 1-½ INCHES OF ODOT ITEM 448, SURFACE COURSE, TYPE 1; 2-1/2 INCHES OF ODOT ITEM 448 INTERMEDIATE COURSE, TYPE 2; 10 INCHES OF ODOT ITEM 304 AGGREGATE BASE.

IN ALLEYS AND DRIVEWAYS OUTSIDE OF THE STREET RIGHT-OF-WAY, THE REPLACEMENT OF PAVEMENT AND/OR AGGREGATE SHALL BE EQUAL TO THE EXISTING ALLEYWAY OR DRIVEWAY COMPOSITION. IF THE PERMANENT ASPHALT CANNOT BE APPLIED WITHIN 48 HOURS OF THE INITIAL REPAIR, COLD PATCH SHALL BE APPLIED TO THE TRENCH SURFACE. MINIMUM THICKNESS OF THE COLD PATCH MATERIAL SHALL BE 4 INCHES. SAID MATERIAL SHALL BE REMOVED PRIOR TO THE PLACEMENT OF ODOT ITEM 448.

COMPACTION GUIDELINES

THE CONTRACTOR MAY OPERATE SMALL COMPACTION EQUIPMENT WITH LESS THAN A TOTAL WEIGHT OF 1 TON OVER THE CONDUIT TO COMPACT THE BACKFILL. DO NOT USE HOE RAMS ON TOP OF THE CONDUIT UNTIL 2 FEET OF BACKFILL IS COMPACTED ON TOP OF THE CONDUIT. THE CONTRACTOR MAY OPERATE COMPACTION EQUIPMENT WITH LESS THAN A TOTAL WEIGHT OF 8 TONS, BUT MORE THAN 1 TON, OVER THE CONDUIT AFTER PLACING AND COMPACTING 2 FEET OF BACKFILL. DO NOT OPERATE EQUIPMENT WITH A TOTAL WEIGHT OF 8 TONS OR MORE UNTIL PLACING AND COMPACTING A COVER OF 4 FEET OVER THE TOP OF THE CONDUIT. THE ABOVE RESTRICTIONS APPLY WHEN WORKING WITHIN ONE SPAN ON EACH SIDE OF THE CONDUIT, OR 6 FEET, WHICHEVER IS LESS.

ALL TRENCHES AND EXCAVATION SHALL BE BACKFILLED IMMEDIATELY AFTER THE PLACEMENT OF THE CONDUIT. UNLESS DIRECTED OTHERWISE BY THE CITY ENGINEER. UNDER NO CIRCUMSTANCES SHALL WATER BE PERMITTED TO RISE IN UNBACKFILLED TRENCHES AFTER THE CONDUIT HAS BEEN PLACED.

AGGREGATE BASE, ASPHALT, CONCRETE AND SUBGRADE TESTING

AN INDEPENDENT CERTIFIED TESTING LABORATORY ACCEPTANCE TO THE CITY OF PIQUA IS TO BE USED BY THE CONTRACTOR TO PERFORM THE REQUIRED TESTING. THE TESTING LAB SHALL PROVIDE THE CITY OF PIQUA WITH ONE COPY OF ALL TEST RESULTS, INSPECTION LOGS ETC.

- 1) ASPHALT- ONE TEST SAMPLE PER TYPE PER PAVED LAYER OR PAVER PASS PER DAY PLANT TESTING, BY ODOT, OR BY A TESTING LAB
 - A) TEST- GRADATION AND EXTRACTION TO DETERMINE BITUMEN CONTENT BASED ON SUBMITTED JOB MIX FORMULA.
 - B) THE ENGINEER MY REQUIRE ADDITIONAL ASPHALT SAMPLES BY TYPE, PER LAYER OR PAVER PASS.
- PAVED
- 2) CONCRETE
 - A) CURBING- ONCE DAILY DURING PLACEMENT
 - B) DRIVEWAY- ONCE DAILY DURING PLACEMENT
 - C) SIDEWALK- ONCE DAILY DURING PLACEMENT
 - D) TESTING REQUIRED
 - I) SLUMP TEST
 - II) AIR ENTRAINMENT
 - III) CONCRETE TEST CYLINDERS FOR COMPRESSION STRENGTH TESTING AT 7 DAYS, 14 DAYS, AND 28 DAYS.
 - E) THE ENGINEER MAY REQUIRE ADDITIONAL SAMPLES OF CONCRETE FOR CURB, DRIVEWAY OR SIDEWALK.
- 3) AGGREGATE BASE AND STREET SUB-GRADE
- 4)
 - A) STREET SUB-GRADE
 - I) COMPACTION/ DENSITY TESTING USING "ONE POINT" PROCTOR" AT 98%
 - II) A MAXIMUM OF 100-FOOT INTERVALS OUTSIDE OF ALL UTILITY TRENCHES IN UNDISTURBED SOILS, ALTERNATING SIDES OF THE STREET.

- i) A MINIMUM OF 20 FEET FROM START AND END OF WORK AREA.
 - ii) A MINIMUM OF 3 FEET FROM THE PROPOSED CURB-LINE.
 - B) AGGREGATE BASE
 - I) COMPACTION/DENSITY TESTING USING STANDARD MATERIAL PROCTOR AT 98%
 - II) A MINIMUM OF 20 FEET FROM START AND END OF WORK AREA.
 - III) A MAXIMUM OF 100-FOOT INTERVALS ALTERNATING SIDES OF THE STREET.
 - IV) A MINIMUM OF 3 FEET FROM THE PROPOSED CURB-LINE.
 - C) THE ENGINEER MAY REQUIRE ADDITIONAL COMPACTION / DENSITY TESTING IN INTERSECTIONS, FILL AREAS OR IN AREAS OF UNDERCUTTING.
- 4) DRIVEWAYS AND SIDEWALK AREAS WHERE EMBANKMENT HAS BEEN PLACED OR UNDERCUTTING HAS OCCURRED AT THE DISCRETION OF THE ENGINEER.
 - A) COMPACTION / DENSITY TESTING USING STANDARD MATERIAL PROCTOR AT 98%
 - B) SIDEWALKS, AS DIRECTED
 - I) A MINIMUM OF 10 FEET FROM THE START AND END OF THE WORK AREA.
 - II) A MAXIMUM OF 100 FOOT INTERVALS
 - C) DRIVEWAYS AS DIRECTED
 - I) ONE PER AREA.

PERMIT TO BLOCK WAY

1. NO STREET, ALLEY, PARKING LANE, OR SIDEWALK SHALL BE BLOCKED WITHOUT THE CITY FIRST APPROVING A PERMIT TO BLOCK WAY. APPLICATIONS FOR A PERMIT TO BLOCK WAY CAN BE OBTAINED AT THE CITY OF PIQUA ENGINEERING DEPARTMENT OR ONLINE AT THE CITY OF PIQUA WEBSITE: WWW.PIQUAOH.ORG EGOV SERVICES ONLINE DOCUMENTS.
2. APPLICATIONS FOR A PERMIT TO BLOCK WAY SHALL BE SUBMITTED TO THE CITY OF PIQUA ENGINEERING DEPARTMENT A MINIMUM OF 3 WORKING DAYS PRIOR TO THE REQUESTED BLOCKAGE.
3. APPLICATION SHALL INCLUDE A DETAILED DRAWING OF THE WORK ZONE LAYOUT AND INCLUDE SIGNAGE, CONES, BARRICADES, BARRELS ETC. ALL WORK ZONES SHALL CONFORM TO THE CURRENT EDITION OF THE OHIO MANUAL OF UNIFORM TRAFFIC CONTROL DEVICES.
4. IT SHALL BE THE APPLICANT/CONTRACTORS RESPONSIBILITY FOR PROVIDING AND MAINTAINING ALL NECESSARY SAFETY MATERIALS FOR THE SET UP OF THE WORK ZONE.
5. THE CITY OF PIQUA ENGINEERING DEPARTMENT SHALL INSPECT THE WORK ZONE PERIODICALLY TO ASSURE THE MAINTENANCE OF THE DEVICES.
6. ALL EXCAVATION/ REPAIR SHALL COMPLY WITH RIGHT-OF-WAY OPENING PERMIT REQUIREMENTS.

STREET OR ALLEY CLOSING PERMIT

1. NO STREET, ALLEY OR PARKING LANE SHALL BE CLOSED TO THRU TRAFFIC WITHOUT THE CITY FIRST APPROVING A STREET OR ALLEY CLOSING PERMIT. APPLICATIONS FOR A STREET OR ALLEY CLOSING PERMIT CAN BE OBTAINED AT THE CITY OF PIQUA ENGINEERING DEPARTMENT OR ONLINE AT THE CITY OF PIQUA WEBSITE: WWW.PIQUAOH.ORG . E-GOV SERVICES ONLINE DOCUMENTS.
2. APPLICATIONS FOR A STREET OR ALLEY CLOSING PERMIT SHALL BE SUBMITTED TO THE CITY OF PIQUA ENGINEERING DEPARTMENT A MINIMUM OF 5 WORKING DAYS PRIOR TO THE REQUESTED BLOCKAGE, EXCLUDING WEEKENDS AND HOLIDAYS.
3. APPLICANT SHALL BE RESPONSIBLE FOR NOTIFYING IN WRITING ALL ADJACENT PROPERTY OWNERS TO BE AFFECTED BY THE CLOSURE. THE CITY SHALL RECEIVE A COPY OF THE WRITTEN NOTICE AND A LIST OF THE PROPERTY OWNERS AND THEIR ADDRESS THAT HAVE BEEN NOTIFIED.
4. APPLICATION SHALL INCLUDE A DETAILED DRAWING OF THE WORK ZONE LAYOUT AND INCLUDE SIGNAGE, CONES, BARRICADES, BARRELS ETC. ALL WORK ZONES SHALL CONFORM TO THE CURRENT EDITION OF THE OHIO MANUAL OF UNIFORM TRAFFIC CONTROL DEVICES.
5. IT SHALL BE THE APPLICANT/CONTRACTORS RESPONSIBILITY FOR PROVIDING AND MAINTAINING NECESSARY SAFETY MATERIALS FOR HE SET UP OF THE WORK ZONE.
6. THE CITY OF PIQUA ENGINEERING DEPARTMENT SHALL INSPECT THE WORK ZONE PERIODICALLY TO ASSURE THE MAINTENANCE OF THE DEVICES.
7. ALL EXCAVATION/ REPAIR SHALL COMPLY WITH RIGHT-OF-WAY OPENING PERMIT REQUIREMENTS.

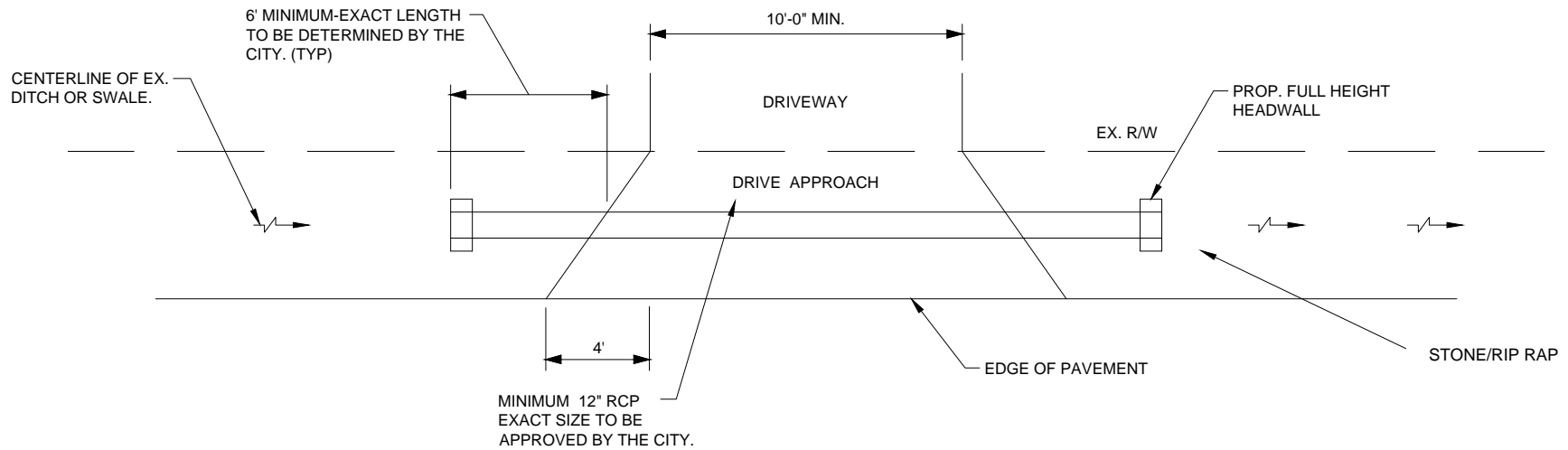

DRIVE WITH CULVERT

NOTES

- A. DRIVE APPROACHES SHALL BE CONSTRUCTED PER THE CITY STANDARDS AND APPROVAL
- B. ALL NEW CONSTRUCTION OR MODIFICATIONS OF DRIVE APPROACHES REQUIRE A CONCRETE APPROACH, REGARDLESS OF WHETHER THERE IS A SIDEWALK OR NOT. THE NEW APPROACH IS TO GO FROM EDGE OF EXISTING STREET OR PAVEMENT TO THE RIGHT OF WAY OR A MINIMUM OF 6'-0"
- C. ANY DRAINAGE ISSUES WILL HAVE TO BE ADDRESSED WHEN A DRIVEWAY IS INSTALLED OR MODIFIED
- D. IF THE EXISTING ROADWAY IS DISTURBED DURING CONSTRUCTION THE PROPERTY OWNER WILL BE RESPONSIBLE TO REPAIR ANY DAMAGE THE SATISFACTION OF THE CITY.
- E. THE PROPERTY OWNER MUST SUBMIT A DRAWING TO BE APPROVED BY THE CITY PRIOR TO CONSTRUCTION.
- F. THE EXACT SIZE AND LOCATION OF THE PROPOSED CULVERT AND HEADWALLS WILL BE DETERMINED BY THE CITY PRIOR TO CONSTRUCTION.

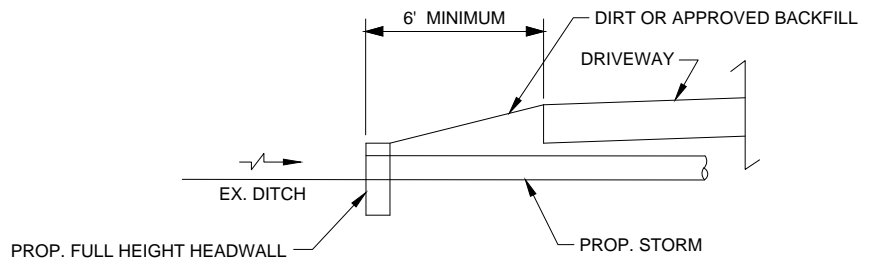
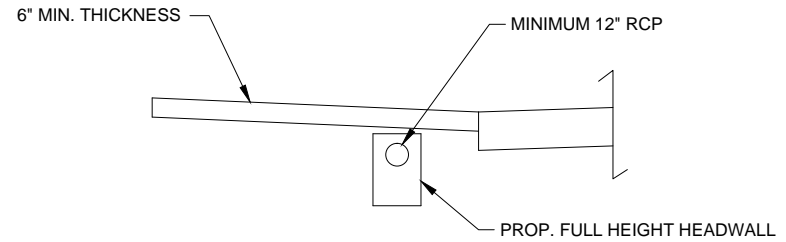

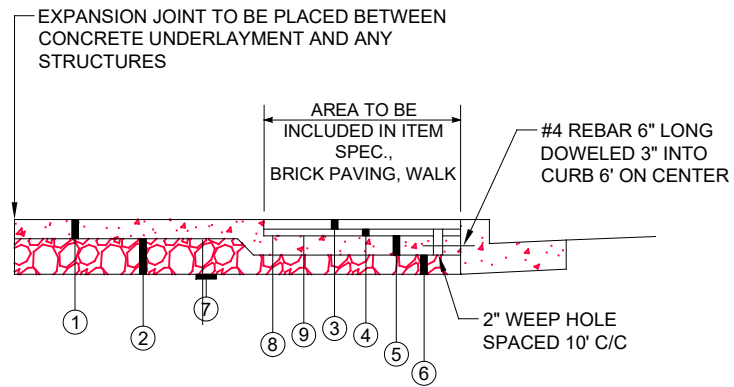

BRICK TYPICAL SECTION

- 1 ITEM 608, 5" CONCRETE WALK, AS PER PLAN APPLY 2 COATS OF SUPER DIAMOND CLEAR CURING AND SEALING COMPOUND, OR APPROVED EQUIVALENT PER MANUFACTURER'S RECOMMENDATION ON ALL SURFACES INCLUDING BACK OF CURB IMMEDIATELY AFTER FINISHING SURFACES.
- 2 ITEM 411, 8" AGGREGATE BASE, (IN 2 EQUAL 4" LIFTS), SATURATED WITH WATER PRIOR TO COMPACTION
- 3 ITEM SPECIAL, BRICK PACING, WALK (2--1/4" BRICK), (REFER TO CITY FOR SPECIFICATIONS)
- 4 3/4" ROLLED BITUMINOUS SETTING BED. (REFER TO CITY FOR SPECIFICATIONS)
- 5 ITEM 608, 4" CONCRETE UNDERLAYMENT, CURE & SEAL WITH ONE COAT OF DIAMOND CLEAR, OR ODOT APPROVED CURING COMPOUND.
- 6 ITEM 411, 5-3/4" AGGREGATE BASE SATURATE WITH WATER PRIOR TO COMPACTION
- 7 ITEM 204, SUBGRADE COMPACTION
- 8 ITEM 407, TACK COAT @ 0.10 GAL/S.Y. NEOPRENE MODIFIED ASPHALT.
9. NEOPRENE MODIFIED ASPHALT ADHESIVE.

MATERIALS:

A. BRICK PAVERS

1. MANUFACTURED FROM EXTRUDED FIRECLAY OR SHALE AND FIRE TO PRODUCE A DENSE PAVER THOROUGHLY ANNEALED AND EVENLY BURNED SO THAT WHEN BROKEN THEY SHOW A UNIFORMLY DENSE STRUCTURE FREE FROM LIME, AIR POCKETS, AND MARKED LAMINATIONS.
2. PROVIDE BRICK PAVERS IN WALK AREAS IN ACCORDANCE WITH ASTM C 902, CLASS SX, TYPE I.
3. PAVER THICKNESS SHALL BE 2- 1/4" (MINIMUM).
4. PROVIDE A BEVEL-EDGE BRICK PAVER OF QUALITY AND COLOR TO MATCH THE TONE AND HUE OF THE BRICKS LISTED BELOW AS APPROVED BY THE ENGINEER. PROVIDE THREE REPRESENTATIVE BRICKS FOR COLOR APPROVAL.

BRICK PAVER SPECIFICATIONS:

#30 CLEAR RED RUSTIC DIMENSIONS 2-1/4" X 4" X 8" AS MANUFACTURED BY WHITACRE GREER BRICK FOR WALKS AND CURB RAMPS BRICK MUST MEET DIMENSIONS AND QUALITY, CONTRACTOR IS TO DISCARD ANY DEFECTIVE BRICKS.

COLOR BLENDING INSTRUCTIONS:

PAVERS ARE TO BE LAID FROM MULTIPLE PALLETS TO ACCOMPLISH A UNIFORM BLENDING OF COLORS.

5. CLAY PAVERS SHALL HAVE A MINIMUM COMPRESSIVE STRENGTH OF 7,500 PSI WITH NO INDIVIDUAL STONE TESTING LESS THAN 7,200 PSI.
6. CONTRACTOR SHALL NOT INSTALL ANY BRICK PAVING MATERIAL INCLUDING CONCRETE UNDERLAYMENT UNTIL THE SHOP DRAWINGS HAVE BEEN APPROVED NY THE CITY.

B. INSTALLATION OF BRICK PAVERS

1. PLACE THE PAVERS BY HAND WHEN THE MODIFIED ASPHALT ADHESIVE IS DRY TO THE TOUCH. PLACE IN STRAIGHT COURSES CONTROLLED BY ACCURATELY PLACED STRIKING LINES, WITH HAND TIGHT JOINTS AND UNIFORM TOP SURFACE. KEEP GOOD ALIGNMENT AND THE PATTERN THAT IS SHOWN ON THE PLANS OR APPROVED SHOP DRAWINGS. ESTABLISH COURSING PERPENDICULAR TO STREET CENTERLINE.
 2. PROTECT NEWLY LAID PAVERS AT ALL TIMES BY PANELS OF PLYWOOD ON WHICH THE INSTALLER STANDS. ADVANCE THESE PANELS OF PLYWOOD AS WORK ARE PROGRESSES. KEEP THE PLYWOOD PROTECTION IN AREAS WHICH WILL BE SUBJECTED TO CONTINUED MOVEMENT OF MATERIALS AND EQUIPMENT.
- A. JOINT TREATMENT
1. VARY HAND-TIGHT JOINTS FROM 0" TO MAXIMUM 3/16" WITH 1/8" BEING THE AVERAGE JOINT DIMENSION. FILL JOINTS WITH STABILIZED JOINT FILLER CONSISTING OF SAND AND SANDLOCK MIXTURE, SEE 4. THROUGH 7 FOR INSTALLATION.
 2. SAW BRICK PAVERS TO FIT TIGHTLY AROUND ALL OBSTACLES WITHIN THE PAVING AREA. MEET JOINTING TOLERANCE OF HAND-TIGHT JOINTS. FIT PAVERS AROUND CIRCULAR OBJECTS WITH CIRCULAR OR ARCH FORM, NOT ANGULAR.

3. SAW BRICK PAVERS TO FIT WITHIN THE PATTERN AROUND OBSTACLES AND PROVIDE A SURFACE AREA GREATER THAN ONE-THIRD A FULL-SIZE BRICK, UNLESS APPROVED BY THE CITY AS THE ONLY ALTERNATIVE.

4. BLENDING SANDLOCK WITH SAND

- A. UNIFORMLY BLEND 1 1/2" LBS OF SANDLOCK PER 100 LBS OF DRY JOINT SAND MATERIAL ON-SITE MIXING RATIO MAY BE ADJUSTED BETWEEN 1 AND 1 3/4 LBS PER 100 LBS OF SAND
- B. BLENDING CAN BE ACCOMPLISHED EITHER BY HAND MIXING OR DRY MIXING IN A MECHANICAL MIXED ON SITE, OR MATERIAL CAN BE PRE-MIXED IN PROPER PROPORTIONS AND DELIVERED TO THE WORK SITE. MIX ONLY ENOUGH MATERIAL TO COMPLETE FILL THE JOINTS OF THE PAVERS WHICH HAVE BEEN SET THAT DAY. ONCE MIXED MATERIAL MUST REMAIN COMPLETELY DRY PRIOR TO APPLICATION; PROPER PRECAUTION SHOULD BE TAKEN TO PROTECT MATERIALS FROM EXCESSIVE MOISTURE EXPOSURE PRIOR TO USE. WHILE SANDLOCK CAN BE ADDED TO DAMP SAND, IT SHOULD NOT BE USED WITH SAND THAT IS WET. BE SURE TO COVER SAND PILES AT THE END OF EVERY WORK DAY OR IF RAIN IS EXPECTED.

5. PLACEMENT OF MIXED JOINT MATERIAL

SPREAD MIXED JOINT SAND MATERIAL OVER PAVED SURFACE EVENLY; COMPLETELY COVER PAVER SURFACE WITH THIN LAYER OF MIXED AGGREGATE AND SANDLOCK. USING A PUSH BROOM SWEEP THE MIXTURE INTO THE JOINTS WITH A SLIGHT POUNDING MOTION. CONTINUE THIS PROCEDURE UNTIL ALL JOINTS ARE FULL AND SAND CAN NO LONGER BE VIBRATED INTO THEM.

6. ACTIVATION OF BONDING

- A. CAREFULLY SWEEP ENTIRE PAVEMENT CLEAN TO REMOVE SANDLOCK MIXTURE FROM THE PAVER SURFACE, EXCESS SAND MATERIALS INCLUDING CHAMFERED AREAS MUST BE SWEEPED OFF PAVED SURFACE AND REMOVED. POWER BROOMS OR BLOWERS ARE RECOMMENDED FOR LARGE AREAS. EXCESS MATERIAL REMAINING ON SURFACE AFTER THE MIXTURE HAS BEEN ACTIVATED IS DIFFICULT TO REMOVE.
- B. THE PAVED AREA, INCLUDING JOINTS, SHOULD BE FLOODED WITH WATER TO ACTIVATE THE SANDLOCK ADDITIVE, CARE MUST BE TAKEN TO AVOID WASHING SAND FROM THE JOINTS. DO NOT USE HIGH PRESSURE SPRAY FOR FLOODING SURFACE. AFTER FLOODING, AREA SHOULD BE COMPLETELY DRY, INCLUDING JOINTS, PRIOR TO OCCURRING TRAFFIC TO USE PAVED AREAS. DRYING TYPICALLY OCCURS WITHIN 2 TO 6 HOURS, DEPENDING UPON WEATHER CONDITIONS

7. CLEANUP

IF SANDLOCK IS LEFT ON SURFACE, IT WILL EMULSIFY. DEPENDING ON SEVERITY, IT MAY COME OFF WITH WATER AND BRUSHING; IF SEVERE, IT MAY REQUIRE PRESSURE WASHING, NEVER LEAVE DRY SANDLOCK RESIDUE ON SURFACE.

BITUMINOUS SETTING BED FOR BRICK PAVERS

THIS WORK SHALL CONSIST OF CONSTRUCTING A BITUMINOUS BRICK SETTING BED, PLACING THE PAVER BRICK AND SAND IN THE JOINTS WITH SPECIFIED MATERIALS IN REASONABLY CLOSE CONFORMITY WITH LINES, GRADES, AND DIMENSIONS SHOWN ON THE PLANS OR ESTABLISHED BY THE ENGINEER. ASPHALT CEMENT TO BE USED IN THE BITUMINOUS SETTING BED SHALL CONFORM TO ASTM DESIGNATION D-3381. THE VISCOSITY GRADE A.C. 20. THE FINE AGGREGATE TO BE USED IN THE BITUMINOUS SETTING BED SHALL BE CLEAN, HARD SAND WITH DURABLE PARTICLES AND "COURSE" TO "FINE" AND ALL PASSING THE NO. 4 SIEVE, AND IT SHALL MEET THE GRADUATION REQUIREMENTS WHEN TESTED IN ACCORDANCE WITH THE STANDARD METHOD OF TEST FOR SIEVE OR SCREEN ANALYSIS OF FINE AND COARSE AGGREGATES ASTM DESIGNATION C-136-81. THE DRIED FINE AGGREGATE SHALL BE COMBINED WITH HOT ASPHALT CEMENT, AND THE MIX OF MATERIALS SHALL BE SEVEN (7) PERCENT ASPHALT CEMENT AND NINETY-THREE (93) PERCENT FINE AGGREGATE. EACH TON SHALL BE APPORTIONED BY WEIGHT IN THE APPROXIMATE RATIO OF 145 LBS. ASPHALT TO 1,855 LBS. SAND. THE CONTRACTOR SHALL DETERMINE THE EXACT PROPORTIONS TO PRODUCE THE BEST POSSIBLE MIXTURE FOR CONSTRUCTION OF THE BITUMINOUS SETTING BED TO MEET CONSTRUCTION REQUIREMENTS.

NEOPRENE- MODIFIED ASPHALT ADHESIVE UNDER BRICK PAVERS

MASTIC (ASPHALT ADHESIVE)
SOLIDS BASE 75+1%3
LBS./GAL 8-8.5 LB.
SOLVENT VARSOL (OVER 100 DEGREE F FLASH)
BASE (2% NEOPENE, 10% FIBERS, 88% ASPHALT)
MELTING POINT- ASRM D-36 200 DEGREES F MIN.
PENETRATION-77 DEGREES 100 GRAM LOAD 5 SECOND (.1MM) 23-27
DUCTILITY- ASTM D-113-44@ 25 DEGREES C (5CMS/MINUTE) 125 CM.
MIN
BITUMINOUS SETTING BED TO BE PLACED BY EXPERIENCED SUBCONTRACTOR IN THIS TRADE WHO HAS PERFORMED A MINIMUM OF FIVE (5) OTHER PROJECTS OF SIMILAR SIZE WHICH INCLUDE BITUMINOUS SETTING BEDS. THE CONTRACTOR PLACING THE BITUMINOUS SETTING BED SHALL ALSO PLACE AND INSTALL THE ACTUAL BRICK PAVERS. SUBMIT EXPERIENCE RECORD OF BRICK SUB-CONTRACTOR AND LIST OF OTHER PROJECTS OF SIMILAR SIZE, DIFFICULTY, AND TYPE. THE CONCRETE SUB-SLAB SURFACE SHALL BE CLEANED, FREE OF DUST, DIRT, FOREIGN MATERIAL, PLASTER, SEALER, CURING COMPOUNDS, AND FROM OIL PRIOR TO PLACEMENT OF BITUMINOUS SETTING BED. BRICK INSTALLATION CONTRACTOR SHALL EXAMINE THE AREAS TO BE COVERED AND ADVISE PRIME CONTRACTOR AND ENGINEER OF ANY EXISTING CONDITIONS OR SURFACE CONTAMINATION WHICH SHALL REQUIRE CORRECTION PRIOR TO PLACING BITUMINOUS SETTING BED. TO INSTALL THE SETTING BED OVER THE BASE SURFACE, PLACE DEEP CONTROL BARS DIRECTLY OVER THE BASE. THE DEPTH OF THE CONTROL BARS MUST BE SET CAREFULLY TO BRING PAVERS, WHEN LAID TO PROPER GRADE.

THICKNESS OF THE FINISHED SETTING BED SHALL BE NO MORE THAN 1" OR LESS THAN 1/2". THE SETTING BED SHALL BE COMPACTED WITH A MECHANICAL TAMPING DEVICE TO A NOMINAL DEPTH OF 3/4" WHILE STILL HOT. THE THICKNESS SHALL BE ADJUSTED SO THAT WHEN THE ASPHALT BLOCK OR BRICK PAVERS ARE PLACED, THE TOP SURFACE OF THE PAVERS WILL BE AT THE REQUIRED FINISHED GRADE. BE SURE FINISHED SURFACES DO NOT VARY FROM THE TRUE LINES, LEVELS, OR GRADE BY MORE THAN 1/8" IN TEN (10) FEET WHEN MEASURING WITH STRAIGHT EDGES.

A COATING OF TWO (2) PERCENT NEOPRENE-MODIFIED ASPHALT ADHESIVE SHALL BE APPLIED BY SQUEEZING OR TROWELING OVER THE TOP SURFACE OF THE BITUMINOUS SETTING BED SO AS TO PROVIDE A BOND UNDER THE PAVERS. IF IT IS TROWELED, THE TROWEL SHALL BE SERRATED WITH SERRATIONS NOT TO EXCEED ONE-SIXTEENTH (1/16) OF AN INCH.

ON ALL DRIVEWAYS AREAS, CROSSWALKS, OR OTHER WHICH SHALL RECEIVE VEHICULAR TRAFFIC OVER BRICK PAVERS, PRIME CONCRETE, SUB SLAB SURFACE WITH EMULSIFIED ASPHALT (RS-1OR CRS-1) BRICK PAVERS WILL BE SUPPLIED BY THE CONTRACTOR. BRICK PAVERS SUPPLIED WILL BE MANUFACTURED FROM EXTRUDED FIRECLAY OR SHALE AND BE FIRED TO PRODUCE A DENSE PAVER WITH AN ABSORPTION OF LESS THAN 5%(IN A 24 HOUR COLD WATER ABSORPTION TEST), A MAXIMUM SATURATION OF COEFFICIENT OF 0.78 MINIMUM. AVERAGE COMPRESSIVE STRENGTH SHALL NOT BE LESS THAN 10,000 P.S.I., THE PAVERS MUST BE CAPABLE OF WITHSTANDING AT LEAST THE EQUIVALENT OF 50 CYCLES OF FREEZE-THAW CONDITIONS. THE PERMISSIBLE TOLERANCE FOR INDIVIDUAL PAVERS SHALL CONFORM TO THE ASTM DESIGNATION C-902-79A. PAVER SIZE TO BE UTILIZED IN BRICK STRIP IN PEDESTRIAN, DRIVEWAY, AND ALLEY AREAS SHALL BE 2 1/4" THICK, 4" WIDE AND 8" LONG. BRICK PAVERS FURNISHED BY CONTRACTORS SHALL BE AS MANUFACTURED BY WHITACRE-GREER BEVELED EDGE VACUUM DRY-PRESSED SOLID PAVER OR EQUAL, 4X8X2 1/4" THICK. THE COLOR SHALL BE WHITACRE-GREER CLEAR RED RUSTIC #30, OR APPROVED EQUAL. NO PAVERS WHICH ARE CHIPPED, CRACKED OR OTHERWISE DAMAGED ARE TO BE INSTALLED. AFTER THE MODIFIED ASPHALT ADHESIVE IS APPLIED, CAREFULLY PLACE THE PAVERS BY HAND IN STRAIGHT COURSES WITH HAND TIGHT JOINTS AND UNIFORM TOP SURFACE. GOOD ALIGNMENT MUST BE KEPT, AND THE PATTERN SHALL BE THAT SHOWN ON THE PLANS. HAND TIGHT JOINTS SHALL READ FROM 0" TO MAXIMUM OF 1/8" FOR BRICK PAVERS. SWEEP DRY MIXTURE OF ONE (1) PART COLORED PORTLAND CEMENT TO MATCH COLOR OF PAVERS AND THREE (3) PARTS SAND UNTIL JOINTS ARE COMPLETELY FILLED. FOG LIGHTLY WITH WATER, CEMENT STAINS THAT REMAIN SHOULD BE CLEANED. PORTLAND CEMENT WITH COLOR ADDED SHALL CONFORM TO ASTM C-150. SAND SHALL CONFORM TO ASTM C-144.

ALL PAVERS SHALL BE RETAINED BY SIDEWALK, CURB, OR ROADWAY. CUT PAVERS PAVERS WHICH ARE REQUIRED TO PROVIDE DESIRED LAYOUT AND PATTERN AS SHOWN ON DRAWINGS. ALL CUTTINGS SHALL BE SO ACCOMPLISHED SO AS TO LEAVE A CLEAN EDGE TO THE TRAFFIC SURFACE. USE MASONRY SAW AND OTHER APPROVED TOOLS FOR CUTTING. VERY DIMENSIONS SHOWN ON DRAWINGS FOR PAVED AREAS AND OBTAIN APPROVAL FROM ENGINEER FOR AN DIMENSION CHANGES RECOMMENDED, IN WIDTH OF PAVED AREAS, AND ANY PATTERN CHANGES. DIMENSION CHANGES SHALL BE ALLOWED TO COMPENSATE FOR UTILIZATION OF FULL BRICKS AND TO MINIMIZE CUTTING OF BRICKS ONLY.

CONTRACTOR TO PROTECT THE FINISHED WORK FROM DAMAGE THROUGH THE CONSTRUCTION PERIOD TERMINATING AT FINAL ACCEPTANCE OF THE ENTIRE PROJECT. AT PROJECT COMPLETION, SWEEP AREA AND REPAIR ANY DAMAGED WORK. THE CONTRACTOR SHALL PROTECT ALL CONCRETE SUB-SLAB SURFACES Poured FROM DAMAGE OR CHIPPING BY RESIDENTIAL OR VEHICULAR TRAFFIC UNTIL BRICK IS LAID AND WORK ACCEPTED BY ENGINEER.

THE BRICK CONTRACTOR SHALL BE INVOLVED WITH THE PROJECT ASSISTING AND ADVISING THE CONCRETE WALK, DRIVES, AND ADJACENT BRICK PAVED AREAS. MINOR ADJUSTMENTS IN THE CONCRETE INSERT DIMENSIONS SHOWN ON PLANS MAY BE MADE AS APPROVED BY THE CITY TO MINIMIZE THE CUTTING OF BRICK PAVERS AND OBTAIN OPTIMAL PATTERN PLACEMENT. THE CONTRACTOR SHALL PROVIDE THE CITY A REPRESENTATIVE TYPICAL PAVED AREAS TO BE USED IN DETERMINING THE FINAL INSERT DIMENSIONS CONSTRUCTED IN CONCRETE BY THE CONCRETE CONTRACTOR. THE REPRESENTATIVE BRICK AREAS SHALL DEMONSTRATE FINAL ARRANGEMENT OF PAVERS IN REGARD TO DIMENSIONS AND PATTERN. AFTER THE ENGINEER HAS REVIEWED THE REPRESENTATIVE CONSTRUCTED AREA AND AGREEMENT IS REACHED AS TO ALL OF THE FINAL DETAILS OF THE BRICK PAVED AREAS, CONTRACTOR MAY COMMENCE CONSTRUCTION. THE SAMPLE CONSTRUCTION AREA WILL THEN BECOME THE STANDARD FOR ALL FUTURE WORK.

CITY OF PIQUA



BITUMINOUS SETTING BED FOR PAVERS

REVISIONS:

DATE APPROVED:
DEC. 2016

PAGE No.
300-20

500 - General

UTILITIES AGENTS

**CITY OF PIQUA- PUBLIC WORKS
PARKS AND STREETS**

859 SOUTH MAIN STREET
PIQUA, OHIO 45356
937-778-2095

CITY OF PIQUA- UNDERGROUND UTILITIES

8620 N. CR. 25A
PIQUA, OHIO 45356
937-778-2018

CITY OF PIQUA- POWER DISTRIBUTION

201 HEMM AVENUE
PIQUA, OHIO 45356
937-778-2077

PIONEER RURAL ELECTRIC-POWER SERVICE

344 WEST US ROUTE 36
PIQUA, OHIO 45356
937-778-2523

DPL-POWER SERVICE

2385 CAMPBELL ROAD
SIDNEY, OHIO 45365
937-331-3315

CENTER POINT/VECTREN-GAS

2395 E. MAIN STREET
DANVILLE, INDIANA 46122
937-440-1844

ATT- PHONE SERVICE CHARTER COMMUNICATION-CABLE

GUY SPIDEL 3691 TURNER COMMUNICATION
937-296-3699 DAYTON, OHIO 45414
GS1878@ATT.COM

OHIO UTILITIES PROTECTION SERVICE

3 WORKING DAYS BEFORE YOU DIG
TOLL FREE 1-800-362-2764

SEEDING

A. ALL AREAS DESIGNATED FOR SEEDING SHALL HAVE A MINIMUM OF 6" OF TOPSOIL OVER THE ENTIRE AREAS. THE AREA SHALL BE RAKED, ROLLED, AND DRESSED READY FOR SEEDING. NOT STONE OVER 1" IN SIZE PERMITTED.

DRAINS

A. ALL FIELD OR STORM DRAINS WHICH ARE ENCOUNTERED DURING CONSTRUCTION SHALL BE REPAIRED AND PROVIDED WITH UNOBSTRUCTED OUTLETS AS APPROVED AND DIRECTED NY THE CITY AND MARKED ON THE RECORD DRAWINGS.

CONNECTIONS TO EXISTING PIPE

A. WHERE THE PLANS PROVIDE FOR PROPOSED CONDUIT TO BE CONNECTED TO, OR TO CROSS EITHER OVER OR UNDER AN EXISTING SEWER, IT SHALL BE THE RESPONSIBILITY OF THE CONTRACTOR TO LOCATE THE EXISTING PIPE BOTH AS TO LINE AND GRADE BEFORE STARING TO LAY THE PROPOSED CONDUIT.

UTILITIES

A. THE MAXIMUM LENGTH OF ANY UTILITY TRENCH TO BE OPEN AT ANY TIME SHALL BE 250' UNLESS OTHERWISE APPROVED.
B. ALL UNDERGROUND UTILITIES ARE TO BE WITHIN THE PUBLIC RIGHT OF WAY.

COMPACTION METHODS

A. FLOODING SHALL NOT BE PERMITTED.
B. MECHANICAL DEVICES, HAND DEVICES VIBRATING PLATES OR OTHER EQUIPMENT APPROVED BY THE CITY IS ACCEPTABLE 1' ABOVE PIPE IN UNIFORM LIFTS OF 12" (LOOSE DEPTH) OF EXISTING NATIVE MATERIAL AND 6" OF GRANULAR BACKFILL. THE HEIGHT OF LIFTS WILL DEPEND UPON THE TYPE OF MECHANICAL EQUIPMENT BEING USED. THE HEIGHT WILL BE 6" FOR HAND OPERATED TOOLS AND UP TO 12" ON EQUIPMENT MOUNTED TOOLS. THE COMPACTION EQUIPMENT SHALL BE CAPABLE OF COMPACTING THE MATERIAL UNDER THE HAUNCH OF HE PIPE.
C. DENSITY FOR THE ABOVE METHODS SHALL BE NO LESS THAN THAT OF THE SURROUNDING GROUND UNLESS OTHERWISE SPECIFIED.

DISPOSAL OF SURPLUS MATERIAL

A. THE CITY MAY AT THEIR DISCRETION REQUIRE THAT SURPLUS MATERIAL BE DEPOSITED AT A LOCATION DESIGNATED WITHIN A TWO-MILE RADIUS OF THE WORK SITE.

TYPICAL NOTES-ALL SUBDIVISION CONSTRUCTION DRAWINGS.

A. ALL CONSTRUCTION METHODS AND MATERIALS SHALL COMPLY WITH THE CITY ENGINEERING STANDARDS OR ODOT WHICHEVER IS MORE RESTRICTIVE.
B. ALL COMPACTION SHALL MEET THE CITY REQUIREMENTS. IF TESTING OF COMPACTED AREAS IS REQUESTED BY THE CITY, SAID TESTING SHALL BE PERFORMED AT THE EXPENSE OF THE DEVELOPER.
C. THE CITY WILL LOCATE AREAS IN NEED OF UNDERCUTTING UNLESS THE DEVELOPER CHOOSES TO HAVE AT HIS EXPENSE AN INDEPENDENT APPROVED TESTING COMPANY TO DETERMINE UNSUITABLE MATERIAL AREAS THAT NEED UNDERCUTTING.
D. ALL EMBANKMENT AREAS SHALL BE COMPACTED TO A MINIMUM OF 95% OF ASTM D698 STANDARD PROCTOR CURVE AND TESTED TO REPRESENT A DEPTH OF 12" UNLESS OTHERWISE SPECIFIED BY THE CITY.
E. ALL UNPAVED AREAS WITHIN THE STREET RIGHT-OF-WAY SHALL BE SEEDED WITHIN 48 HOURS AFTER THE CURB IS BACKFILLED. STAKED STRAW BALES MAY BE REQUIRED IN ADDITION TO SEEDING CONTROL EROSION IF REQUESTED BY THE CITY.
F. STORM WATER POLLUTION PREVENTION SHOULD BE A HIGH PRIORITY ON ALL CONSTRUCTION PROJECTS. ON ALL PROJECTS WHICH DISTURB AT LEAST 1 ACRE OF SOIL, A NPDES PERMIT IS REQUIRED FROM OEPA AND A COPY OF THE PERMIT MUST BE ON FILE AT THE CITY OFFICE BEFORE CONSTRUCTION BEGINS.

CITY OF PIQUA



GENERAL NOTES

REVISIONS:
12-14-16 BG
05-02-18 BG
11-02-20 KK

DATE APPROVED:
DEC. 2016

PAGE No.
500-1

BORING / JACKING

A. MATERIALS

CASING PIPE SHALL BE WELDED STEEL PIPE CONFORMING TO AWWA C-202

B. INSTALLATION (CASING PIPE)

- 1. FURNISH PROCEDURE METHODS TO THE CITY FOR APPROVAL.
- 2. ALL METHODS AND PROCEDURES SHALL BE APPROVED BY THE CITY PRIOR TO CONSTRUCTION.
- 3. ADEQUATELY SUPPORT ALL TRENCHES AND BORING/ JACKING PITS.
- 4. INSTALL TO LINE AND GRADE SHOWN.

C. INSTALLATION (CARRIER PIPE)

- 1. PLACE CONDUITS IN CASING PIPE TO SAME RELATIVE POSITIONS AS ADJACENT DUCT BY USE OF SPACERS.
- 2. FILL THE SPACE BETWEEN CONDUITS INSIDE THE CASING PIPE WITH CLEAN SAND OR OTHER APPROVED MATERIALS AS APPROVED BY THE CITY.

STEEL CASING PIPE

- A. STEEL PIPE SHALL HAVE A MINIMUM YIELD STRENGTH OF 35,000 PSI.
- B. JOINTS BETWEEN THE SECTIONS OF PIPE SHALL BE FULLY WELDED AROUND THE COMPLETE CIRCUMFERENCE OF THE PIPE.
- C. SIZE- A MINIMUM OF 4" GREATER THAN THE LARGEST OUTSIDE DIAMETER OF THE CARRIER PIPE.
- D. A STEEL CASING PIPE WILL BE REQUIRED FOR STORM SEWER, WATERMAIN, AND SANITARY SEWER.

DIAMETER NOMINAL (INCHES)	NOMINAL THICKNESS (INCHES)
10 AND UNDER	0.188
12 & 14	0.250
16	0.281
18	0.312
20&22	0.344
24	0.375
26	0.406
28	0.438
30	0.469
32	0.500
34 & 36	0.532
38	0.562
40	0.594
42	0.625
44 & 46	0.657
48	0.688
50	0.719
52	0.750
54	0.781
56 & 58	0.812
60	0.844
62	0.875
64	0.906
66 & 68	0.938
70	0.969
72	1.000

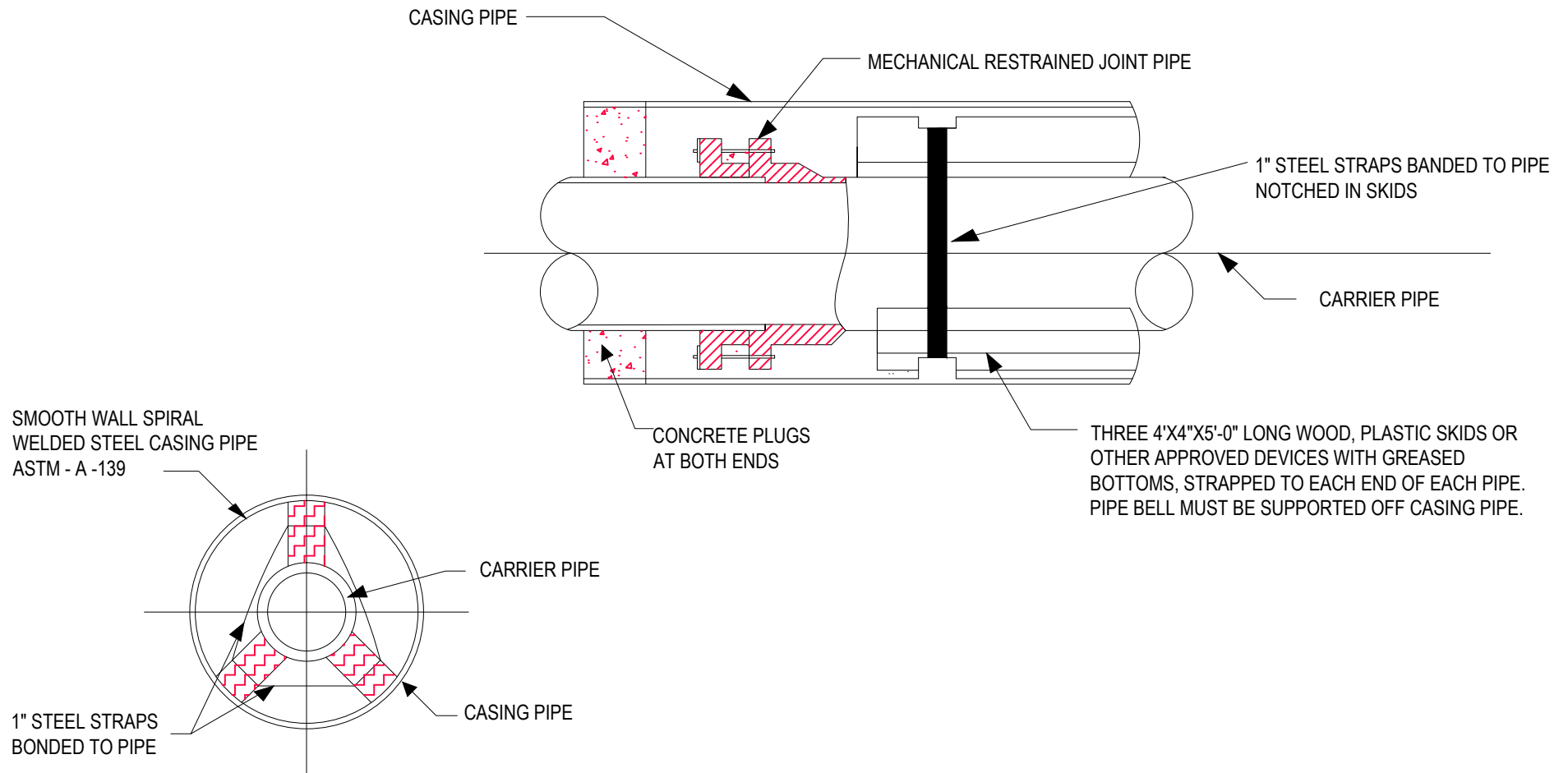

CITY OF PIQUA



CASING PIPE DETAIL

REVISIONS:

12-15-16 BG

DATE APPROVED:
DEC. 2016

PAGE No.
500-3

NOTES

LISTED BELOW ARE CONSTRUCTION REGULATIONS GOVERNING CONSTRUCTION ACTIVITIES IN THE VICINITY OF TREES. THE FOLLOWING REGULATIONS APPLY TO ALL TYPES OF CONSTRUCTION ACTIVITY BEING PERFORMED WITHIN OR IN CLOSE PROXIMITY TO PUBLIC RIGHT-OF-WAY AND EASEMENTS.

- A. FOR TREES MEASURING 38 INCH CIRCUMFERENCE (EQUIVALENT 12" DIAMETER) OR LESS, SOIL EXCAVATION WORK OR ROOT CUTTING SHALL NOT OCCUR CLOSER THAN 3 FEET FROM THE OUTER BARK OF THE TREE. THE CIRCUMFERENCE OF THE TREE HERE AND ELSEWHERE IN THESE REQUIREMENTS SHALL BE TAKEN 2 FEET ABOVE GROUND LEVEL. FOR MULTI-STEMMED TREES, THE CIRCUMFERENCE SHALL BE TAKEN AT THE NARROWEST POINT WITHIN THE FIRST 2 FEET ABOVE THE GROUND SURFACE.
- B. FOR TREES MEASURING GREATER THAN 38 INCH CIRCUMFERENCE, SOIL EXCAVATION WORK OR ROOT CUTTING SHALL NOT OCCUR CLOSER THAN THE DISTANCE MEASURED BY THE CIRCUMFERENCE OF THE TREE, OR A MAXIMUM DISTANCE OF 6 FEET, WHICHEVER IS LESS.
- C. SOIL EXCAVATION WORK IS PERMITTED CLOSER THAN THE DISTANCE PARAMETERS ESTABLISHED UNDER THE ABOVE TWO CATEGORIES PROVIDED ALL EXCAVATION OF SOIL IS ACCOMPLISHED BY HAND SHOVEL OR AUGER, AND NO ROOTS GREATER THAN 2 INCH DIAMETER ARE SEVERED.
- D. IF THERE IS AN INABILITY TO PERFORM THE REQUIREMENTS ESTABLISHED UNDER THE AFOREMENTIONED THREE SITUATIONS A REPRESENTATIVE FROM THE CITY SHALL BE CALLED TO THE TREE SITE TO MAKE AN INSPECTION AND RECOMMENDATION PERTAINING TO THE NEED TO REMOVE THE TREE UNLESS OTHER PROVISIONS ARE SPECIFIED; IN THE EVENT REMOVAL BECOMES NECESSARY, TREES REMOVED BY THE CITY FORCES OR CITY CONTRACT WILL BE REMOVED AND REPLACED BY THE CITY AT CITY COST. TREES REQUIRED TO BE REMOVED BY PRIVATE CONTRACTORS, INVESTOR -OWNED PUBLIC UTILITY COMPANIES, OR BY OTHERS WHO ARE PERMITTED TO PERFORM MAINTENANCE AND REPAIR WORK IN THE PUBLIC RIGHT -OF -WAY AND EASEMENT AREAS SHALL REMOVE SAID TREES AT THEIR COST AND EFFORT AND FURTHERMORE SHALL REPLACE THAT TREE WITH A SUITABLE SIZE TREE AND VARIETY PER THE REQUIREMENTS OF THE CITY.

- E. IN THE EVENT REMOVAL OF THE TREE IS REQUIRED BY PRIVATE AND PUBLIC UTILITIES, CONTRACTORS, AND OTHERS UNDER LIFE THREATENING OR RELATED SITUATIONS REMOVAL OF THE TREE (S) IS AUTHORIZED WITHOUT WRITTEN CITY AUTHORIZATION, PROVIDING PROPER FOLLOW-UP WRITTEN DOCUMENTATION IS PROVIDED IN ACCORDANCE WITH THE CITY PUBLIC RIGHT-OF-WAY OPENING AND EXCAVATION AND REPLACEMENT OF THE TREE(S) IS SCHEDULED TO THE SATISFACTION OF THE CITY.
- F. CONSTRUCTION TECHNIQUES TO REPAIR OR REPLACE SIDEWALKS AND CURBS USUALLY INVOLVE CUTTING OR SEVERING TREE ROOTS, IN WHICH THE ABOVE CRITERIA MAY APPLY. HOWEVER OTHER INNOVATIVE CONSTRUCTION TECHNIQUES TO REPAIR OR REPLACE SIDEWALKS AND CURBS, SUCH AS ASPHALT WEDGES, GRINDING, LANDSCAPE PAVERS, CONCRETE RAMPS, ETC. TO PROTECT TREE ROOTS TO AVOID THE REQUIREMENT OF TREE REMOVAL MAY BE APPROVED BY THE CITY URBAN FORESTER, AND WILL BE BASED ON EACH INDIVIDUAL REQUEST.
- G. CONSTRUCTION PROJECTS THAT INVOLVE THE REMOVAL OF CURBS AND GUTTERS OR RESURFACING PROJECTS MAY REQUIRE TRIMMING OF THE TREES ALONG THE TREE LAWN. THIS TRIMMING IS TO BE COORDINATED WITH THE CITY URBAN FORESTER PRIOR TO ANY WORK TAKING PLACE. THE TRIMMING WILL BE DONE TO REMOVAL ALL THE OBSTRUCTIVE BRANCHES TO PERMIT THE LARGEST PIECE OF EQUIPMENT TO PASS UNDER THE TREE'S BRANCHES WITHOUT DISTURBING ANY OF THE TREE'S LIMBS. ALL PRUNING MUST BE DONE ACCORDING TO ANSI A300 STANDARDS.
- H. ALL ARBORICULTURE WORK THAT IS PERFORMED WITHIN THE CITY SHALL CONFORM TO Z133 ANSI STANDARDS UNDER THE LATEST REVISION.

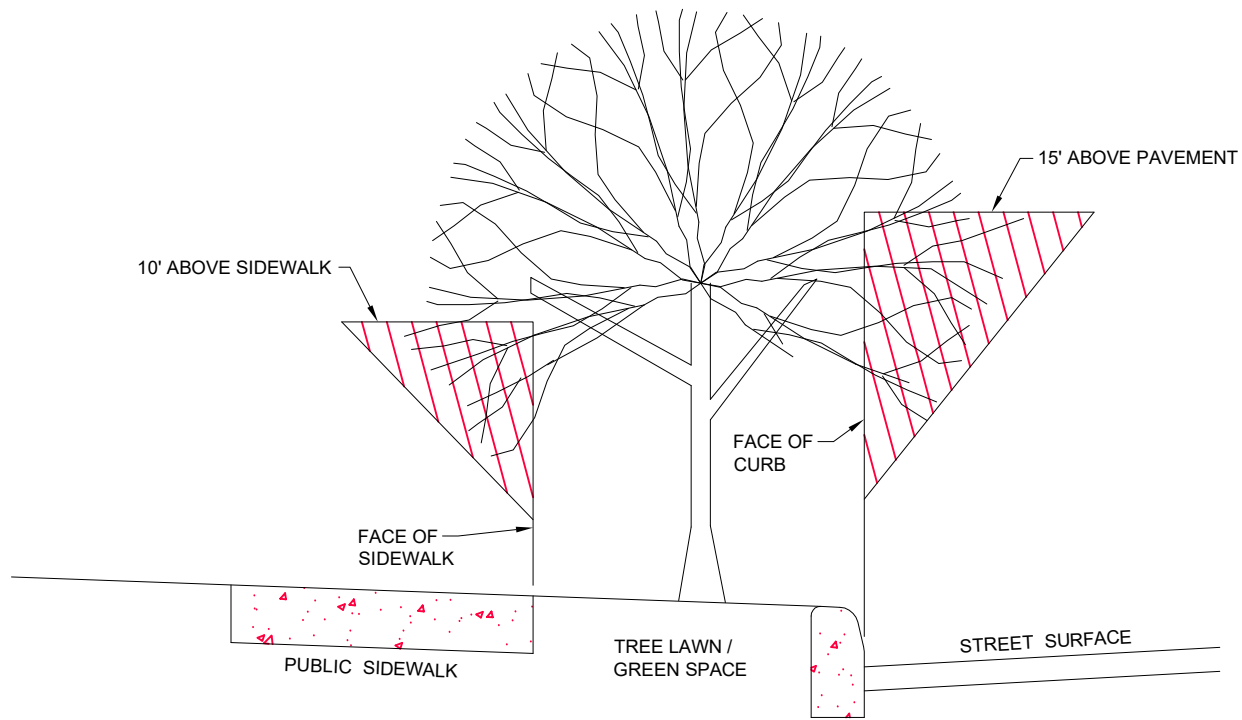

TREE TRIMMING DETAIL

NOT TO SCALE

CITY OF PIQUA



CONSTRUCTION NEAR TREES

REVISIONS:

DATE APPROVED:
DEC. 2016

PAGE No.

500-4A

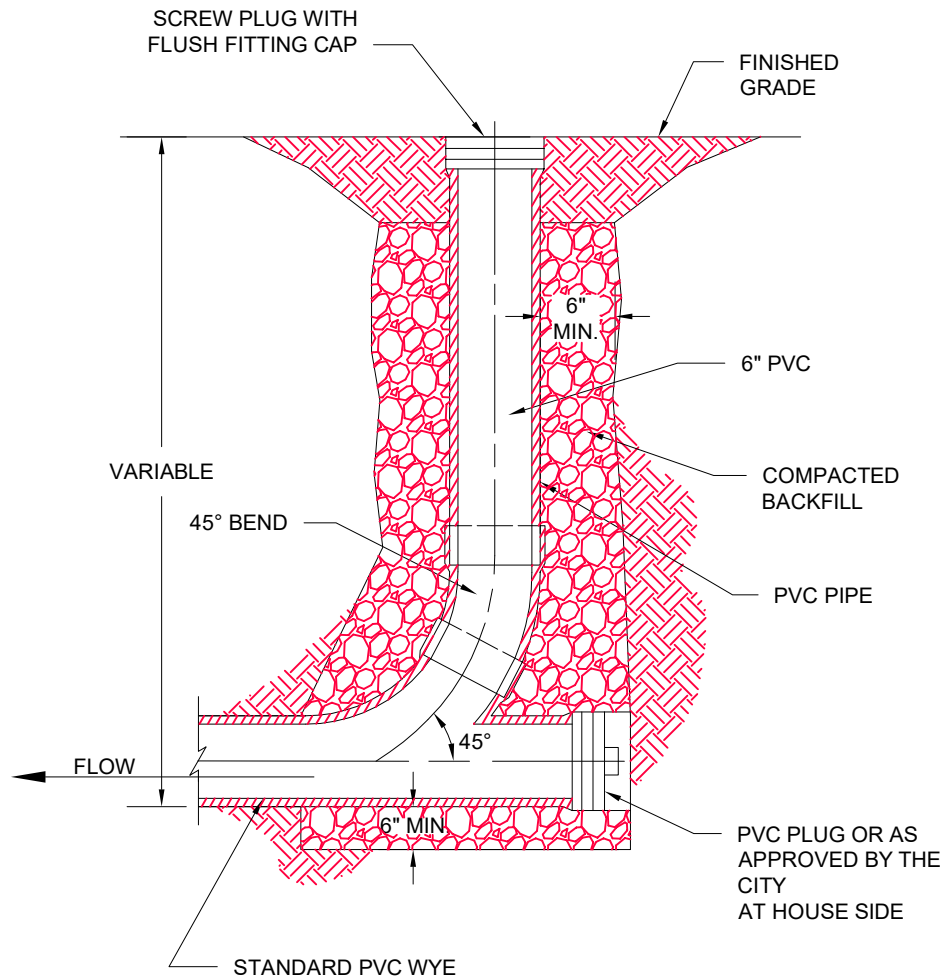

DEMOLITION ABANDONMENT

AT SANITARY LATERALS ONLY

CITY OF PIQUA

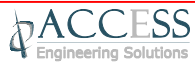

SANITARY SEWER DEMO ABANDONMENT

REVISIONS:
05-01-18 BG

DATE APPROVED:
DEC. 2016

PAGE No.
500-5

600 – Storm Drainage

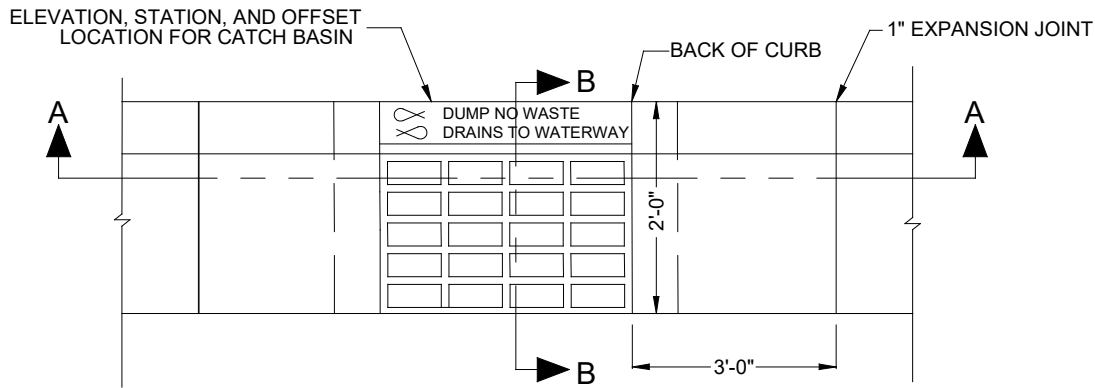

TOP VIEW

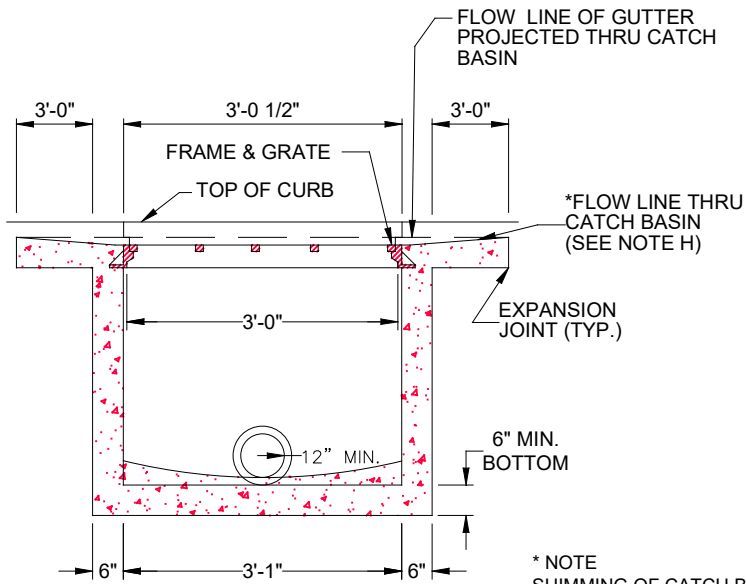

SECTION A-A

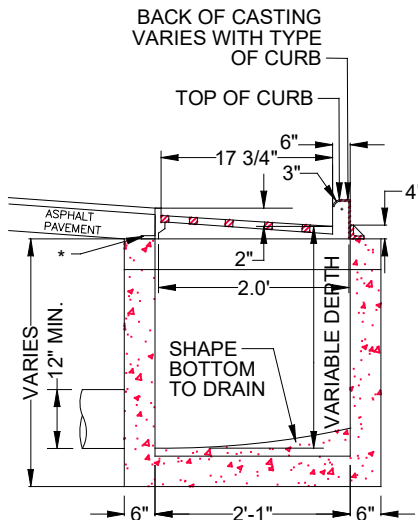

SECTION B-B

* NOTE
SHIMMING OF CATCH BASIN
FRAME MAY BE REQUIRED
TO KEEP LIP OF GUTTER
CONSISTENT.

NOTES

- A. AS OF JANUARY 1, 2003 THE FOLLOWING TEXT SHALL BE CAST INTO THE TOP OF THE GRATE: **“DUMP NO WASTE”** AND **“DRAINS TO WATERWAY”**.

TEXT SHALL BE PRINTED IN BOLD, CAPITAL LETTERS WITH A MINIMUM HEIGHT OF ½ INCH. “WATERWAY” MAY BE SUBSTITUTED WITH “STREAM”, “RIVER”, “LAKE”, ETC. ACTUAL PLACEMENT AND LOGO MAY VARY PER MANUFACTURER.
- B. CASTING SHALL BE EAST JORDAN 7030 OR NEENAH R-3246 OR EQUIVALENT.
- C. FOR TYPE 2 COMBINATION CURB AND GUTTER THE BACK SHALL BE EAST JORDAN TYPE T4, OR NEENAH (3 INCH RADIUS) (R-3246-1).
- D. FOR TYPE 1 COMBINATION ROLL CURB AND GUTTER THE BACK SHALL BE EAST JORDAN TYPE T2 OR NEENAH (MOUNTABLE CURB) (R-3246-E OR R-3067C).
- E. CATCH BASIN IN DRIVE APPROACHES TO BE AVOIDED, IF POSSIBLE. THE BACKS SHALL BE EAST JORDAN TYPE T3 OR NEENAH (R-3246-1 WITH CURB PLATE OR R3067C).
- F. STANDARD GRATE SHALL BE EAST JORDAN TYPE M2, NEENAH TYPE C, OR EQUIVALENT. ALL BAR EDGES TO BE ROUNDED 1/8 INCH RADIUS.
- G. CONCRETE, CAST-IN-PLACE, TO BE CLASS QC1. PRECAST CONSTRUCTION PERMITTED AND CONCRETE SHALL MEET THE REQUIREMENTS OF 706.13 WITH 7% ± 2% AIR VOID CONTENT IN THE HARDENED CONCRETE. KNOCKOUTS ARE REQUIRED IN PRECAST CONSTRUCTION. PRECAST WALLS SHALL HAVE A SUFFICIENT AMOUNT OF REINFORCEMENT TO PERMIT SHIPPING AND PLACEMENT WITHOUT DAMAGE.
- H. CARE SHALL BE TAKEN WHEN CONNECTING TO AN EXISTING CATCH BASIN TO KEEP OPENING AS MINIMAL AS POSSIBLE. IF POSSIBLE, SAW CUT OR USE ROTARY HAMMER FOR OPENING TO MINIMIZE DAMAGE TO CATCH BASIN. PIPE TO INTRUDE INTO CATCH BASIN 1 INCH ONLY AND PIPE MUST BE CUT PARALLEL TO CATCH BASIN. USE NON-SHRINK GROUT AROUND PIPE TO SEAL BETWEEN PIPE AND CATCH BASIN.
- I. DROP FLOW LINE ½ INCH WITHIN BLOCK OUT OF COMBINED CURB AND GUTTER WHILE KEEPING LIP OF GUTTER CONSISTENT WITH TOP OF CURB.
- J. ALL GRATES SHALL BE CONSIDERED “BICYCLE SAFE”.

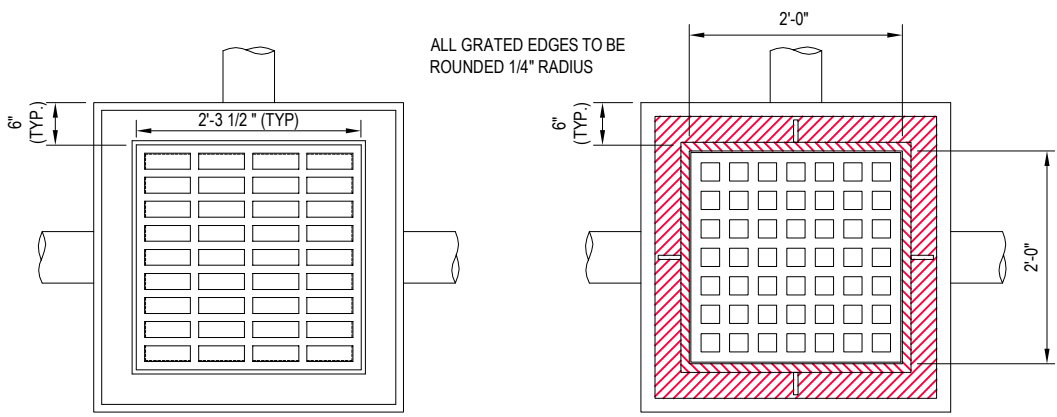

PLAN

PLAN

ALL GRATED EDGES TO BE
ROUNDED 1/4" RADIUS

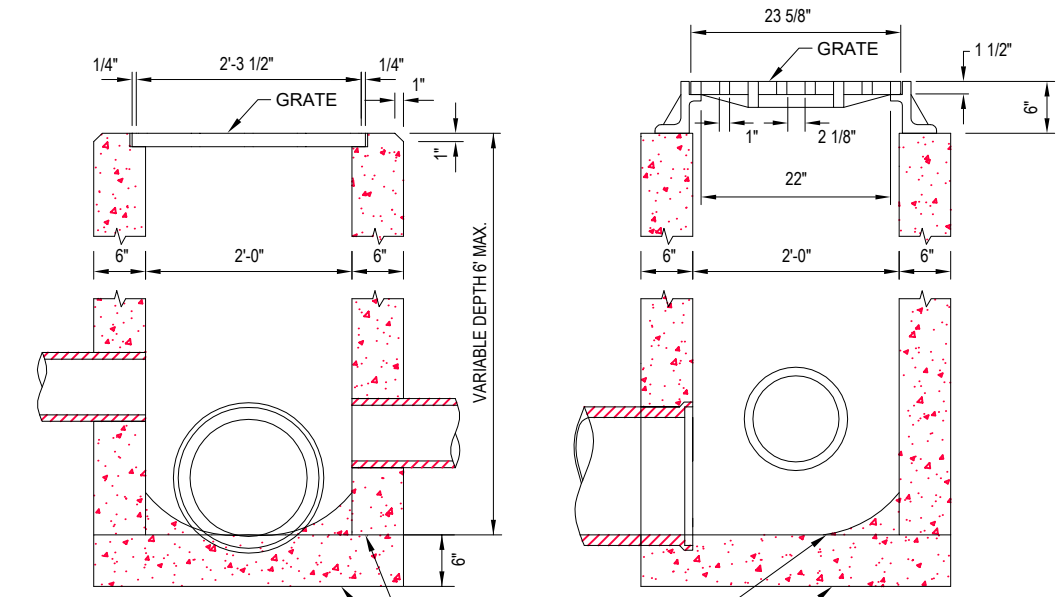

NONPAVED AREAS

PAVED AREAS

PERMISSIBLE CONSTRUCTION JOINT
BOTTOM SLAB MAY BE CAST SEPARATELY
AND THE OUTLET PIPE PLACED ON TOP OF
IT WITH THE BOTTOM SHAPED TO DRAIN.

NOTES

- A. AS OF JANUARY 1, 2003 THE FOLLOWING TEXT SHALL BE CAST INTO THE TOP OF THE GRATE:
 "DUMP NO WASTE" AND "DRAINS TO WATERWAY"
 TEXT SHALL BE PRINTED IN BOLD, CAPITAL LETTERS WITH A MINIMUM HEIGHT OF 1/2 INCH. "WATERWAY" MAY BE SUBSTITUTED WITH "STREAM", "RIVER", "LAKE", ETC. ACTUAL PLACEMENT AND LOGO MAY VARY PER MANUFACTURER.
- B. LOCATION AND ELEVATIONS WHEN GIVEN ON THE PLANS IS TOP CENTER OF THE GRATE. WHEN SIDE OPENINGS ARE PROVIDED. ELEVATION SHALL BE THE FLOW LINE OF THE SIDE INLET.
- C. GRATE FOR NON-PAVED AREAS SHALL BE EAST JORDAN IRON WORKS 5110 TYPE M3 OR NEENAH CATALOG NO. R-4859-C OR EQUIVALENT.
- D. GRATE ELEVATION TO BE PLACED 4 INCH TO 6 INCH BELOW NORMAL DITCH RETURNING TO NORMAL 10' EACH SIDE OF BASIN.
- E. PRECAST CONSTRUCTION IS REQUIRED, UNLESS OTHERWISE APPROVED AND CONCRETE SHALL MEET THE REQUIREMENTS OF 706.13 WITH 6±2% AIR VOID CONTENT IN THE HARDENED CONCRETE. KNOCKOUTS SHALL BE PROVIDED IN PRECAST CONSTRUCTION. PRECAST WALLS SHALL HAVE A SUFFICIENT AMOUNT OF REINFORCEMENT TO PERMIT SHIPPING AND PLACEMENT WITHOUT DAMAGE.
- F. CATCH BASINS NOT PERMITTED IN PAVEMENT AREAS UNLESS USING A FRAME AND GRATE EQUIVALENT OF NEENAH CATALOG NO. R-3405 OR EAST JORDAN IRON WORKS NO. 5250.
- G. FOR PIPES OVER 18" REFER TO ODOT CATCH BASIN 2-3 AND 2-4 FOR SIDE INLETS REFER TO ODOT CATCH BASIN 2-2-A.
- H. CARE SHALL BE TAKEN WHEN CONNECTING TO AN EXISTING CATCH BASIN TO KEEP OPENING AS MINIMAL AS POSSIBLE. IF POSSIBLE SAW CUT OR USE ROTARY HAMMER FOR OPENING TO MINIMIZE DAMAGE TO CATCH BASIN 1" ONLY AND PIPE MUST BE CUT PARALLEL TO CATCH BASIN. USE NON-SHRINK GROUT AROUND PIPE TO SEAL BETWEEN PIPE AND CATCH BASIN.

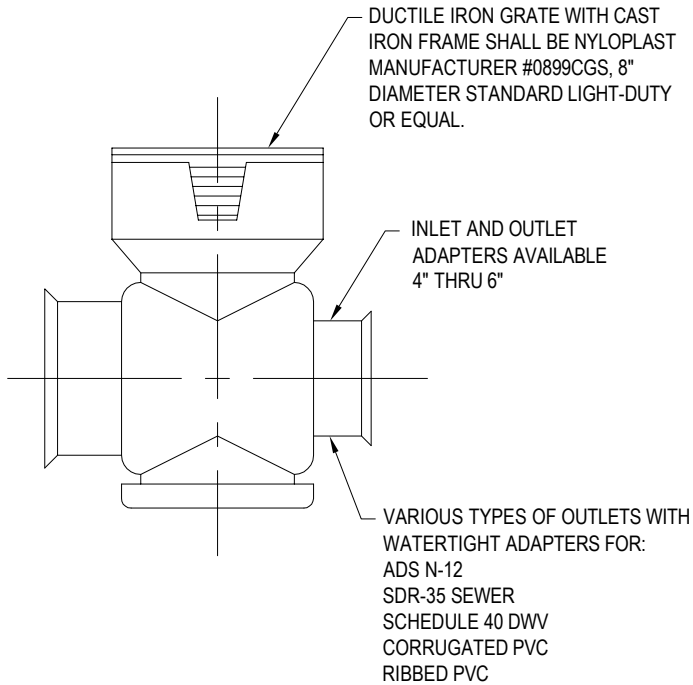

TYPE 2 YARD DRAIN

- STANDARD OR CUSTOM DRAIN BASIN FOR VARIABLE INLET HEIGHT SHALL BE NYLOPLAST MANUFACTURER #2808AG OR EQUAL.

- CONTRACTOR TO INSTALL PER MANUFACTURER'S RECOMMENDATIONS.

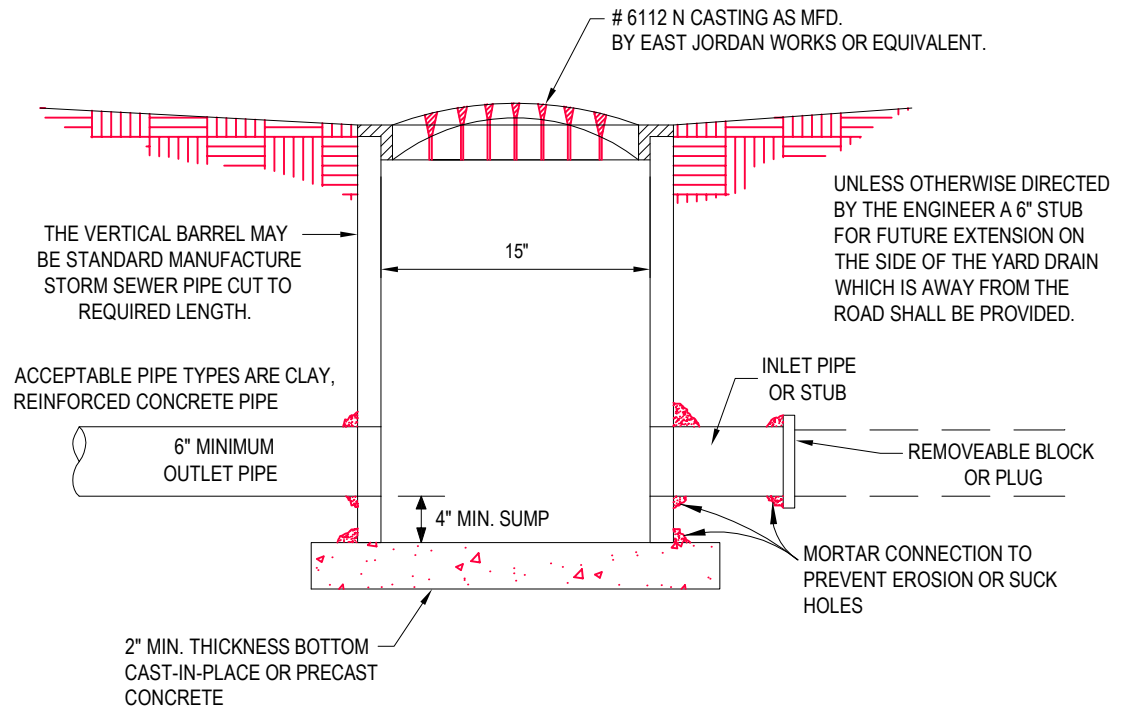

TYPE 3 YARD DRAIN

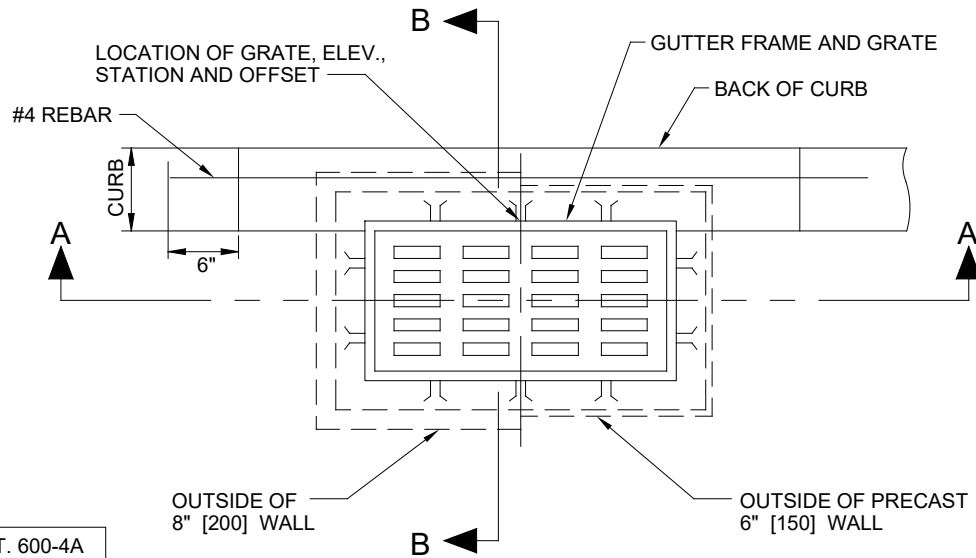

SEE SHT. 600-4A FOR SECTIONS

PLAN OF CATCH BASINS AND PAVEMENT JOINTS

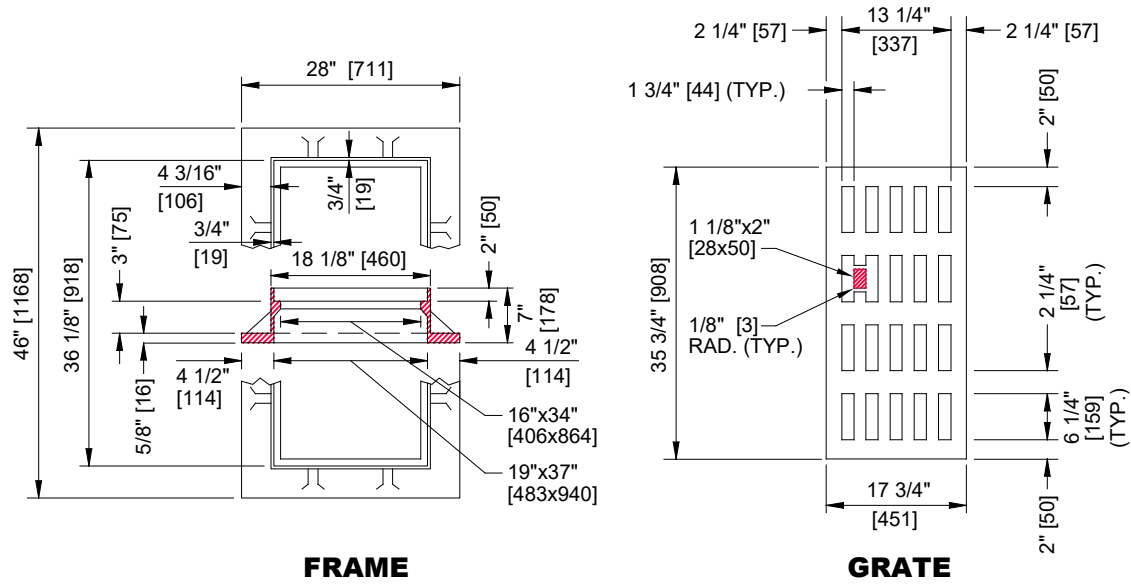

NOTES

- GRATE AND FRAME:** AS OF JANUARY 1, 2003 THE FOLLOWING TEXT SHALL BE CAST INTO THE TOP OF THE GRATE: **"DUMP NO WASTE"** AND **"DRAINS TO WATERWAY"**.
TEXT SHALL BE PRINTED IN BOLD, CAPITAL LETTERS WITH A MINIMUM HEIGHT OF 1/2 INCH. "WATERWAY" MAY BE SUBSTITUTED WITH "STREAM", "RIVER", "LAKE", ETC. ACTUAL PLACEMENT AND LOGO MAY VARY PER MANUFACTURER.
- THE DESIGN SHALL BE ESSENTIALLY THE SAME AND EQUALLY AS STRONG AS THE ONE SHOWN (SEE CONSTRUCTION INFORMATION TABLE), OR MEET THE REQUIREMENTS OF CMS 711.14. GRATE OPENINGS AND DIMENSIONS SHALL NOT DIFFER FROM THOSE SHOWN HERE UNLESS OTHERWISE SHOWN IN THE PLANS.
- BEARING AREAS:** THE FRAME AND GRATE SHALL BE SO FITTED AND FINISHED AS TO PROVIDE A FIRM AND EVEN SEAT FOR ALL PORTIONS OF THE GRATE IN THE FRAME. NO PROJECTIONS SHALL EXIST ON BEARING AREAS OF WITHER CASTING AND THE GRATE SHALL SEAT IN ITS FRAME WITHOUT ROCKING. THE FRAME AND GRATE SHALL BE FITTED, MATCHED, AND MARKED BEFORE DELIVERY TO THE PROJECT.
- WALLS:** BRICK OR CAST-IN-PLACE WALLS SHALL HAVE A NOMINAL THICKNESS OF 8" (200). PRECAST WALLS SHALL HAVE A MINIMUM THICKNESS OF 6" (150) AND BE REINFORCED AND SUFFICIENTLY TO PERMIT SHIPPING AND HANDLING WITHOUT DAMAGE.
- CONCRETE:** CAST-IN-PLACE CONCRETE SHALL BE ODOT CLASS QC1. PRECAST CONCRETE SHALL MEET THE REQUIREMENTS OF CMS 706.13 AND BE MARKED WITH THE CATCH BASIN NUMBER. THE WALL THICKNESS REDUCTION SHALL BE FROM THE OUTSIDE.
- MINIMUM DEPTH:** THE MINIMUM DEPTH SHALL BE THE OUTSIDE DIAMETER (O.D.) OF THE OUTLET PIPE PLUS 15" (380).
- OPENINGS:** PIPE OPENINGS SHALL BE THE O.D. OF THE PIPE BEING SUPPLIED PLUS 2" (50) WHEN FABRICATED OR FIELD CUT. FILL ANY VOIDS PER CMS 601.

CITY OF PIQUA



TYPE 6 CATCH BASIN

REVISIONS:
12-19-16 BG
12-31-20 KK

DATE APPROVED:
DEC. 2016

PAGE No.
600-4

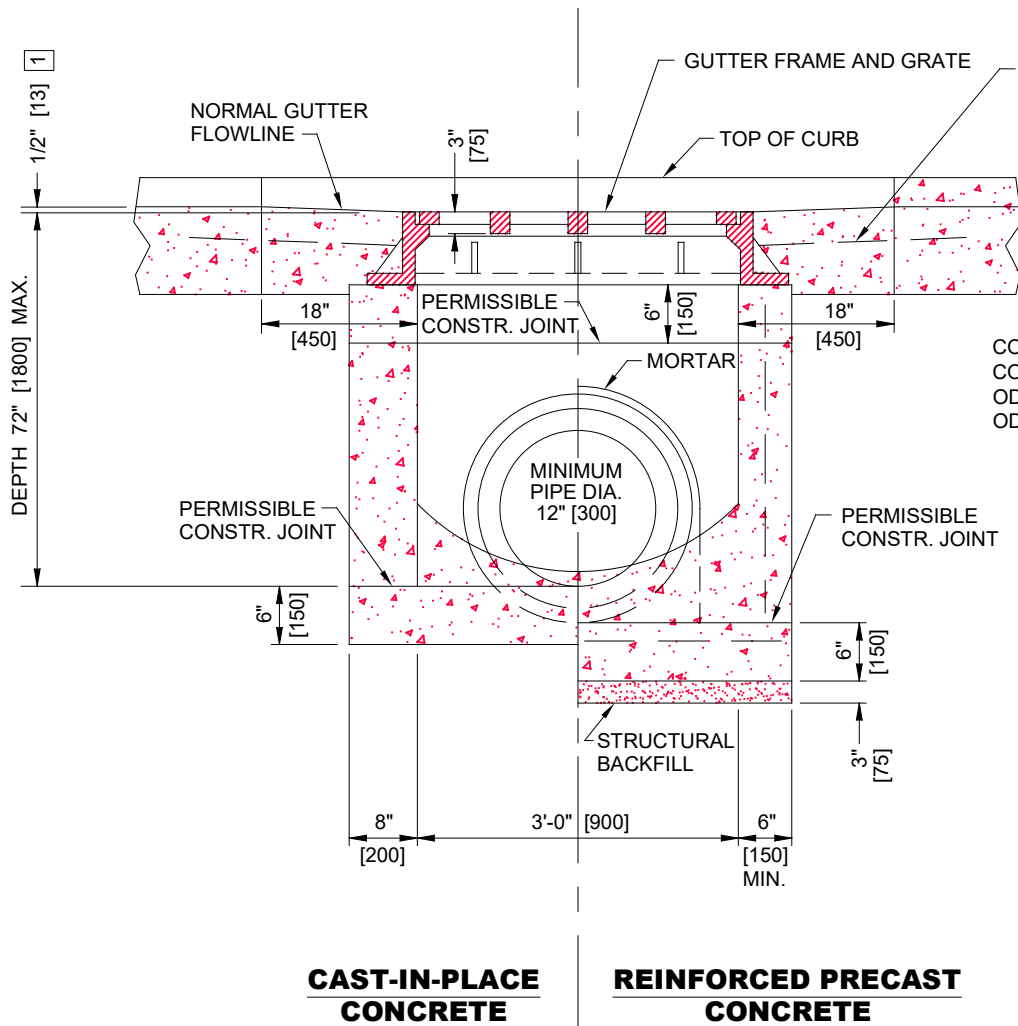

SECTION A-A
(SEE SHEET 600-4)

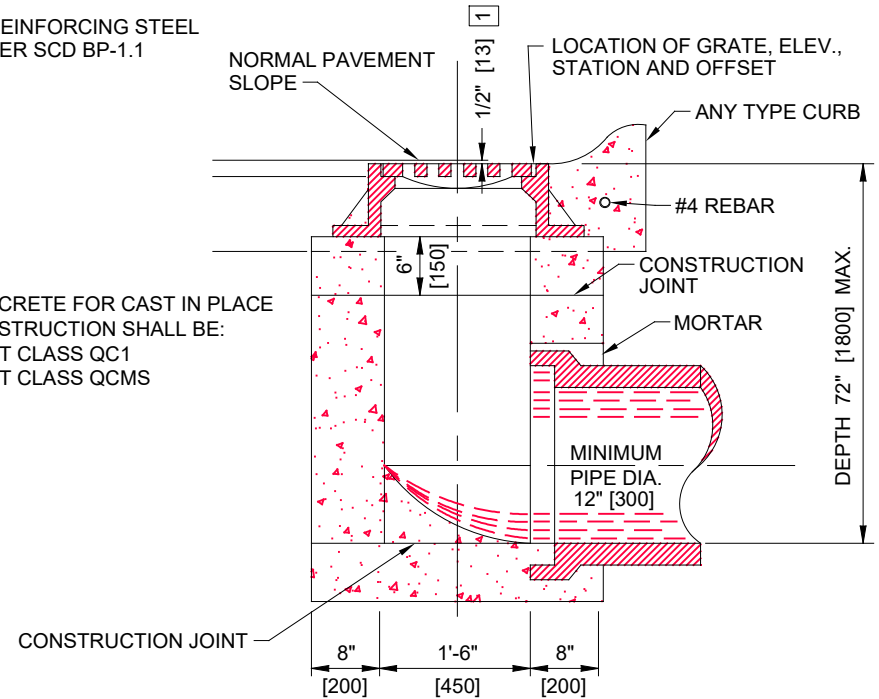

SHOWN WITH CAST-IN-PLACE WALLS

SECTION B-B
(SEE SHEET 600-4)

CITY OF PIQUA



TYPE 6 CATCH BASIN

REVISIONS:
12-19-16 BG
12-31-20 KK

DATE APPROVED:
DEC. 2016

PAGE No.
600-4A

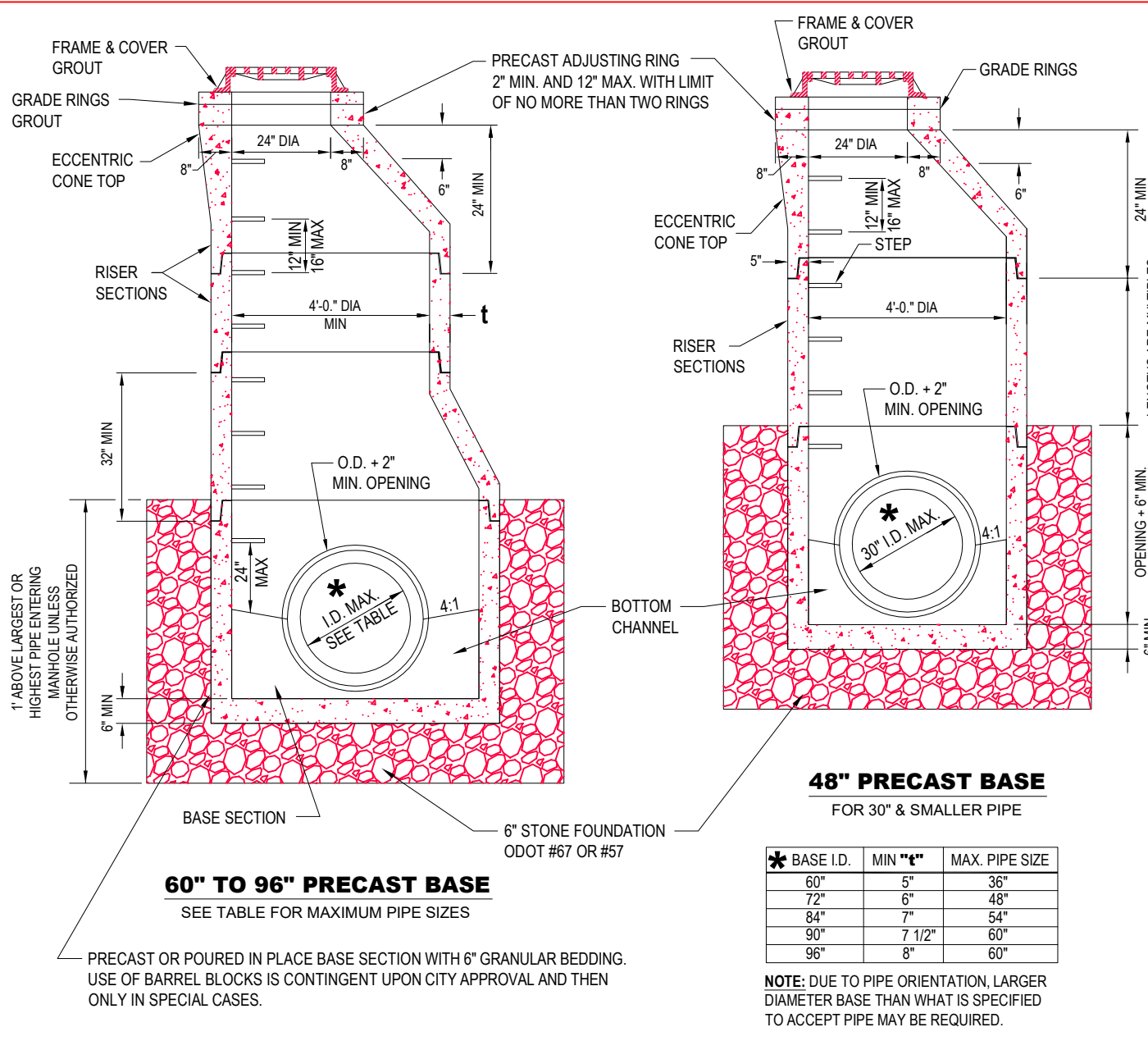

- NOTES**
- A. STORM MANHOLE FRAME AND APPROVED VENTED LID SHALL BE EQUAL OF NEENAH NO. R-1767 OR EAST JORDON IRON WORKS NO 1600.
 - B. TOP AND TRANSITION (OR REDUCER) SECTIONS MY BE EITHER ECCENTRIC CONE OR FLAT SLAB.
 - C. OPENINGS IN RISER SECTIONS FOR 18 INCH AND SMALLER INLET PIPES MAY BE PREFABRICATED OR CUT IN THE FIELD PROVIDED THE SIDES OF THE PIPE AT THE SPRING LINE DO NOT PROJECT INTO THE MANHOLE.
 - D. MATERIALS FOR BASES AND OTHER PRECAST SECTIONS, INCLUDING REINFORCEMENT SHALL COMPLY WITH ODOT REQUIREMENTS OF 706.13 (ASTM C-478).
 - E. LOCATE THE CENTERLINE OF MANHOLE CONES OVER THE CENTERLINE OF THE MAIN SEWER WHENEVER POSSIBLE.
 - F. FOR PIPE SIZES LARGER THAN 60 INCHED REFER TO ODOT TYPE 4 TO 5 MANHOLE.
 - G. NO LATERALS MAY PROTRUDE INTO INTERNAL MANHOLE.
 - H. MAXIMUM SPACING SHALL BE 400 FEET.
 - I. WHEN CONNECTING TO AN EXISTING STORM MANHOLE CARE SHALL BE TAKEN TO KEEP OPENING AS MINIMAL AS POSSIBLE. IF POSSIBLE, SAW CUT OR USE ROTARY HAMMER FOR OPENING TO MINIMIZE DAMAGE TO STORM MANHOLE AND PIPE MUST BE CUT PARALLEL TO STORM MANHOLE. USE NON-SHRINK GROUT AROUND PIPE TO SEAL BETWEEN PIPE AND STORM MANHOLE.
 - J. JOINTS BETWEEN SECTIONS TO BE EITHER MORTAR OR BITUMINOUS PIPE JOINT FILLER (ODOT 706.10)

TYPE 3 STORM MANHOLE

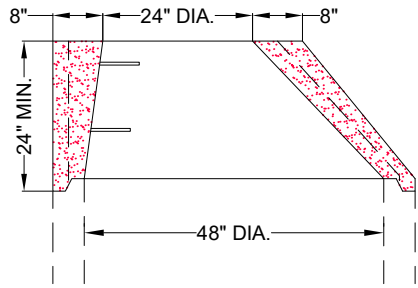

ECCENTRIC CONE TOP

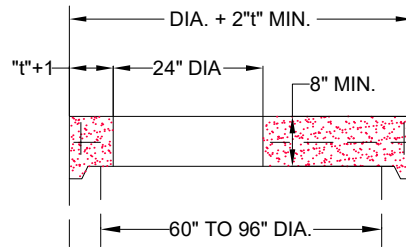

FLAT SLAB TOP

BASE I.D.	MIN. "t"	MAX. PIPE SIZE
60"	5"	36"
72"	6"	48"
84"	7"	54"
90"	7 1/2"	60"
96"	8"	60"

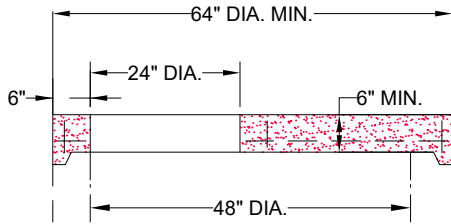

FLAT SLAB TOP

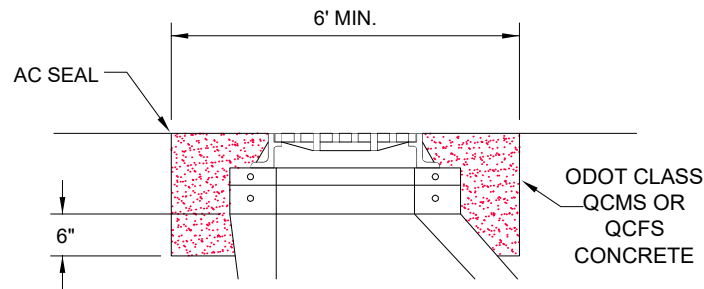

MANHOLE REPAIR CASTING CONSTRUCTION

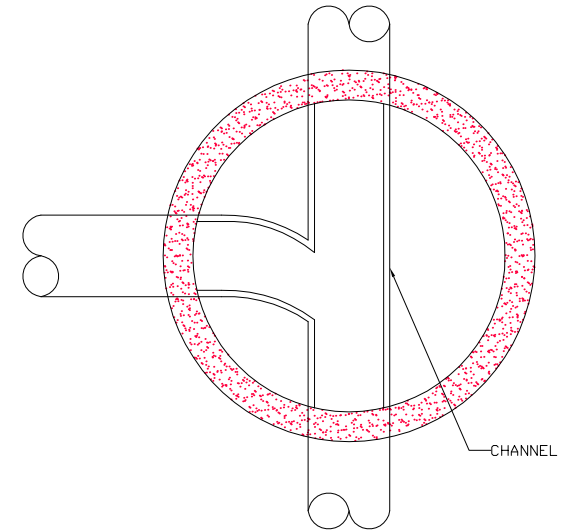

SECTIONAL PLAN

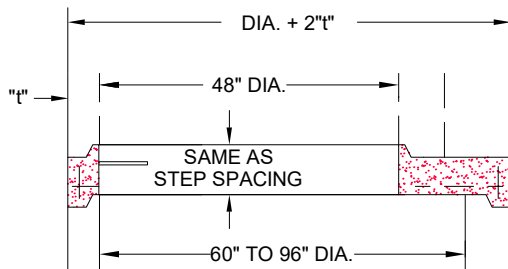

FLAT SLAB TRANSITION

NOTES:

1. PRECAST CONCRETE ADJUSTING RINGS - ENCASE WITH CONCRETE 6" DOWN FROM BARREL TOP AND UP TO THE PAVEMENT SURFACE.

2. SET MANHOLE, PRECAST ADJUSTING RINGS AND CASTING. PAVE OVER MANHOLE. EXCAVATE CASTING AND COLLARS AND ENCASE COLLARS AND CASTINGS PER DETAIL.

NOTE:
ALL INVERTS TO BE CHANNELLED FOR OPTIMUM FLOW.

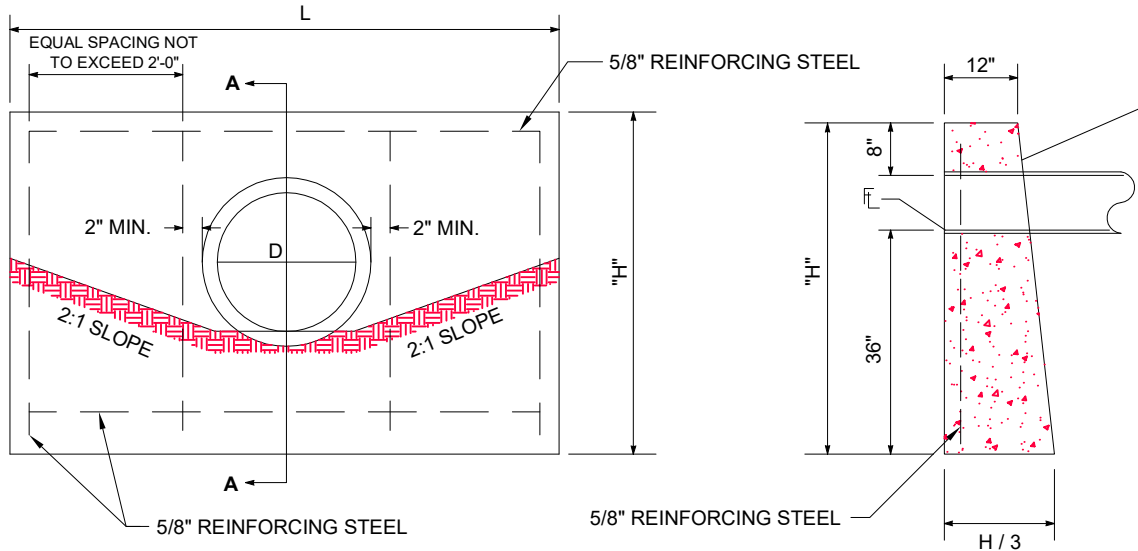

ELEVATION

SECTION A-A

INLET END
GROOVE OR BELL
UPSTREAM

OUTLET END
TONGUE OR SPIGOT
DOWNSTREAM

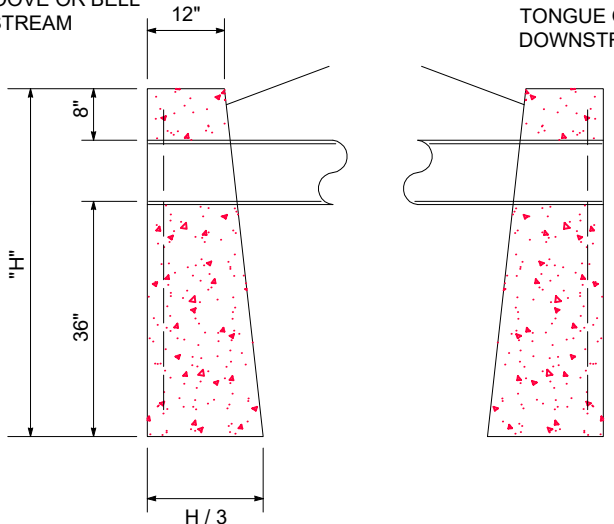

RIGID PIPE

- L. CIRCULAR SECTIONS = $5D + 4T$
- L. ELLIPTICAL OR PIPE -ARCH = $4R + 4T + S$
- H CIRCULAR SECTIONS = $D + T + 44"$
- H ELLIPTICAL OR PIPE -ARCH = $R + T + 44"$
- D= DIAMETER OF PIPE
- S= SPAN OF PIPE
- L= LENGTH OF HEADWALL
- R= RISE OF PIPE
- T= THICKNESS OF BARREL
- H= HEIGHT OF HEADWALL.

NOTES

- A. THESE FULL HEIGHT HEADWALLS ARE FOR NON-SKEWED CULVERTS HAVING A DIAMETER OR RISE OF 36 INCHES OR LESS
- B. CONCRETE SHALL BE ODOT QCI CONCRETE. REINFORCED STEEL BAR SHALL BE 5/8 INCH ROUND
- C. DIMENSIONS AND QUANTITIES ARE SHOWN FOR CIRCULAR SECTIONS ONLY. IT WILL BE NECESSARY TO DETERMINE DIMENSIONS FOR THE HW-1 HEADWALL REQUIRED FOR REINFORCED ELLIPTICAL CONCRETE PIPE OR CORRUGATED METAL PIPE ARCHES IN ACCORDANCE WITH EQUATIONS LISTED ON THIS DRAWING.
- D. CHAMFER ALL EXPOSED CORNERS $\frac{3}{4}$ INCH.
- E. WHERE THE SOIL BORINGS INDICATE A BEARING CAPACITY 0 LESS THAN 2600 LBS. PER SQUARE FOOT, IT WILL BE NECESSARY TO INCREASE THE WIDTH OF THE BASE.
- F. MINIMUM COVER FOR REINFORCING STEEL SHALL BE 2 INCH.
- G. FOR PIPES HAVING A DIAMETER OR RISE OVER 36 INCHES, REFERENCE ODOT HW-3 HEADWALLS FOR FULL HEIGHT HEADWALL.
- H. FOR SKEWED CULVERTS HAVING A DIAMETER OR RISE OF 36 INCHES OR LESS, REFERENCE ODOT HW-2 HEADWALLS.
- I. HEADWALLS MAY BE PRECAST CONCRETE CONSTRUCTED TO THE ABOVE REQUIREMENTS. GROUT AROUND PIPE AFTER INSTALLATION.

DIMENSIONS			QUANTITIES ONE HEADWALL	
DIAMETER	HIEGHT	LENGTH	CONCRETE CY.	REINFORCING STEEEL LBS
15"	5'-2"	7'-0"	1.7	41
18"	5'-5"	8'-4"	2.2	57
21"	5'-8"	9'-8"	2.8	62
24"	5'-11"	11'-0"	3.3	69
30"	6'-5"	13'-8"	4.7	92
36"	7'-0"	16'-4"	6.5	105

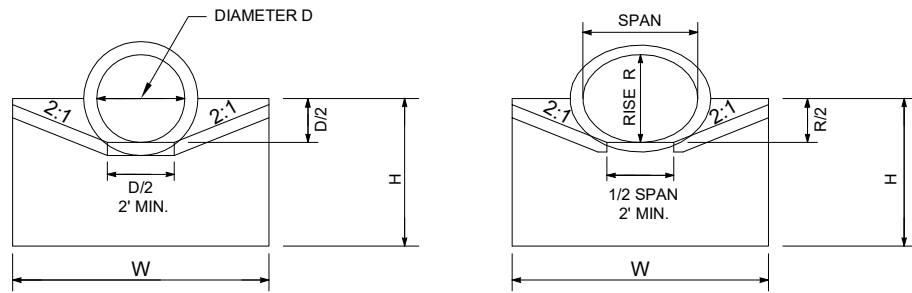

CIRCULAR

ELLIPTICAL

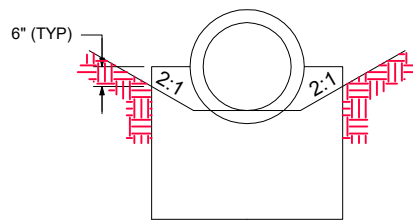

WIDTH OF PROTECTION SHALL EQUAL WIDTH OF HEADWALL. MINIMUM WIDTH 4'-0"

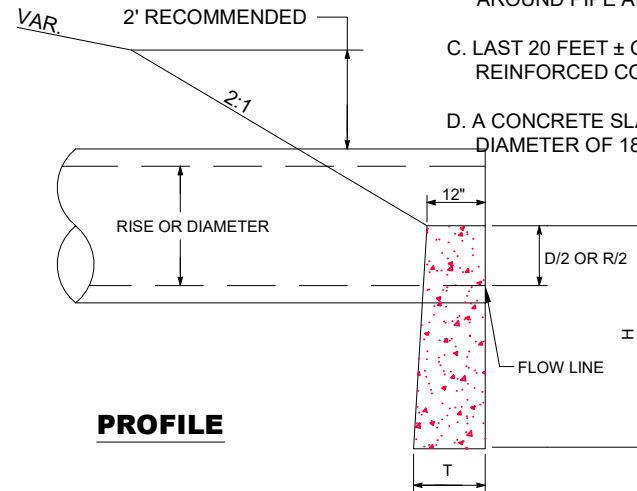

PROFILE

NOTES

- A. CONCRETE FOR HEADWALLS SHALL BE ODOT CLASS C. CONCRETE QUANTITIES ARE BASED ON HEADWALLS ONLY.
- B. HEADWALLS MAY BE PRECAST CONCRETE CONSTRUCTED TO THE ABOVE REQUIREMENTS. GROUT AROUND PIPE AFTER INSTALLATION.
- C. LAST 20 FEET ± OF PIPE BEFORE HEADWALL SHALL BE REINFORCED CONCRETE PIPE.
- D. A CONCRETE SLAB IS REQUIRED FOR PIPES WITH A DIAMETER OF 18 INCH AND ABOVE.

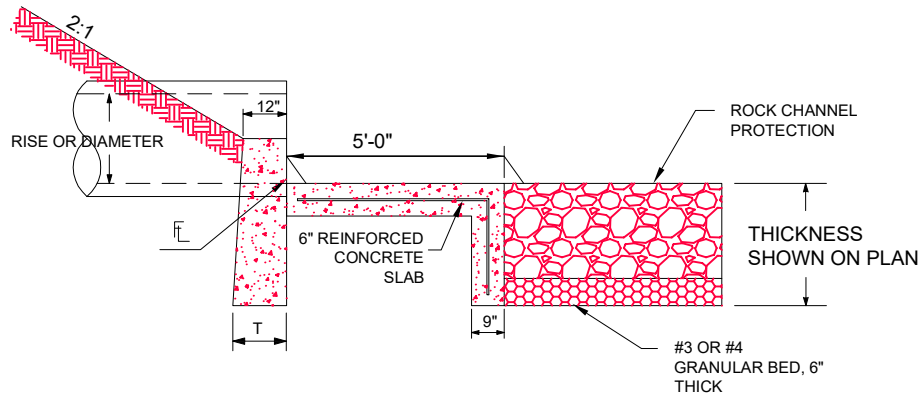

OUTLET CHANNEL PROTECTION DETAIL

(CUTOFF WALL DEPTH 2'-6" MINIMUM IS VARIABLE TO MATCH REQUIRED THICKNESS OF ROCK.)

HEAD WALL FOR CONCRETE PIPE										
CIRCULAR				CONC. S.Y.	ELLIPTICAL					CONC. S.Y.
D	W	H	T		SPAN	RISE	W	H	T	
12"	2'-0"	3'-0"	12"	.20	23"	14"	3'-0"	3'-2"	12"	.29
15"	2'-6"	3'-2"	12"	.25	30"	19"	3'-7"	3'-4"	12"	.35
18"	3'-0"	3'-3"	12"	.31	34"	22"	3'-11"	3'-5"	12"	.38
21"	3'-6"	3'-4"	12"	.37	38"	24"	4'-6"	3'-6"	12"	.44
24"	4'-0"	3'-6"	12"	.43	42"	27"	4'-8"	3'-7"	12"	.45
27"	4'-6"	3'-8"	12"	.49	45"	29"	5'-2"	3'-8"	12"	.49
30"	5'-0"	3'-9"	12"	.56	49"	32"	5'-5"	3'-10"	12"	.52
33"	5'-6"	3'-10"	12"	.62	53"	34"	5'-11"	4'-0"	14"	.66
36"	6'-0"	4'-0"	12"	.69	60"	38"	6'-10"	4'-2"	14"	.82
39"	6'-6"	4'-2"	12"	.77	68"	43"	8'-0"	4'-4"	16"	1.01
42"	7'-0"	4'-3"	12"	.84	76"	48"	9'-2"	5'-0"	16"	1.34
48"	8'-0"	4'-6"	14"	1.09	83"	53"	10'-4"	5'-2"	18"	1.65
54"	9'-3"	4'-9"	14"	1.32	91"	58"	11'-6"	5'-5"	18"	1.97
60"	10'-6"	5'-6"	16"	1.93	98"	63"	12'-7"	5'-7"	20"	2.38
66"	11'-9"	5'-9"	18"	2.42	106"	68"	13'-9"	5'-10"	20"	2.69
72"	13'-0"	6'-0"	18"	2.77	113"	72"	14'-9"	6'-0"	22"	3.14
78"	14'-3"	6'-3"	20"	3.37	121"	77"	15'-11"	6'-3"	22"	3.49
84"	15'-6"	6'-6"	22"	4.05	128"	82"	17'-0"	6'-5"	24"	4.04

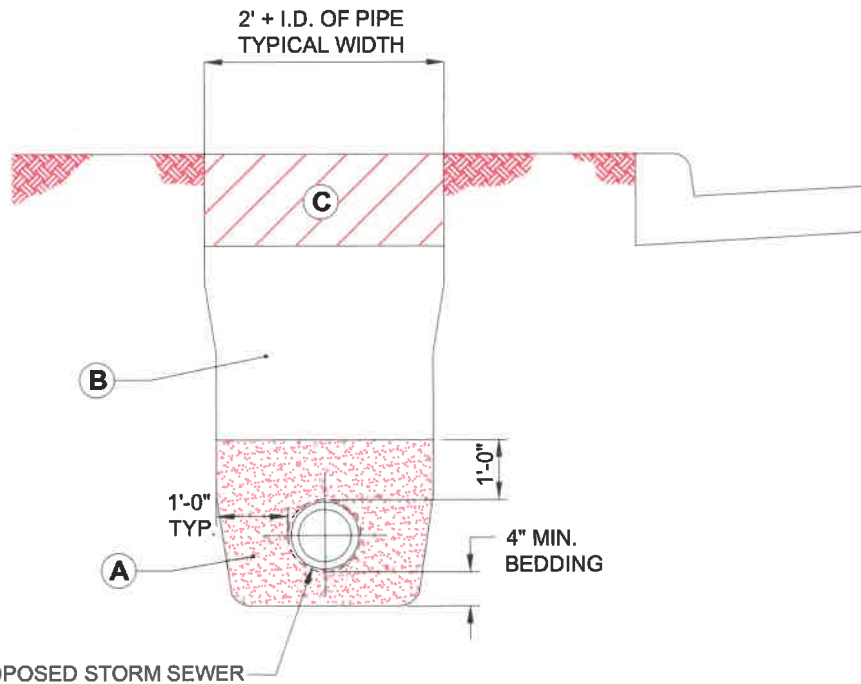

STORM SEWER TRENCH DETAIL

(NON-RIGID PIPE)

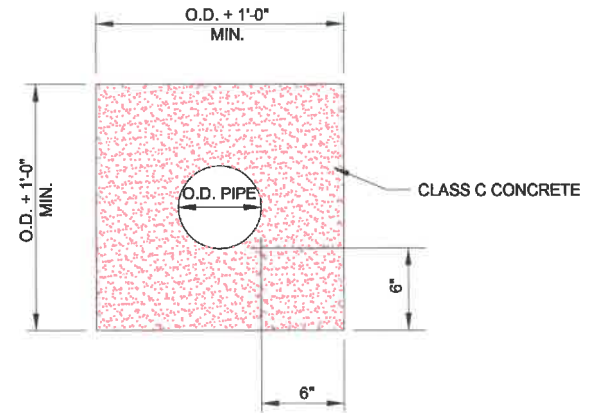

CONCRETE ENCASEMENT DETAIL

TRENCH DETAIL NOTES

- A. GRANULAR BEDDING SHALL BE CRUSHED STONE OR GRAVEL ODOT 603 TYPE 3 (#57 OR #67), OR OTHER APPROVED EQUIVALENT.
 - B. ALL TRENCHES OUTSIDE THE RIGHT-OF-WAY FROM PROPOSED OR EXISTING PAVEMENT, CURB, DRIVEWAY, ALLEYS, STONE AREAS OR WALKS CAN BE COMPACTED WITH EXISTING NATIVE MATERIAL IN 12 INCH MAXIMUM LIFTS OR AS APPROVED BY THE CITY. NO MATERIAL SHALL BE USED FOR BACK FILLING THAT CONTAINS STONE, ROCKS, ETC. GREATER THAN 4 INCH DIAMETER.
- ALL TRENCHES INSIDE THE RIGHT-OF-WAY FROM PROPOSED OR EXISTING PAVEMENT, CURB DRIVEWAYS, ALLEYS, STONE AREAS OR WALKS SHALL BE COMPACTED WITH GRANULAR BACKFILL MATERIAL ODOT 603 TYPE 1 IN 6" MAXIMUM LIFTS.

A DENSITY TEST ON GRANULAR BACKFILL OF 98% OF ASTM D698 STANDARD PROCTOR CURVE MAY BE REQUIRED TO BE PERFORMED BY A COMMERCIAL TESTING LAB SATISFACTORY TO THE CITY.

- C. OFF-PAVEMENT AREAS SHALL BE PROVIDED WITH A MINIMUM OF 6 INCH OF TOPSOIL OVER THE COMPACTED MATERIAL AND THEN SEED AND MULCHED PER ODOT ITEM 659.

ALL PAVED AREAS WITHIN THE STREET RIGHTY-OF-WAY SHALL FOLLOW THE REQUIREMENTS FO PAGE 300-14 OF THE STANDARD DRAWINGS.

- D. THE OPEN ENDS OF ALL PIPES SHALL BE PLUGGED TO THE APPROVAL OF THE CITY BEFORE LEAVING THE WORK FOR THE NIGHT.

NOTES:

- A. NO WORK SHALL BE APPROVED OR ACCEPTED BY THE CITY UNLESS 2 WORKING DAYS NOTICE OF COMMENCING WORK IS GIVEN TO THE CITY.
- B. ALL TEMPORARY PAVEMENT AND SIDEWALK SHALL BE MAINTAINED BY THE CONTRACTOR OR THE DEVELOPER AT HIS OWN EXPENSE IN A SUITABLE AND SAFE CONDITION FOR TRAFFIC UNTIL A PERMANENT REPLACEMENT IS MADE OR THE PROJECT IS FINALLY ACCEPTED BY THE CITY.
- C. ALL STORM SEWER CONSTRUCTION SHALL ADHERE TO ODOT SPECIFICATIONS LATEST REVISION OR WITH THE CITY STORM SEWER SPECIFICATIONS, WHICHEVER IS APPLICABLE AND MORE RESTRICTIVE.
- D. MASTIC MATERIAL IS REQUIRED ON ALL NON O-RING STORM SEWER AND MANHOLES, UNLESS OTHERWISE APPROVED.
- E. WHEN A CASTING IS REMOVED IT REMAINS CITY PROPERTY AND TO BE DELIVERED TO THE CITY SERVICE CENTER, UNLESS OTHERWISE APPROVED.
- F. ANY DETAILS OR NOTES NOT DIRECTLY ADDRESSED IN THESE ENGINEERING STANDARDS SHALL BE COORDINATED WITH THE CITY ENGINEERING DEPARTMENT.
- G. ALL STORM SEWER SHALL BE INSTALLED USING PIPE LASER INSIDE THE PIPE IF POSSIBLE FOR GRADE AND ALIGNMENT.

UTILITY STAKING

- A. OFFSET AND GRADE AT EACH MANHOLE, CATCH BASIN, AND OTHER STRUCTURES. OFFSET AND GRADE 50 FEET AND 100 FEET OUT FROM EACH MANHOLE UNLESS OTHERWISE APPROVED.

PIPE

- A. ALL STORM SEWER PIPE SHALL HAVE A MINIMUM DIAMETER OF 12 INCH UNLESS OTHERWISE APPROVED.
- B. TYPES OF PIPE PERMITTED

APPROVED PIPE

ODOT MATERIAL NUMBER

REINFORCED CONCRETE PIPE	706.02
REINFORCED CONCRETE ELLIPTICAL PIPE	706.04
CORRUGATED POLYETHYLENE SMOOTH-LINED PIPE	707.33
POLYVINYL CHLORIDE PLASTIC PIPE (NON-PERFORATED)	707.41
POLYVINYL CHLORIDE CORRUGATED SMOOTH-INTERIOR PIPE	707.42
POLYVINYL CHLORIDE PROFILE WALL PIPE	707.43
POLYVINYL CHLORIDE SOLID WALL PIPE	707.45

EXISTING TILE HOOKUPS

- A. THE DRAINAGE TILE CURRENTLY CONNECTED TO THE EXISTING STORM SEWER SHALL BE CONNECTED TO THE PROPOSED STORM SEWER. ANY DRAINAGE TILE DAMAGED BY THE CONTRACTOR SHALL BE REPLACED BY THE CONTRACTOR TO A CONDITION EQUAL TO OR BETTER THAN ITS ORIGINAL CONDITION. ANYTHING REMOVED, REPLACED, AND/OR CONNECTED TO THE STORM SEWER SHALL BE NOTED ON THE AS-BUILT DRAWINGS AND SHALL BE INSPECTED BY THE INSPECTOR BEFORE THEY ARE COVERED.
- B. ALL FIELD OR STORM DRAINS WHICH ARE ENCOUNTERED DURING CONSTRUCTION SHALL BE PROVIDED WITH UNOBSTRUCTED OUTLETS OR PLUGGED AS APPROVED AND DIRECTED BY THE CITY

NOTES

- A. TEMPORARY EROSION AND SEDIMENT CONTROL MEASURES SHALL BE PROVIDED FOR ALL CONSTRUCTION PROJECTS HAVING SIGNIFICANT GRADING. THE CONTROLS ARE PROVIDED DURING CONSTRUCTION TO PREVENT SOIL ERODED FROM THE CONSTRUCTION AREA FROM ENTERING ADJACENT WATERWAYS AND PROPERTIES.
- B. CONSTRUCTION ITEMS INCLUDE SEDIMENT BASINS, SEDIMENT DAMS, DIVERSION DIKES AND/OR DITCHES AND STRAW BALES OR OTHER FILTER DIKES SHOWN ON ODOT STANDARD DRAWING MC-11. OTHER MISCELLANEOUS EROSION CONTROL MEASURES INCLUDE REPAIR SEEDING AND MULCHING, COMMERCIAL FERTILIZER, WATER AND MOWING AND ROCK CHANNEL PROTECTION, COVERED IN ODOT SPECIFICATION ITEMS 659 AND 601.
- C. THE SIZE OF THE ENTIRE DRAINAGE AREA CONTRIBUTING FLOW IS USED TO DETERMINE THE MOST EFFECTIVE EROSION CONTROL METHOD. IN MANY CASES THE MAJOR PORTION OF THE CONTRIBUTING AREA WILL BE BEYOND THE PROJECT LIMITS, AND FOR THOSE CASES IT WILL BE NECESSARY TO CONTROL THE FLOW FROM OUTSIDE BEFORE IT REACHES THE AREA DISTURBED BY PROJECT CONSTRUCTION. FLOW FROM THE AREA DISTURBED BY CONSTRUCTION SHALL BE TREATED PRIOR TO COMBINING IT WITH OFF-PAVEMENT DRAINAGE.
- D. EROSION AND SEDIMENT CONTROL MEASURES SHALL BE PROVIDED FOR ALL SUBDIVISIONS AND INDIVIDUAL SITES UNLESS OTHERWISE APPROVED. THE CONTROL MEASURES ARE TO BE PROVIDED DURING CONSTRUCTION TO PREVENT EROSION FROM ENTERING ADJACENT WATERWAYS AND PROPERTIES.
- E. THERE SHALL BE ONLY ONE CONSTRUCTION ENTRANCE OFF THE SITE. ENTRANCE TO BE CONSTRUCTED OF 8" OF #2 STONE, 75 FEET LONG BY 20 FEET WIDE. CONTRACTOR TO KEEP MUD OFF EXISTING STREETS. NO EQUIPMENT TO BE PARKED ON EXISTING STREETS. MORE THAN ONE ENTRANCE MUST BE APPROVED BY THE CITY.

PLAN SUBMITTAL

- A. ALL SITE PLANS SHALL INCLUDE APPROPRIATE EROSION AND SEDIMENT CONTROL DEVICES AND SHALL BE SUBMITTED TO THE CITY FOR APPROVAL PRIOR TO COMMENCEMENT OF ANY WORK UNLESS OTHERWISE APPROVED. ALL PROJECTS WHICH DISTURB 1 ACRE OR MORE MUST HAVE OEPA EROSION CONTROL APPROVALS.

CONSTRUCTION

- A. ALL EROSION AND SEDIMENT CONTROL MUST BE INSPECTED AND APPROVED BY THE CITY UNLESS OTHERWISE APPROVED.

STORM WATER PERMITS

- A. ON ALL PROJECTS WHICH DISTURB AT LEAST 1 ACRE OF SOIL, A NPDES PERMIT IS REQUIRED FROM OEPA AND A COPY OF THE PERMIT MUST BE ON FILE AT THE CITY BEFORE CONSTRUCTION BEGINS.
- B. EROSION CONTROL SUBMITTALS SHALL BE AS PER THE CURRENT STORM WATER MANAGEMENT ORDINANCE.

CONTROL MEASURES

- A. DISTURB ONLY THE AREAS NEEDED FOR CONSTRUCTION.
- B. REMOVE ONLY THOSE TREES, SHRUBS, AND GRASSES THAT MUST BE REMOVED FOR CONSTRUCTION; PROTECT THE REST TO PRESERVE THEIR ESTHETIC AND EROSION-CONTROL VALUES.
- C. INSTALL SEDIMENT BASINS AND DIVERSION DIKES BEFORE DISTURBING THE LAND THAT DRAINS INTO THEM.
- D. INSTALL EROSION AND SEDIMENT CONTROL PRACTICES AS INDICATED IN THE PLAN. THE PRACTICES ARE TO BE MAINTAINED IN EFFECTIVE WORKING CONDITION DURING CONSTRUCTION AND UNTIL THE DRAINAGE AREAS HAVE BEEN PERMANENTLY STABILIZED.
- E. TEMPORARILY STABILIZE EACH SEGMENT, GRADED OR OTHERWISE DISTURBED LAND, INCLUDING THE SEDIMENT-CONTROL DEVICES NOT OTHERWISE STABILIZED, BY SEEDING AND MULCHING OR BY MULCHING ALONE. AS CONSTRUCTION IS COMPLETED, PERMANENTLY STABILIZE EACH SEGMENT WITH PERENNIAL VEGETATION STRUCTURAL MEASURES.

- F. LEVEL DIVERSION DIKES, SEDIMENT BASINS, AND SILT TRAPS AFTER AREAS THAT DRAIN INTO THEM ARE STABILIZED. ESTABLISH PERMANENT VEGETATION ON THOSE AREAS. SEDIMENT BASINS THAT ARE TO BE RETAINED FOR STORM WATER DETENTION MAY BE SEEDED TO PERMANENT VEGETATION AFTER THEY ARE BUILT.

- G. DISCHARGE WATER FROM OUTLET STRUCTURES AT NON-EROSIVE VELOCITIES.

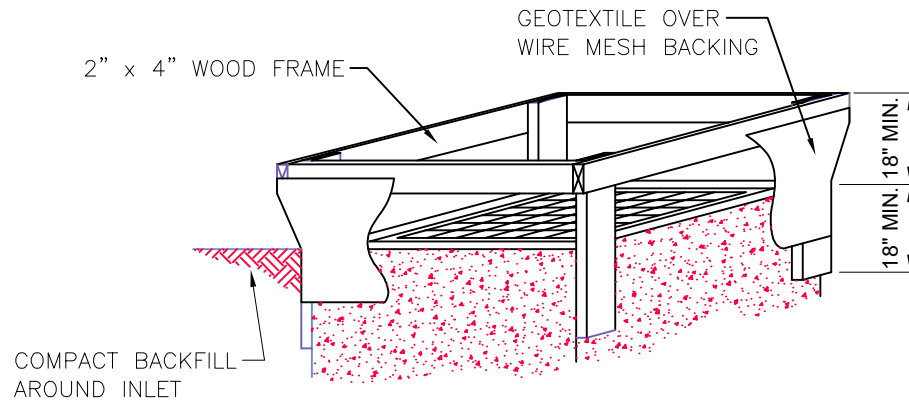

INLET PROTECTION IN SWALES, DITCH LINES OR YARD INLETS

- A. INLET PROTECTION SHALL BE CONSTRUCTED EITHER BEFORE UPSLOPE LAND DISTURBANCE BEGINS OR BEFORE THE STORM DRAIN BECOMES OPERATIONAL.
- B. THE EARTH AROUND THE INLET SHALL BE EXCAVATED COMPLETELY TO A DEPTH AT LEAST 18 INCHES.
- C. THE WOODEN FRAME SHALL BE CONSTRUCTED OF 2 INCH BY 4 INCH CONSTRUCTION GRADE LUMBER. THE 2 FOOT BY 4 FOOT POST SHALL BE DRIVEN 1 FOOT INTO THE GROUND AT FOUR CORNERS OF THE INLET AND THE TOP PORTION OF 2 INCH BY 4 INCH FRAME ASSEMBLED USING THE OVERLAP JOINT SHOWN. THE TOP OF THE FRAME SHALL BE AT LEAST 6 INCHES BELOW ADJACENT ROAD, IF PONDED WATER WOULD POSE A SAFETY HAZARD TO TRAFFIC.
- D. WIRE MESH SHALL BE OF SUFFICIENT STRENGTH TO SUPPORT FABRIC WITH WATER FULLY IMPOUNDED AGAINST IT. IT SHALL BE STRETCHED TIGHTLY AROUND THE FRAME AND FASTENED SECURELY TO THE FRAME.
- E. GEOTEXTILE SHALL HAVE AN EQUIVALENT OPENING SIZE OF 20-40 SIEVE AND BE RESISTANT TO SUNLIGHT. IT SHALL BE STRETCHED TIGHTLY AROUND THE FRAME AND FASTENED SECURELY. IT SHALL EXTEND FROM THE TOP OF THE FRAME TO 18 INCHES BELOW THE INLET NOTCH ELEVATION. THE GEOTEXTILE SHALL OVERLAY ACROSS ONE SIDE OF THE INLET SO THE ENDS OF THE CLOTH ARE NOT FASTENED TO THE SAME POST.
- F. BACKFILL SHALL BE PLACED AROUND THE INLET IN COMPACTED 6 INCH LAYERS UNTIL THE EARTH IS EVEN WITH NOTCH ELEVATION ON ENDS AND TOP ELEVATION ON SIDES.
- G. A COMPACTED EARTH DIKE OR A CHECK DAM SHALL BE CONSTRUCTED IN THE DITCH LINE BELOW THE INLET IF THE INLET IS NOT IN DEPRESSION AND IF RUNOFF NY PASSING THE INLET WILL NOT FLOW TO A SETTING POND. THE TOP OF EARTH DIKES SHALL BE AT LEAST 6 INCHES HIGHER THAN THE TOP OF THE FRAME

GRAVEL CURB INLET SEDIMENT FILTER NOTES

- A. HARDWARE CLOTH OR COMPARABLE WIRE MESH WITH ½ INCH OPENINGS SHALL BE PLACED OVER THE CURB INLET OPENING SO THAT AT LEAST 12 INCHES OF WIRE EXTENDS ACROSS THE INLET COVER AND AT LEAST 12 INCHES OF WIRE EXTENDS ACROSS THE CONCRETE GUTTER FROM THE INLET OPENING, AS ILLUSTRATED.
- B. STONE SHALL BE PILED AGAINST THE WIRE SO AS TO ANCHOR IT AGAINST THE GUTTER AND INLET COVER AND TO COVER THE INLET OPENING COMPLETELY. ODOT NO. 1 COARSE AGGREGATE SHALL BE USED.
- C. IF THE STONE FILTER BECOMES CLOGGED WITH SEDIMENT SO THAT IT NO LONGER PERFORMS ITS FUNCTION, THE STONE MUST BE PULLED AWAY FROM THE CATCH BASIN, CLEANED AND REPLACED.

CITY OF PIQUA

ACCESS
Engineering Solutions

TEMPORARY EROSION CONTROL SAMPLES

REVISIONS:

DATE
APPROVED:
DEC. 2016

PAGE No.
600-12

2-08-17 BG

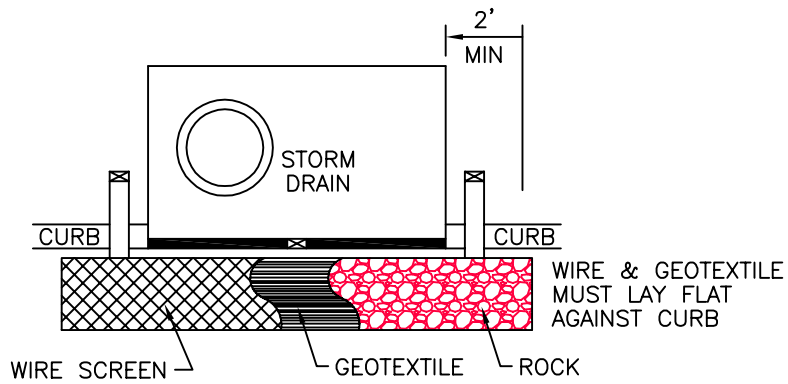

PLAN VIEW

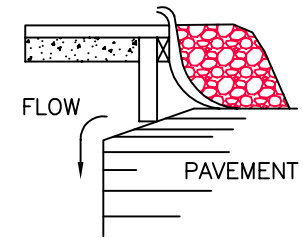

CROSS SECTION

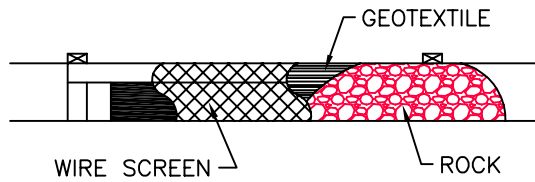

ELEVATION

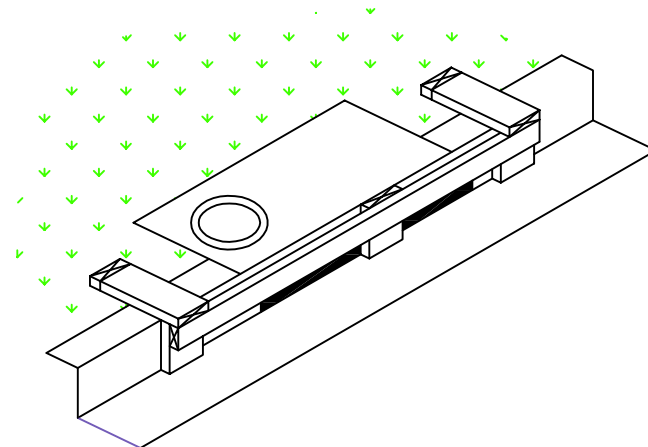

ISOMETRIC

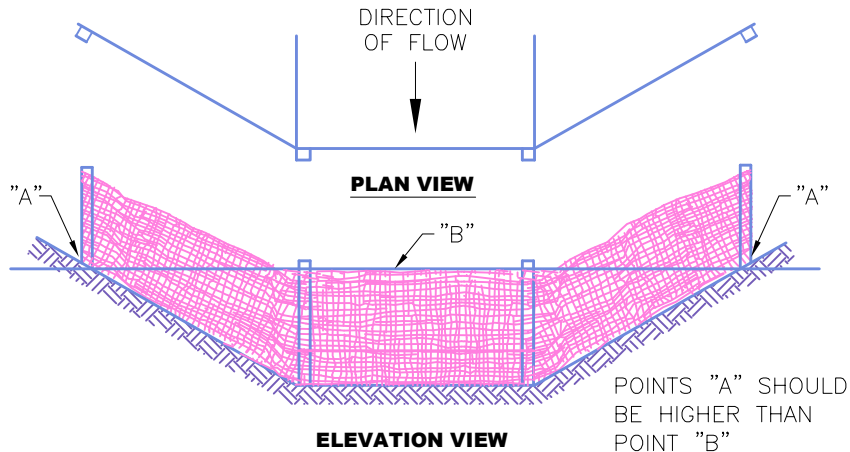

PLACEMENT AND CONSTRUCTION OF DITCH CHECK FILTER FABRIC FENCE

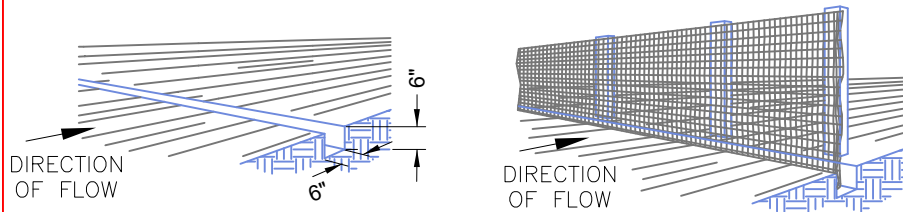

EXCAVATE A 6"X6" TRENCH ALONG THE PROPOSED FENCE LINE.

STEP 1

PLACE FABRIC AND SUPPORT STAKES AND EXTEND FABRIC INTO THE TRENCH.

STEP 2

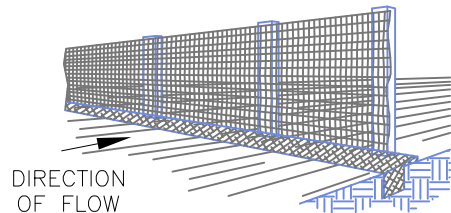

BACKFILL AND COMPACT THE EXCAVATED SOIL.

STEP 3

PLACEMENT AND CONSTRUCTION OF PERIMETER FILTER FABRIC FENCE

- A. SILT FENCE SHALL BE CONSTRUCTED BEFORE UPSLOPE LAND DISTURBANCE BEGINS.
- B. ALL SILT FENCE SHALL BE PLACED AS CLOSE TO THE CONTOUR AS POSSIBLE TO THAT WATER WILL NOT CONCENTRATE AT LOW POINTS IN THE FENCE AND SO THAT SMALL SWALES OR DEPRESSIONS WHICH MAY CARRY SMALL CONCENTRATED FLOWS TO THE SILT FENCE ARE DISSIPATED ALONG ITS LENGTH.
- C. TO PREVENT WATER PONDED BY THE SILT FENCE FROM FLOWING AROUND THE ENDS, EACH END SHALL BE CONSTRUCTED UP SLOPE SO THAT THE ENDS ARE AT A HIGHER ELEVATION.
- D. WHERE POSSIBLE, SILT FENCE SHALL BE PLACED ON THE FLATTEST AREA AVAILABLE.
- E. WHERE POSSIBLE, VEGETATION SHALL BE PRESERVED FOR 5 FEET (OR AS MUCH AS POSSIBLE) UPSLOPE FROM THE SILT FENCE, IF VEGETATION IS REMOVED, IT SHALL BE REESTABLISHED WITHIN 7 DAYS FORM THE INSTALLATION OF THE SILT FENCE.
- F. THE HEIGHT OF THE SILT FENCE SHALL BE A MINIMUM OF 16 INCHES ABOVE THE ORIGINAL GROUND SURFACE.
- G. THE SILT FENCE SHALL BE PLACED IN A TRENCH CUT A MINIMUM OF 6 INCHES DEEP. THE TRENCH SHALL BE CUT WITH A TRENCHER, CABLE LAYING MACHINE, OR OTHER SUITABLE DEVICE WHICH WILL ENSURE AND ADEQUATELY UNIFORM TRENCH DEPTH.
- H. THE SILT FENCE SHALL BE PLACED WITH THE STAKES ON THE DOWNSLOPE SIDE OF THE GEOTEXTILE AND SO THAT 8 INCHES OF CLOTH IS BELOW THE GROUND SURFACE. EXCESS MATERIAL SHALL LAY ON THE BOTTOM OF THE 6 INCH DEEP TRENCH. THE TRENCH SHALL BE BACKFILLED AND COMPACTED.
- I. SEAMS BETWEEN SECTIONS OF SILT FENCE SHALL BE OVERLAPPED WITH THE END STAKES OF EACH SECTION WRAPPED TOGETHER BEFORE DRIVING INTO THE GROUND.
- J. MAINTENANCE- SILT FENCE SHALL ALLOW RUNOFF TO PASS ONLY AS DIFFUSE FLOW THROUGH THE GEOTEXTILE. ALL THE GAPS AND TEARS IN THE FENCE MUST BE ELIMINATED AND REPAIRED IF RUNOFF OVERTOPS THE SILT FENCE, FLOWS UNDER OR AROUND THE ENDS, OR IN ANY OTHER WAY BECOME AS CONCENTRATED FLOW, ONE OF THE FOLLOWING SHALL BE PREFORMED, AS APPROPRIATE: 1) THE LAYOUT OF THE SILT FENCE SHALL BE CHANGED, 2) ACCUMULATED SEDIMENT SHALL BE REMOVED, OR 3) OTHER PRACTICES SHALL BE INSTALLED.

CRITERIA FOR SILT FENCE MATERIAL

- A. FENCE POSTS- THE LENGTH SHALL BE A MINIMUM OF 32 INCHES LONG, WOOD POSTS WILL BE 2 FEET-BY-2 FEET HARDWOOD OF SOUND QUALITY. THE MAXIMUM SPACING BETWEEN POSTS SHALL BE 10 FEET. SILT FENCE FABRIC SHALL BE ODOT TYPE C GEOTEXTILE FABRIC OR AS DESCRIBED BY THE CHART BELOW:

FABRIC PROPERTIES	
MINIMUM TENSILE STRENGTH	120 LBS
MAXIMUM ELONGATION AT 60 LBS	50%
MINIMUM PUNCTURE STRENGTH	50 LBS
MINIMUM TEAR STRENGTH	40 LBS
APPARENT OPENING SIZE	≤ 0.84 MM
MINIMUM PERMITTIVITY	1 X 10 ² SEC. ⁻¹
ULTRAVIOLET EXPOSURE STRENGTH RETENTION	70%

CONSTRUCTION OF A FILTER BARRIER (SILT FENCE)

CITY OF PIQUA



TEMPORARY EROSION CONTROL SAMPLES

REVISIONS:

DATE APPROVED:
DEC. 2016

PAGE No.
600-13

12-20-16 BG

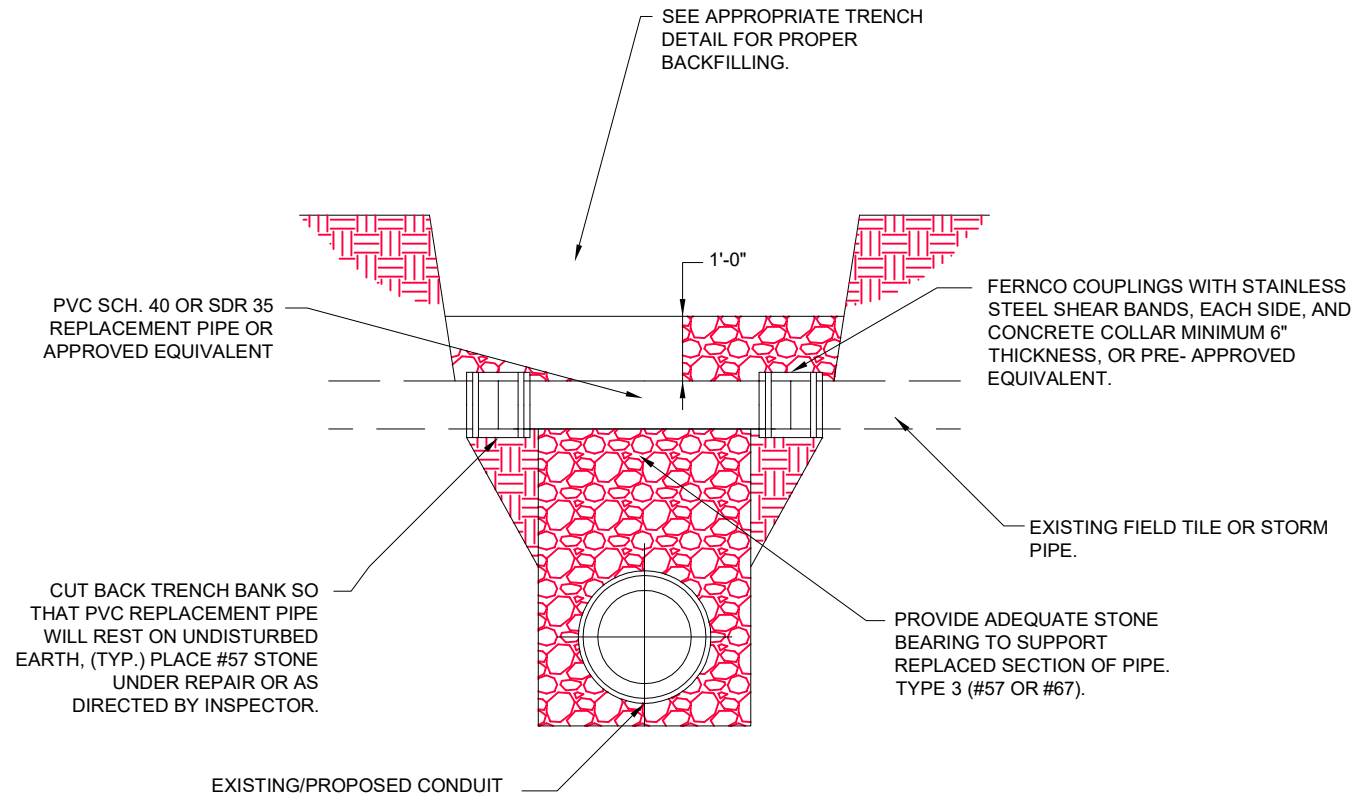

REPAIR OF EXISTING FIELD TILE OR STORM PIPE DETAIL

NOTE:
CONCRETE REPAIRS OR PATCHES ARE UNACCEPTABLE.

CITY OF PIQUA



**REPAIR OF EXISTING FIELD TILE
OR STORM PIPE DETAIL**

REVISIONS:

12-20-16 BG

DATE
APPROVED:
DEC. 2016

PAGE No.
600-14

800 – Water Distribution

HYDRANT PUMP NOZZLE
 4" I.D.
 5" O.D.
 4 THREADS PER INCH

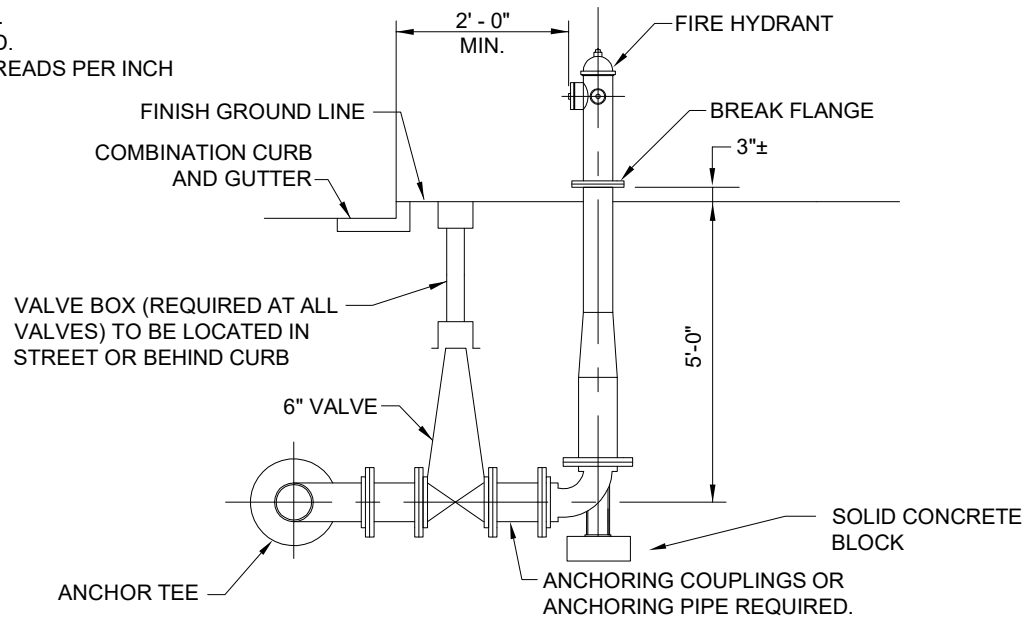

SECTION VIEW

NOTES

- A. FIRE HYDRANTS-MUELLER CENTURION, OR APPROVED EQUAL ,NO. A-423; MECHANICAL JOINT; TWO 2-1/2 INCH HOSE NOZZLE WITH NATIONAL STANDARD THREAD CONNECTIONS; PUMPER NOZZLE TO BE 5" STORTZ MANUFACTURED BY HARRINGTON OR APPROVED EQUAL.
- B. GATE VALVES SHALL BE AWWA C-515, RESILIENT WEDGE, NON-RISING STEM, MECHANICAL JOINT, 150 PSI WORKING PRESSURE, CCW TO OPEN WITH ARROW INDICATING OPEN DIRECTION, MUELLER OR EQUIVALENT.
- C. VALVE BOXES SHALL BE 3-PIECE, ADJUSTABLE 36 INCH TO 48 INCH. 5-1/4 INCH ADJUSTABLE SHAFT, 6 INCH DIAMETER NOMINAL, ADJUSTABLE SCREW TYPE, COVER MARKED "WATER", DOMESTICE MADE ONLY.
- D. ALL FITTINGS TO BE MEGALUG RESTRAINED AND THRUST BLOCKED.
- E. ALL FITTINGS TO BE AWWA C-153 DUCTILE IRON, COMPACT.
- F. ALL VALVES AND HYDRANTS SHALL OPEN LEFT BY TURNING IN A COUNTER CLOCKWISE DIRECTION.
- G. CONTRACTOR TO FACE HYDRANT AS REQUIRED BY THE CITY.
- H. WATER MAIN SHALL BE DUCTILE IRON PIPE CLASS 52 CEMENT LINED, AWWA C-151, WITH MECHANICAL JOINTS.
- I. THE LAYING OF PIPE ON EXISTING DIRT WITH THE BELLS CUT OUT SHALL NOT BE PERMITTED.
- J. THE OPEN ENDS OF ALL PIPES AND SPECIAL CASTINGS SHALL BE PLUGGED OR OTHERWISE CLOSED WITH A WATERTIGHT PLUG TO THE APPROVAL OF THE CITY BEFORE LEAVING THE WORK FOR THE NIGHT.
- K. THE FIRE DEPARTMENT SHALL COMPLETE A FUNCTION/FLOW TEST PRIOR TO BEING PLACED INTO SERVICE.
- L. ALL FIRE HYDRANTS MUST BE THRUST BLOCKED.

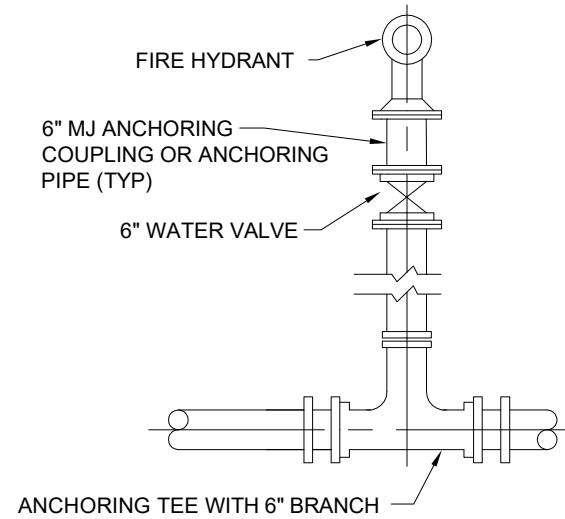

BASIC TEE DETAIL PLAN

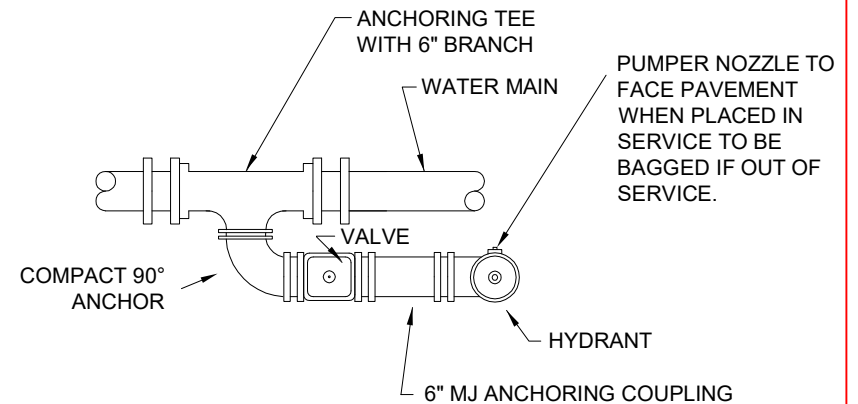

**SPECIAL MECHANICAL JOINT
 HYDRANT TEE DETAIL PLAN**

CITY OF PIQUA

FIRE HYDRANT



REVISIONS:

DATE
 APPROVED:
 DEC. 2016

PAGE No.
800-1

12-27-16 BG

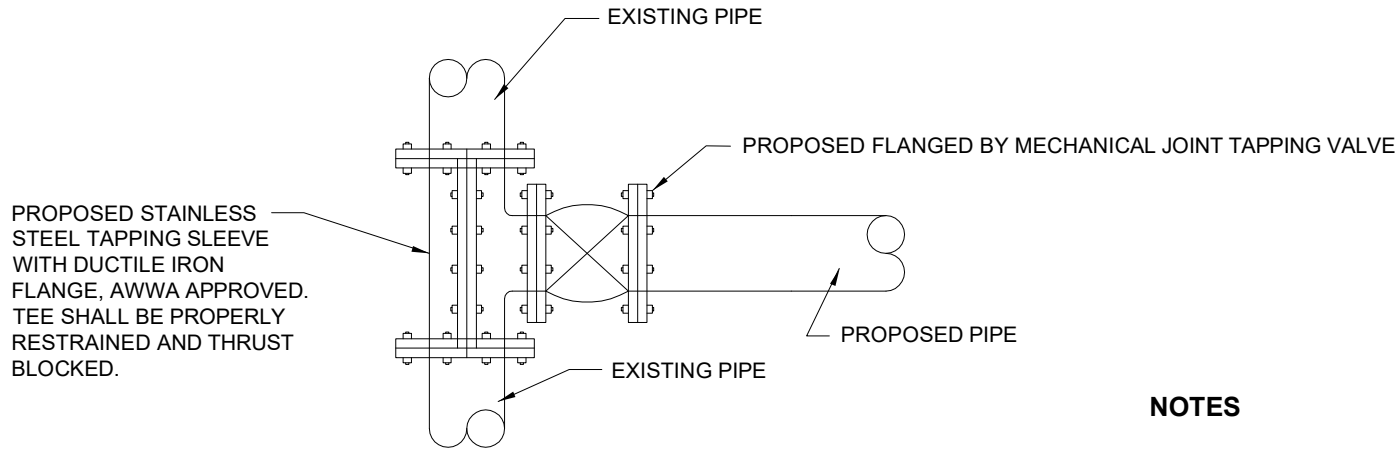

TAPPING SLEEVE AND VALVE DETAIL

NOTES

- A. ALL JOINTS TO BE RESTRAINED.
- B. BELL JOINT RESTRAINTS - USE FIELD LOCK BY U.S. PIPE OR APPROVED EQUIVALENT.
- C. MECHANICAL JOINT RESTRAINTS - EBAA IRON MEGALUG RETAINER GLAND OR EQUIVALENT.
- D. CONTRACTOR TO USE RESTRAINED JOINTS AND THRUST BLOCKING.

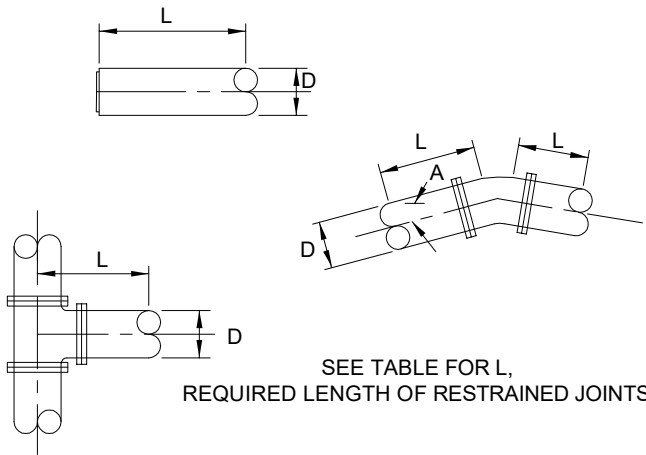

		REQUIRED LENGTH OF RESTRAINED JOINTS IN FEET							
		D-DIAMETER OF PIPE							
A ~ DEGREE OF DEFLECTION		4"	6"	8"	10"	12"	16"	20"	24"
		11 1/4"	20	20	20	20	20	20	20
	22 1/2"	20	20	20	20	20	20	20	20
	45'	20	20	20	20	20	20	20	20
	90'	20	25	33	40	47	60	72	85
	TEE	20	25	33	40	47	60	72	85
	END	20	25	33	40	47	60	72	85

DESIGN PARAMETERS

LAYING CONDITIONS - TYPE 5
 SOIL DESIGNATION - SILT
 DEPTH OF COVER - 4'-6"
 DESIGN PRESSURE - 80 PSI
 SAFETY FACTOR - 1.50
 BARE PIPE
 THIS CHART AND PARAMETERS WILL BE UTILIZED UNLESS APPROVED BY THE UTILITY DIRECTOR..

REQUIRED LENGTH OF RESTRAINED FEILD LOCK OR MEGALUG JOINTS FOR WATER MAINS

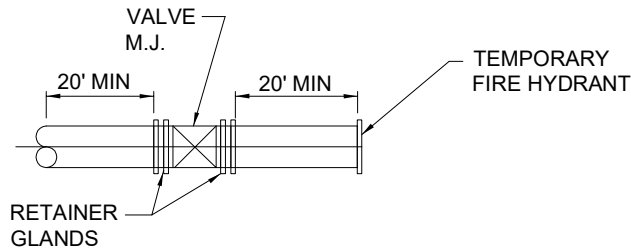

DETAIL - END OF WATER LINE

BENDS								
SIZE OF PIPE	DEGREE OF BEND							
	11 1/4°		22 1/2°		45°		90°	
	L	D	L	D	L	D	L	D
3", 4", 6"	8"	6"	10"	6"	20"	6"	36"	6"
8"	9"	8"	14"	8"	24"	9"	50"	8"
12"	14"	12"	22"	12"	30"	16"	60"	15"
16"	18"	16"	24"	18"	33"	36"	70"	22"

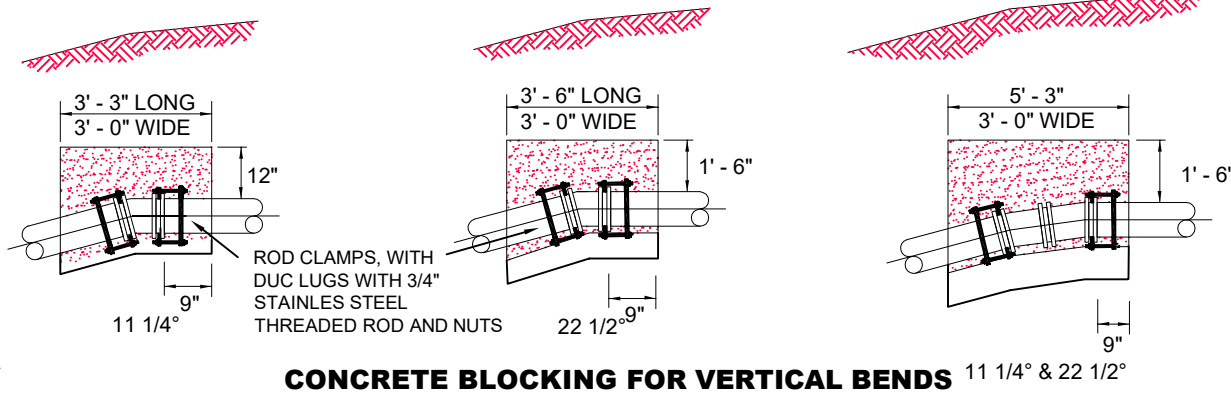

CONCRETE BLOCKING FOR VERTICAL BENDS

TEES								
RUN	BRANCH							
	3", 4", 6"		8"		12"		16"	
	L	D	L	D	L	D	L	D
3", 4", 6"	16"	6"						
8"	14"	8"	18"	12"				
12"	9"	12"	18"	12"	24"	18"		
16"	8"	16"	14"	16"	28"	16"	30"	26"

NOTES

- A. CARE SHALL BE TAKEN TO KEEP CONCRETE AWAY FROM MECHANICAL JOINTS BY PLACING VISQUEEN OR OTHER PREAPPROVED MATERIAL OVER PIPE BEFORE PLACING OF CONCRETE. BOLTS SHALL NOT BE ENCASED IN CONCRETE.
- B. CONCRETE FOR BLOCKING VALVES AND FITTINGS SHALL CONFORM TO SECTION ODOT 499 QCI CONCRETE, ALLOW 72 HOURS FOR SETTING OF CONCRETE PRIOR TO FILLING WATER MAIN.
- C. CONTRACTOR SHALL USE THE THRUST BLOCKS AS SHOWN.
- D. ALL VERICAL THRUST BLOCK IS TO BE ACCOMPANIED WITH ROD CLAMPS AND DUC LUGS WITH 3/4" STAINLESS STEEL THREADED RODS.

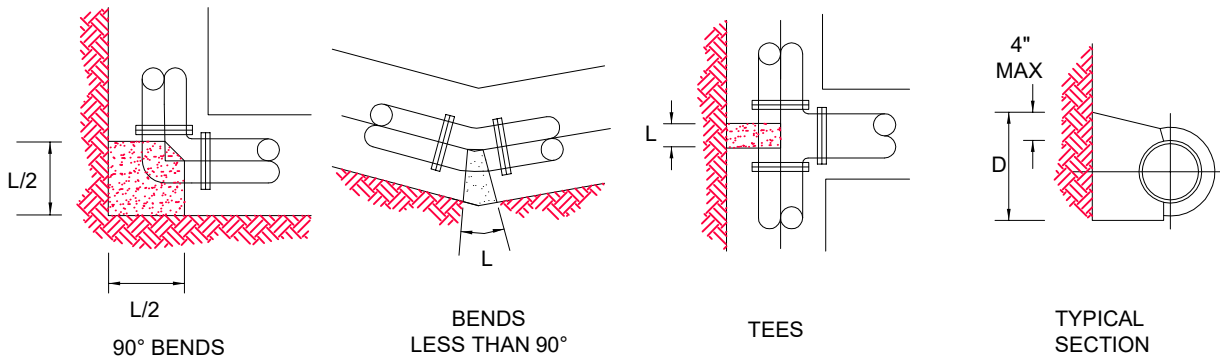

CONCRETE BLOCKING FOR HORIZONTAL BENDS

CITY OF PIQUA



CONCRETE BLOCKING FOR WATER MAINS

REVISIONS:

DATE APPROVED:
DEC. 2016

PAGE No.
800-3

02-08-17 BG

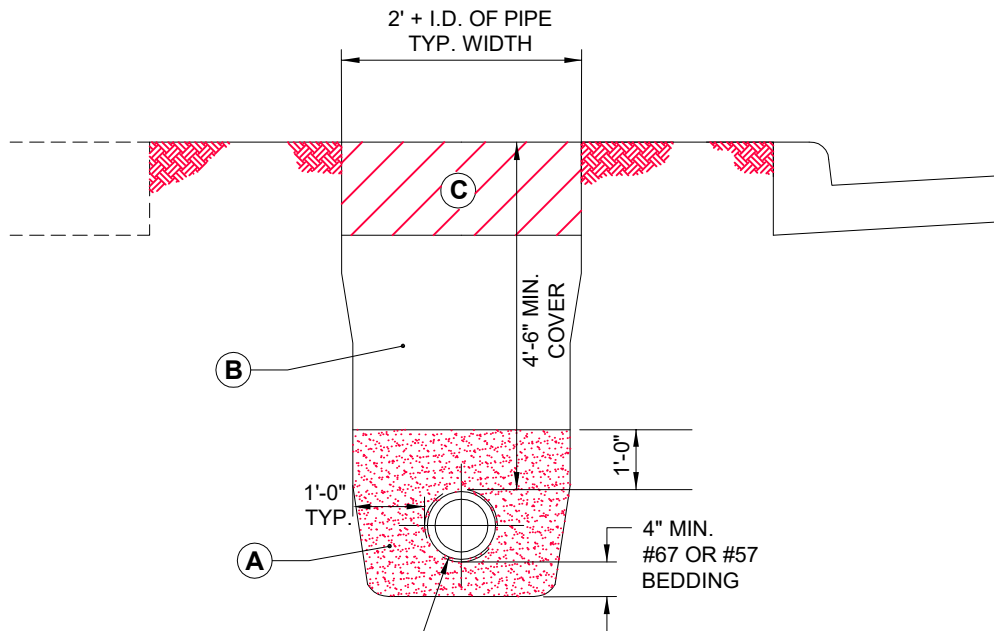

PROPOSED WATER MAIN **WATER MAIN TRENCH DETAIL**

TRENCH DETAIL NOTES

WATER MAIN CROSSING SEPARATION

WHENEVER A SANITARY SEWER AND WATER LINE MUST CROSS, THE SEWER SHALL BE LAID AT SUCH AN ELEVATION THAT THE CROWN OF THE SEWER IS AT LEAST 18 INCHES BELOW THE BOTTOM OF THE WATER LINE. IF IT IS ABSOLUTELY IMPOSSIBLE TO MAINTAIN THE 18-VERTICAL SEPARATION, THE SANITARY SEWER SHALL BE CONSTRUCTED WITH WATER LINE TYPE MATERIALS WHICH WILL BE CONSTRUCTED WITH WATER LINE TYPE MATERIALS WHICH WILL WITHSTAND A 50 PSI PRESSURE TEST. THESE REQUIREMENTS WILL EXTEND FOR A DISTANCE OF 10 FEET, MEASURED PERPENDICULAR ON BOTH SIDES OF THE WATER LINE.

AT CROSSINGS, THE WATER MAIN SHALL HAVE A MINIMUM VERTICAL DISTANCE OF 18 INCHES FROM STORM AND SANITARY SEWERS. ALSO ONE FULL LENGTH OF WATER MAIN SHALL BE LOCATED SO THE JOINTS ARE AS FAR FROM THE STROM SANITARY SEWERS AS POSSIBLE.

A. GRANULAR BEDDING SHALL BE CRUSHED STONE OR GRAVEL, (#57 OR #67) OR OTHER APPROVED EQUIVALENT.

B. ALL TRENCHES OUTSIDE THE RIGHT-OF-WAY FROM PROPOSED OR EXISTING PAVEMENT, CURB, DRIVEWAYS, ALLEYS, STONE AREAS OR WALKS CAN BE COMPACTED WITH EXISTING NATIVE MATERIAL IN 12 INCH MAXIMUM LIFTS OR AS APPROVED BY THE CITY. NO MATERIAL SHALL BE USED FOR BACK FILLING THAT CONTAINS STONE, ROCKS, ETC., GREATER THAN 4 INCH DIAMETER.

ALL TRENCHES INSIDE THE RIGHT-OF-WAY FROM PROPOSED OR EXISTING PAVEMENT, CURB, DRIVEWAYS, ALLEYS, STONE AREAS OR WALKS SHALL BE COMPACTED WITH GRANULAR BACKFILL MATERIAL #304, #411 IN 6 INCH MAXIMUM LIFTS.

A DENSITY TEST ON GRANULAR BACKFILL OF 98% OF ASTMA D698 STANDARD PROCTOR CURVE MAY BE REQUIRED TO BE PERFORMED BY A COMMERCIAL TESTING LAB SATISFACTORY TO THE CITY.

C. OFF-PAVEMENT AREAS SHALL BE PROVIDED WITH A MINIMUM OF 6 INCHES OF TOPSOIL OVER THE COMPACTED MATERIAL AND THEN SEEDED AND MULCHED PER ODOT ITEM 659.

ALL PAVED AREAS WITHIN THE STREET RIGHT-OF-WAY SHALL FOLLOW THE REQUIREMENTS OF PAGES 300-15 OF THE STANDARD DRAWINGS.

D. THE OPEN ENDS OF ALL PIPES SHALL BE PLUGGED WITH A WATER TIGHT PLUG TO THE APPROVAL BY THE CITY BEFORE LEAVING THE WORK FOR THE NIGHT.

CITY OF PIQUA



WATER MAIN TRENCH DETAIL

REVISIONS:

12-27-16 BG

DATE APPROVED:
DEC. 2016

PAGE No.
800-4

MATERIAL SPECIFICATIONS

- A. WATER MAIN SHALL BE AWWA C-151 DUCTILE IRON PIPE CLASS 52 FOR 4 INCH TO 16 INCH AND CLASS 54 FOR 20 INCH AND GREATER, SLIP JOINT-ON JOINT AND RUBBER GASKETS.
- B. BELL JOINT RESTRAINTS- USE FIELD LOCK BY U.S. PIPE OR APPROVED EQUAL.
- C. MECHANICAL JOINT RESTRAINTS- EBAA IRON MEGALUG RETAINER GLAND OR EQUAL.
- D. FIRE HYDRANTS- MUELLER CERTURION No. A-423 MECHANICAL JOINT; TWO 2 ½ INCH HOSE NOZZLES WITH NATIONAL STANDARD THREAD CONNECTIONS; PUMPER CONNECTION TO BE A 5" STORTZ ; TO OPEN; NON DRAINING; BREAK FLANGES 3 INCHES ABOVE GRADE.COLORS OF HYDRANTS WILL BE RED WITH A WHITE CAP,AND A BLUE RING AROUND BONNETFLANGE, TO INDICATE THAT IT IS NON-DRAINING.
- E. GATE VALVES (THRU 10 INCHES)- AWWA C-515, RESILIENT WEDGE , NON-RISING STEM, MECHANICAL JOINT, 150 PSI WORKING PRESSURE, CCW TO OPEN, OPEN LEFT WITH ARROW INDICATING OPEN DIRECTION.
- F. VALVE BOXES- 3-PIECE CAST IRON 6 INCH DIAMETER NOMINAL, ADJUSTABLE SCREW TYPE, COVER MARKED "WATER" DOMESTIC MADE ONLY.
- G. SERVICE LINE- TYPE "K" COPPER TUBE WITH COMPRESSION OR FLARED TYPE FITTINGS. ALL FITTINGS TO BE LEAD FREE.
- H. CURB STOP- BRASS CONFORMING TO AWWA C-800, 300 PSI RATED (FORD, MUELLER, CUMBRIDGE OR MCDONALD)
- I. CURB BOXES-2 ½ INCH SCREW TYPE, BUFFALO STYLE CAST IRON LID WITH PENTAGON HEAD PLUG EM2-45-67, ONLY IN APPROVED SITUATIONS. METER PITS ONLY IN NEW CONSTRUCTION.
- J. ALL SERVICE CONNECTIONS REQUIRE A METER AND OUTSIDE METER PIT (FOR NEW CONSTRUCTION)

K, VALVE SIZING

- 6 INCH TO AND INCLUDING 10 INCH TO BE A GATE VALVE OPENING LEFT
- 12 INCHES AND LARGER-TO BE A BUTTERFLY VALVE OPENING LEFT

HYDROSTATIC TEST

- A. AFTER THE PIPE HAS BEEN LAID AND BLACKFILLED, ALL NEWLY LAID PIPE OR VALVED SECTION, SHALL BE SUBJECTED TO HYDROSTATIC PRESSURE DN LEAKAGE TEST. ALL WATER MAINS MUST BE HYDROSTATICALLY TESTED (AWWA C-600). THE TEST MUST BE PERFORMED BY THE CONTRACTOR IN THE PRESENCES OF A REPRESENTATIVE OF THE CITY OF PIQUA. THE LEAKAGE TEST PRESSURE SHALL BE NOT LESS THAN 200 PSI FOR MAINS ADN 150 PSI FOR COPPER SERVICES. THE DURATION OF THE LEAKAGE TEST SHALL NOT BE LESS THAT 2 HOURS. HYDROSTATIC PRESSURE SHALL BE APPLIED BY MEANS OF A PUMP TAKING WATER FROM AN AUXILIARY SUPPLY. ALL PIPING MUST BE PROPERLY FILLED AND FLUSHED TO DISPEL ALL AIR AND DEBRIS BEFORE THE TEST IS MADE USING POTABLE WATER.
- B. LEAKAGE IS DEFINED AS THE QUANTITY OF WATER TO BE SUPPLIED INT THE NEWLY LAID PIPE, OR ANY VALVE SECTION THEREOF, NECESSARY TO MAINTAIN THE SPECIFIED LEAKAGE TEST PRESSURE AFTER THE PIPE HAS BEEN FILLED WITH WATER AND THE AIR EXPELLED.
- C. DURING THE HYDROSTATIC TEST, A THOROUGH EXAMINATION OF ALL PIPING, FITTINGS, VALVES, AND HYDRANTS SHALL BE PERFORMED. LEAKING JOINTS SHALL BE TIGHTENED AND THE TEST SHALL BE REPEATED UNTIL SATISFACTORY RESULTS ARE OBTAINED. CRACKED OR OTHERWISE DEFECTIVE MATERIAL SHALL BE REMOVED AND REPLACED AND THE TEST SHALL BE REPEATED UNTIL SATISFACTORY RESULTS ARE OBTAINED.

AVG. TEST PRESSURE (PSI) BAR	ALLOWABLE LEAKAGE PER 1000 FT (305M) OF PIPELINE (GPH+)									
	NOMINAL PIPE DIAMETER - INCHES									
	6	8	10	12	14	16	18	20	24	30
250 (17)	0.71	0.95	1.19	1.42	1.66	1.90	2.14	2.37	2.85	3.56
225 (16)	0.68	0.90	1.13	1.35	1.58	1.80	2.03	2.25	2.70	3.38
200 (14)	0.64	0.85	1.06	1.28	1.48	1.70	1.91	2.12	2.55	3.19
175 (12)	0.59	0.80	0.99	1.19	1.39	1.59	1.79	1.98	2.38	2.98
150 (10)	0.55	0.74	0.92	1.10	1.29	1.47	1.66	1.84	2.21	2.76
120 (9)	0.50	0.67	0.84	1.01	1.18	1.34	1.51	1.68	2.01	2.52

DISINFECTION

- A. AFTER SATISFACTORY HYDROSTATIC TESTING, THE COMPLETED WATER WORK SHALL BE DISINFECTED IN ACCORDANCE WITH AWWA C-651 BY THE CONTRACTOR, WITH THE CITY OF PIQUA OVERSEEING, BY MEANS OF LIQUID SODIUM HYDROCHLORIDE INJECTION, AFTER INJECTION TEST SHOULD INDICATE 50 PARTS PER MILLION (PPM) OR HIGHER OF CHLORINE. THE RESIDUAL AFTER 24 HOURS MUST BE 25 PPM OR HIGHER.
- B. CHLORINATION TAPS SHALL BE WITH 18 INCHES FROM THE END OF THE PIPE OR VALVE
- C. MAINTAIN PIPES FREE OF DIRT AND FOREIGN MATTER DURING CONSTRUCTION BY DEWATERING TRENCH AND SEALING OPEN PIPE BARRELS. THIS IS ALSO A REQUIREMENT IF REPAIRS OCCUR.
- D. DECHLORINATE WATER WITH APPROVED AWWA METHOD APPROVED BY THE CITY OF PIQUA.
- E. WATER SAMPLES- PERFORM BACTERIOLOGICAL TEST PER AWWA C-651. THIS TEST WILL BE PERFORMED BY PER CITY SCHEDULED PERMITS. AT LEAST ONE SET OF SAMPLES SHALL BE COLLECTED FROM EVERY 1,200 FEET OF NEW WATER MAIN, PLUS ONE SET FROM THE END OF THE LINE AND AT LEAST ONE SET FROM EACH BRANCH. TWO CONSECUTIVELY NEGATIVE RESULTS WILL CONSTITUTE A PASSABLE TEST. THE CONTRACTOR SHALL FURNISH ALL REQUIRED TESTING APPENDAGES OR EXCAVATION NEEDED BY THE CITY.
- F. ADDITIONAL TESTING SHALL BE AT THE CONTRACTORS EXPENSE AND CANNOT CREATE OVERTIME COST UNLESS CONTRACTOR IS WILLING TO PAY FOR IT.
- G. ALL CONNECTIONS FROM PROPOSED TO EXISTING MAINS ARE TO BE HAND SWABBED WITH LIQUID SODIUM HYDROCHLORIDE.

CITY OF PIQUA



WATER MAIN MATERIAL AND TESTING

REVISIONS:

DATE APPROVED:
DEC. 2016

PAGE No.
800-5

02-08-17 BG

NOTES

- A. NO WORK SHALL BE APPROVED OR ACCEPTED BY THE CITY UNLESS 2 WORKING DAYS NOTICE OF COMMENCING WORK IS GIVEN TO THE CITY, ALL WORK MUST BE PRE-APPROVED.
- B. ALL TEMPORARY PAVEMENT AND SIDEWALK SHALL BE MAINTAINED BY THE CONTRACTOR OR THE DEVELOPER AT HIS OWN EXPENSE IS A SUITABLE AND SAFE CONDITION FOR TRAFFIC UNTIL PERMANENT REPLACEMENT IS MADE OR THE PROJECT IS FINALLY ACCEPTED BY THE CITY, UNLESS OTHERWISE APPROVED.
- C. THE MINIMUM LENGTH OF PIPE NIPPLES SHALL BE 18 INCHES UNLESS OTHERWISE APPROVED BY THE CITY.
- D. ALL CUSTOMERS SHALL MEET BACKFLOW PREVENTION REQUIREMENTS AS PER CITY OF PIQUA STANDARDS.
- E. ALL WATERLINE CONSTRUCTION INCLUDING EXTENSIONS ON PRIVATE PROPERTY SHALL FOLLOW MIAMI COUNTY PLUMBING REGULATIONS, ODOT 638 AND/OR AWWA STANDARDS WHICHEVER IS MORE RESTRICTIVE AS DETERMINED BY THE CITY AND THE COUNTY INSPECTOR.
- F. OPERATION OF CITY FIRE HYDRANTS, VALVES, METERS, SERVICES, STOPS AND ALL OTHER MECHANICAL INFRASTRUCTURE ITEMS IS STRICTLY PROHIBITED ACCORDING TO ORDINANCE 53.41
- G. ALL WATER MAINS SHALL HAVE A MINIMUM DEPTH OF 4 1/2' AND A MAXIMUM DEPTH OF 6 FEET FROM TOP OF PIPE TO THE SURFACE, UNLESS REQUIRED BY DESIGN.
- H. SERVICE LINE AND METER SETTING INSTALLATIONS AND ALL ASSOCIATED COSTS, INCLUDING ALL MATERIALS, PERMITS, LABOR, EXCAVATION, EQUIPMENT, AND ALL METERS TWO INCHES AND LARGER, AND DETECTOR CHECK METERS ARE THE RESPONSIBILITY OF THE CUSTOMER. ACCORDING TO CITY ORDINANCE 53.44-C

PIPE

- A. ALL PIPE FITTINGS SHALL BE DUCTILE IRON.
- B. WATER MAIN MINIMUM SIZE UNLESS OTHERWISE APPROVED
 - RESIDENTIAL 8"
 - COMMERCIAL 10"
 - INDUSTRIAL 12"
 6" MAY BE CONSIDERED FOR LOOPING PURPOSES IN RESIDENTIAL AREAS.
- C. DEADENDS ARE NOT PERMITTED AND MUST BE LOOPED UNLESS THEY ARE DEEMED UNPRACTICAL BY THE CITY ENGINEERING DEPARTMENT AFTER A REVIEW OF WATER MAIN DESIGN. WHEN APPROVED, THEY SHALL BE TERMINATED WITH A FIRE HYDRANT AT THE END

EXCAVATION AND PIPE LAYING

- A. THE OPEN ENDS OF THE ALL PIPES SHALL BE CLOSED WITH A WATERTIGHT PLUG WITH THE APPROVAL OF THE CITY BEFORE LEAVING THE WORK FOR THE NIGHT AND AT OTHER TIMES OF INTERRUPTION OF THE WORK.

STORAGE AND HANDLING OF MATERIALS

- A. PIPE FITTINGS, VALVES FIRE HYDRANTS AND OTHER MATERIALS MUST BE PROPERLY STORED ON THE JOB SITE. PROPER TOOLS FOR THE SAFE AND CONVENIENT HANDLING AND PLACING OF PIPE AND FITTINGS SHALL BE USED. CARE SHALL BE TAKEN TO PREVENT DAMAGE COATINGS OF THE PIPE AND FITTINGS, AND ANY DAMAGE SHALL BE REMEDIED AS DIRECTED. NO DAMAGED OR DEFECTIVE PIPE OR FITTINGS SHALL BE USED.
- B. PIPES AND FITTINGS SHALL BE THOROUGHLY CLEANED BEFORE THEY ARE USED, AND SHALL BE KEPT CLEAN UNTIL WORK IS COMPLETED BY USING WATER TIGHT PLUGS ON OPEN ENDS OF PIPES IN THE GROUND.

FITTINGS, VALVES AND HYDRANTS

- A. FITTINGS OR SPECIALS IN SIZES 12 INCH THROUGH 48 INCH SHALL CONFORM TO ALL REQUIREMENTS OF AWWA C-153, FITTINGS AND SPECIALS 12 INCHES AND SMALLER SHALL BE CLASS 250. LARGER FITTINGS AND SPECIALS SHALL BE CLASS 150. FITTINGS AND SPECIALS SHALL HAVE MECHANICAL JOINTS AND SHALL DUCTILE IRON. CLUSTER VALVES WHENEVER POSSIBLE UNLESS APPROVED BY THE CITY.
- B. MAXIMUM SPACING UNLESS OTHERWISE APPROVED.

	HYDRANTS	VALVES
SINGLE AND TWO FAMILY RESIDENTIAL	300'	900'
INDUSTRIAL, COMMERCIAL & MULTI-FAMILY	300'	500'
- C. ALL TEES AND CROSSES SHALL BE VALVED IN EACH DIRECTION UNLESS OTHERWISE APPROVED.
- D. NO VALVE SHALL BE OPERATED BY PERSONNEL OTHER THAN A REPRESENTATIVE EMPLOYED BY THE CITY.
- E. ALL FITTINGS MUST BE DOMESTIC MADE ONLY.

UTILITY STAKING

- A. OFFSETS EVERY 25 FEET ON CURVES, OFFSETS EVERY 100 FEET ON STRAIGHT SECTIONS. FLOW LINE OF WATER MAIN (CUT) MARKED EVERY 100 FEET AND OFFSETS SHALL BE CLEARLY MARKED AND EVERY HYDRANT WITH TOP OF CURB ELEVATION.

NOTES

- A. METER PIT TO BE LOCATED AS DIRECTED BY THE CITY.
- B. METER SET FEE TO BE PAID PRIOR TO METER INSTALLATION.
- C. UNSATISFACTORY INSTALLATION WILL RESULT IN WATER NOT BEING TURNED ON.
- D. METER PIT LID MUST BE FLUSH WITH FINISHED GRADE. IF FRAME OF METER LID IS SHOWING, POSSIBILITY OF FREEZING OF METERS AND SERVICE LINES IS INCREASED. CITY'S RESPONSIBILITY STOPS AT THE CURB STOP OR METER PIT.
- E. SINGLE CHECK ANGLE VALVE ON OUTLET SIDE OF METER.

WATER PIT NOTES FOR 2" SERVICE

- 1. CORPORATION STOP-FORD METER BOX FB-600NL
- 2. TUBE NUT-MUELLER 3H-15430.
- 3. COPPER TUBE 2 INCH TYPE "K".
- 4. ASSEMBLY METER SETTTER VBB77-95251-003-NL W/ BYPASS FORD METER BOX COMPANY (AS PER CITY SPECS)
- 5. METER BOX COVER, 20 INCH MINIMUM LID OPENING, MC36 MONITOR COVER, WITH A 21- 15/16" X 40K TRUMBULL MANUFACTURING POLY LID
- 6. METER BOX, HANCOR PIPE OF EQUIVALENT, 36 INCH DIAMETER x 36 INCH HIGH x 2 INCH WALL.
- 7. IF METER IS REMOVED FROM PREMISES; THE OWNER MUST PAY FOR NEW METER AND SET UP FEE. METER SHALL BE A SENSUS OMNI C2 WITH 17" LAY LENGTH, THIS METER IS THE PROPERTY OWNERS RESPONSIBILITY, ALLOW SIX WEEKS FOR METER SET AND METER.
- 8. WATER SERVICE SHALL BE MINIMUM OF 18 INCHES ABOVE THE CROWN OF THE SANITARY SEWER MAIN WHERE THE WATER SERVICE CROSSES THE SEWER MAIN. WATER SERVICE MAY BE LAID ON BENCH IN THE SEWER LATERAL TRENCH IF CROWN IS AT LEAST 18 INCHES BELOW INVERT OF WATER SERVICE, AND THE MINIMUM DISTANCE BETWEEN THE WATER SERVICE AND THE SEWER LATERAL IS 5 FEET.
- 9. ALL EXISTING WATER MAIN AND SERVICE TO REMAIN ACTIVE UNTIL NEW MAIN HAS BEEN PLACED INTO SERVICE.
- 10. ALL CURB BOXES OR METERS PITS SHALL BE SET IN THE RIGHT OF WAY ON THE HOUSE SIDE BEHIND THE CURB, AS SHOWN IN PLANS.

NOTE: LID LOCKING BOLT MUST HAVE A STANDARD 27/32 INCH PENTAGON HEAD.

SUBSTITUTION OF MATERIALS LISTED MAY BE MADE ONLY IF APPROVED BY THE CITY OF PIQUA UNDERGROUND UTILITIES DEPARTMENT, 123 BRIDGE STREET PIQUA, OH 45356.

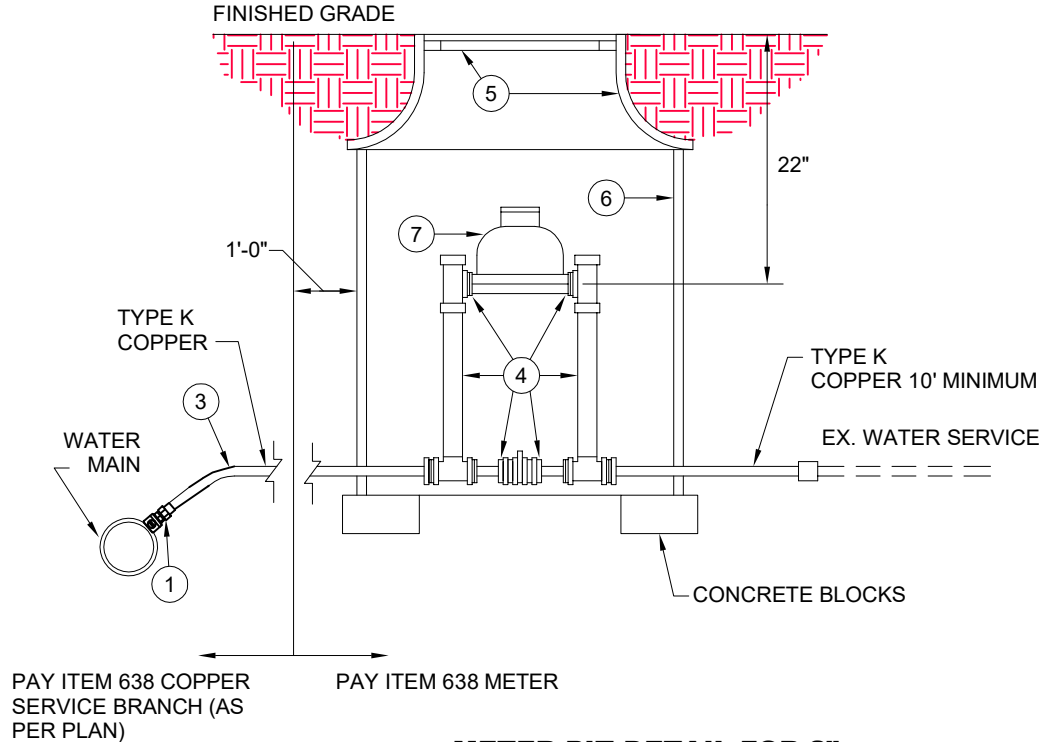

METER PIT DETAIL FOR 2"

COMPLETE METER INSTALLATION MUST COMPLY WITH THE CITY OF PIQUA'S SPECIFICATIONS



CITY OF PIQUA

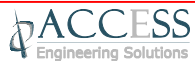

2" METER PIT INSTALLATION

REVISIONS:
02-08-17 BG
05-10-18 BG

DATE APPROVED:
DEC. 2016

PAGE No.
800-7

WATER PIT NOTES FOR 3/4" and 1" SERVICES

1. CORPORATION STOP-FORD METER BOX FB-600NL.
2. TUBE NUT-FORD METER BOX COMPANY.
3. COPPER TUBE 2 INCH TYPE "K".
4. YOKE ANGLE VALVE-FORD METER BOX COMPANY.
5. YOKE-FORD METER BOX COMPANY, 500 SERIES.
6. METER BOX- HANCORE DUAL WALL PIPE (BOX MUST BE 18" X 36" FOR 5/8" X 3/4" METER AND 24" X 36" FOR 1" OR DUAL METERS)
7. METER BOX COVER, FORD A32 11 1/2" LID HOLE SIZE FOR A TILE SIZE OF 18", EXT-1 EXTENSION RING FOR A 24" TILE. LID SHALL BE TRUMBULL MANUFACTURING, 167-0074 PENTAGON BOLT, 167-3009 WASHER, 1859 WORM GEAR, STYLE "P", MS. WIDE PLAIN WASHERS, 167-5764 12-1/4" OD METER LID POLYPROPYLENE, M5X 8X12 MACHINE SCREW.
NOTE. METER BOX COVER IS A INSIDE DIMENSION, THE LID SIZE IS 1" LARGER.
8. LOCKING NUT-FORM METER BOX COMPANY.
9. IF METER IS REMOVED FROM THE PREMISES THEN THE OWNER MUST PAY FOR A NEW METER AND A METER SET UP FEE.
10. WATER SERVICE SHALL BE A MINIMUM OF 18" ABOVE THE CROWN OF THE SANITARY SEWER MAIN WHERE THE WATER SERVICE CROSSES THE SEWER MAIN. WATER SERVICE MAY BE LAID ON BENCH IN THE SEWER LATERAL TRENCH IF CROW IS AT LEAST 18" BELOW THE INVERT OF THE WATER SERVICE AND THE SEWER LATERAL IS 5'-0".
11. ALL EXISTING WATER MAIN AND SERVICES TO REMAIN ACTIVE UNTIL NEW MAIN HAS BEEN PLACED INTO SERVICE.
12. CURB OR METERS SHALL BE SET IN THE CURB LAWN OR BEHIND BOX, AS SHOWN IN PLANS.
13. ANGLE CARTRIDGE STYLE DUAL CHECK VALVE ASSE 1024 METER YOKE INLET BY FLARE COPPER OUTLET- FORD METER BOX HHCA92 OR APPROVED EQUAL (CUSTOMER SIDE ONLY) SEE*

* OHIO PLUMBING CODE: SEC. 607.3.2. "BACKFLOW PREVENTION DEVICE OR CHECK VALVE" SPECIFIES THAT "WHERE A BACKFLOW PREVENTION DEVICE, CHECK VALVE, OR OTHER DEVICE IS INSTALLED ON A WATER SUPPLY SYSTEM UTILIZING STORAGE WATER HEATING EQUIPMENT SUCH THAT THERMAL EXPANSION CAUSES AN INCREASE IN PRESSURE, A DEVICE FOR CONTROLLING PRESSURE SHALL BE INSTALLED."

NOTES

- A. LID LOCKING BOLT MUST HAVE A STANDARD 27/32" PENTAGON HEAD.
- B. SUBSTITUTION OF MATERIALS LISTED MY BE MADE ONLY IF PRE-APPROVED BY THE CITY OF PIQUA UNDERGROUND UTILITIES DEPARTMENT.
- C. NO PLASTIC OR SOLDERED JOINTS IN METER PIT.
- D. ALL BRASS FITTINGS TO BE FOR, MUELLER, A.Y. MCDONALD, CAMBRIDGE OR APPROVED DOMESTIC FITTINGS. CONNECTION MUST BE LEAK FREE AND INSPECTED BY THE UNDERGROUND UTILITIES DEPARTMENT.
- E. FLARE OR COMPRESSION MAY BE USED.
- F. DO NOT CROSS COPPER TUBING IN METER PIT.
- G. THE LID TO WATER PIT MUST BE LEVEL WITH FINISH GRADE PRIOR IN INSTALLING WATER METER. METER PIT MUST BE NOT LESS THAN 3'0" FROM THE FLAIR OF A DRIVEWAY OR APPROACH

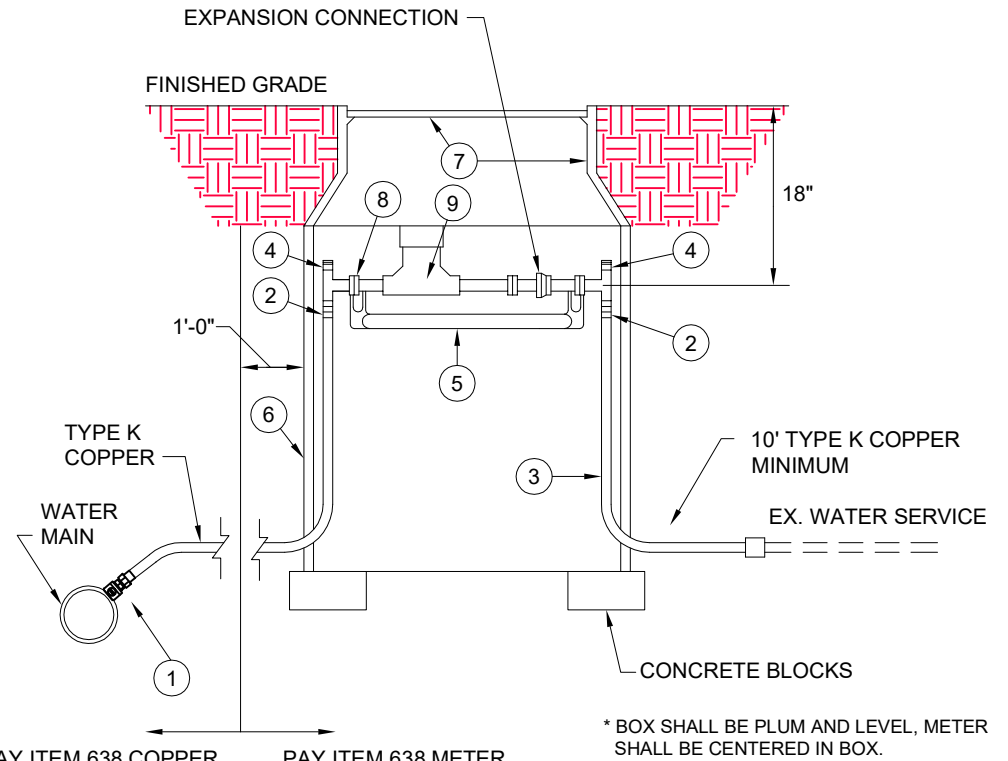

METER PIT DETAIL FOR 3/4" AND 1"



CITY OF PIQUA



3/4" AND 1" METER PIT INSTALLATION

REVISIONS:
02-08-17 BG
05-10-18 BG

DATE APPROVED:
DEC. 2016

PAGE No.
800-8

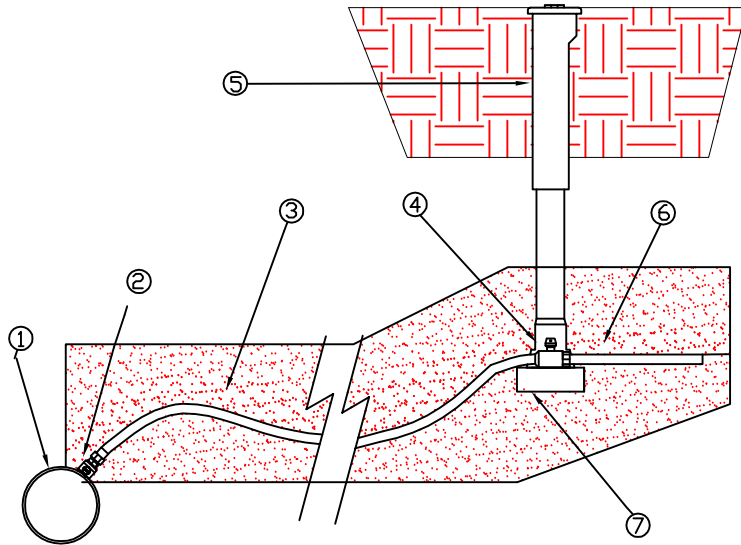

1. WATER MAIN
2. CORPORATION STOP FORD FB-600NL
3. TYPE 1" K-COPPER
4. CURB STOP
5. CURB BOX 2 1/2" 94 E
6. 10' OF 1" SERVICE EXTENSION
7. CONCRETE BLOCK

NOTES:

1. ENSURE CURB BOX IS PLUMB OVER CURB STOP AFTER BACKFILLING AROUND CURB BOX.
2. CURB BOX FLUSH WITH FINAL GRADE.
3. COPPER SERVICE LINE IS BE BEDDED AND COVERED WITH NO LESS THAN 12 INCHES OF SAND.

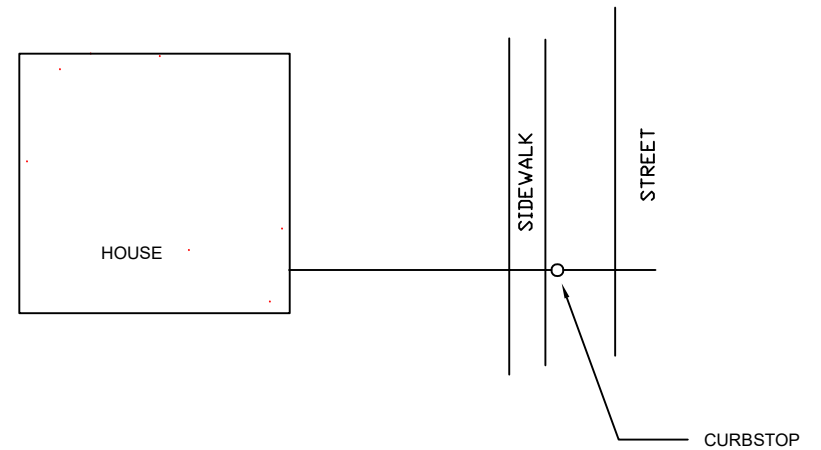

CITY OF PIQUA



CURB STOP ASSEMBLY

REVISIONS:
05-04-18 BG

DATE
APPROVED:
DEC. 2016

PAGE No.
800-8A

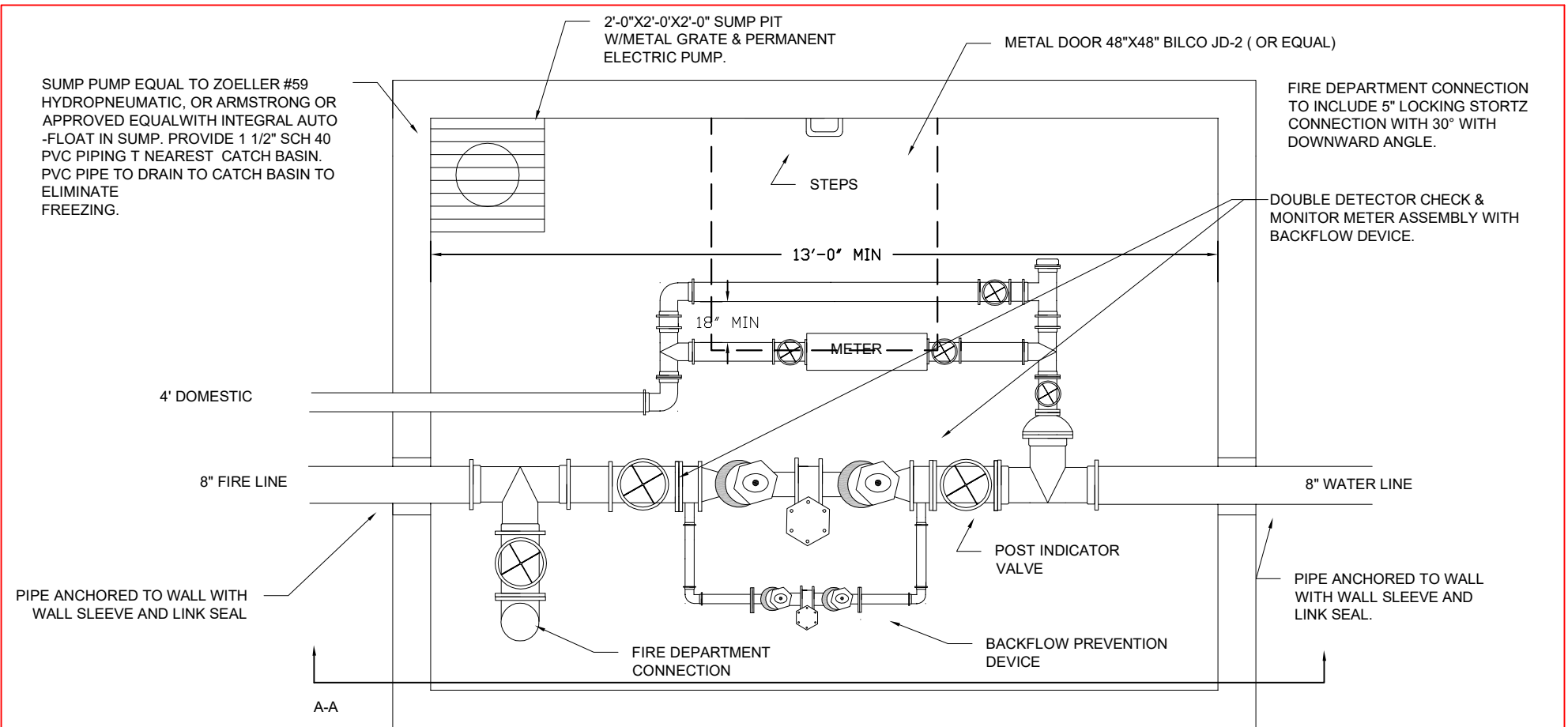

1. PIT SHALL BE MASONRY EITHER PRECAST OR POURED IN PLACE WITH QC1, VAULT WILL HAVE A MINIMUM OF 6'-0" CLEAR HEIGHT.
2. AUTOMATIC SUMP PUMP WITH MINIMUM DISCHARGE OF UP TO 500 GPH IS REQUIRED.
3. STEPS SHALL BE PLASTIC 12" O.C. AS MANUFACTURED BY MA INDUSTRIES (PS1-PF) OR EQUAL.
4. ALL PIPE SHALL HAVE MIN 48" COVER AND MINIMUM 18" FROM FLOOR.
5. NO FIELD SOLDERED JOINTS IN THE PIT.
6. ALL FIRE LINE PIPE SHALL BE D.I. CLASS 51 WITH FLANGED END TO OUTLET VALVE OF DOUBLE DETECTOR CHECK ASSEMBLY.
7. ALL FIRE LINE VALVES SHALL BE FLANGED ENDED, HANDWHEEL OPERATED, RISING STEM OS&Y, OPEN IN SAME DIRECTION AND MUST BE CLOSED RIGHT.
8. AN OEPA APPROVED DOUBLE DETECTOR CHECK VALVE ASSEMBLY SHALL BE FITTED WITH NECESSARY SCH40 BRASS PLUMBING, MANUFACTURER APPROVED DETECTOR CHECK METER, AND OEPA APPROVED BACKFLOW ASSEMBLY. SEE LATEST OEPA BACKFLOW PREVENTION PUBLICATION.
9. ALL DOMESTIC PIPING SHALL BE DCI CL 51 OR BRASS FOR 3" AND LARGER. SAME SIZE DIAMETER BY-PASS REQUIRED ON 2" AND LARGER SERVICE LINES
10. METER SHALL BE SENSUS OMINI C2, FOLLOW RECOMMENDED MANUFACTURERS SPECIFICATIONS OF SIZES BASED ON WATER LINE SIZE.

NOTE;
METER IS 2" AND DOMESTIC LINE IS 4". METER SPREAD SHALL BE 17"

CITY OF PIQUA



COMBINATION FIRE LINE/DOMESTIC WATER METER PIT

REVISIONS:
02-09-17 BG
05-04-18 BG

DATE APPROVED:
DEC. 2016

PAGE No.
800-9

CONTINUED

10. METER FLANGED END MUST BE UNI-FLANGED
11. ALL DOMESTIC VALVES SHALL BE FLANGED END, HAND WHEEL OPERATED, RISING STEM, OS&Y RESILIENT WEDGE GATE TYPE FOR 3" OR LARGER AND FULL PORT BALL WITH PADLOCK WINGS FOR 2" AND SMALLER.
12. DOMESTIC WATER METER SHALL BE SUPPLIED BY THE CONTRACTOR TO BE INSTALLED WITH OTHER PIPING FOR PROPER ALIGNMENT.
13. MONITOR METER MUST BE APPROVED BY CITY, IF NOT PURCHASED FROM THE CITY OF PIQUA. METER MUST READ IN GALLONS AND MUST BE A SENSUS TYPE C-2 METER WITH A T-2 LENGTH.
14. CONTRACTOR TO COORDINATE ALL MATERIALS AND SPECIFICATIONS WITH SHANE JOHNSON (937-778-2018) PRIOR TO CONSTRUCTION.

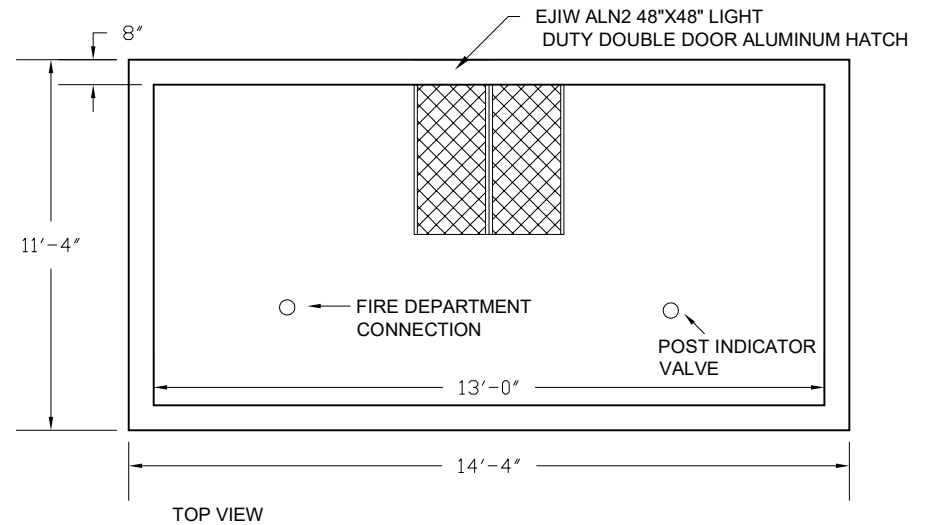
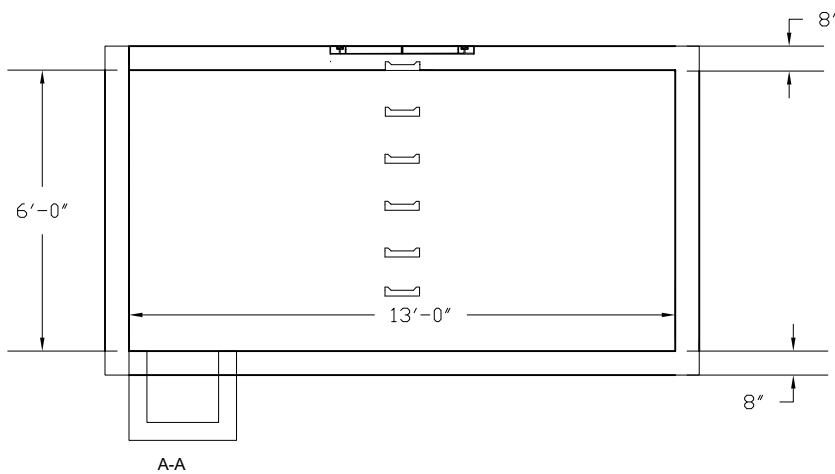

REINFORCEMENT:

BASE SLAB #4 BARS @ C.C.E.W. WITH 1 1/2" COVER TOP LAYER OF QC1 CONCRETE.
 WALLS- #4 BARS @ 12" C.C.E.W. CENTERED IN WALLS
 TOP SLAB- #4 BARS @ 10 C.C.E.W. TOP AND BOTTOM LAYERS WITH 1 1/2" COVER OF QC1 CONCRETE.

NOTES:

1. ALL LINK SEALS ARE TO BE SUPPLIED AND INSTALLED BY CONTRACTOR.
2. HOLE SIZES TO BE 4" LARGER THAN DUCTILE IRON PIPE FOR PROPER LINK SEAL INSTALLATION.

EXISTING DOMESTIC WATER WITH NO BACKFLOW DEVICE REQUIRED

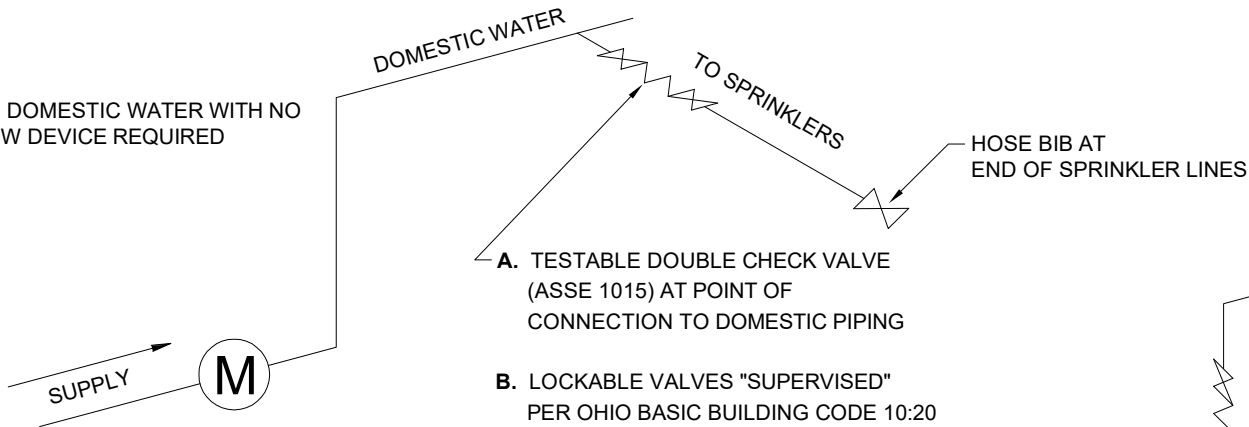

- A. TESTABLE DOUBLE CHECK VALVE (ASSE 1015) AT POINT OF CONNECTION TO DOMESTIC PIPING
- B. LOCKABLE VALVES "SUPERVISED" PER OHIO BASIC BUILDING CODE 10:20
- C. PAST THE SPRINKLER HEADS AT THE END OF THE LINE A HOSE BIB SHALL BE INSTALLED FOR TESTING PURPOSES.

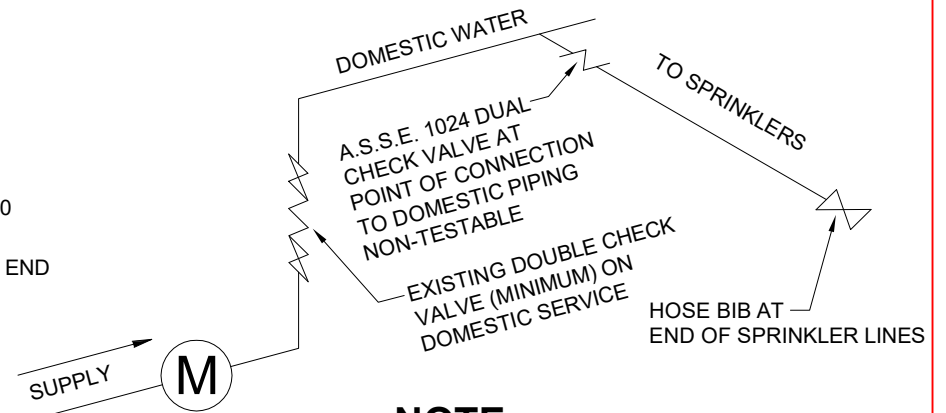

NOTE:

- A. ADDITION OF BACKFLOW DEVICE ONTO EXISTING FIRE SUPPRESSION SYSTEM WILL AFFECT ORIGINAL FLOW CALCULATION

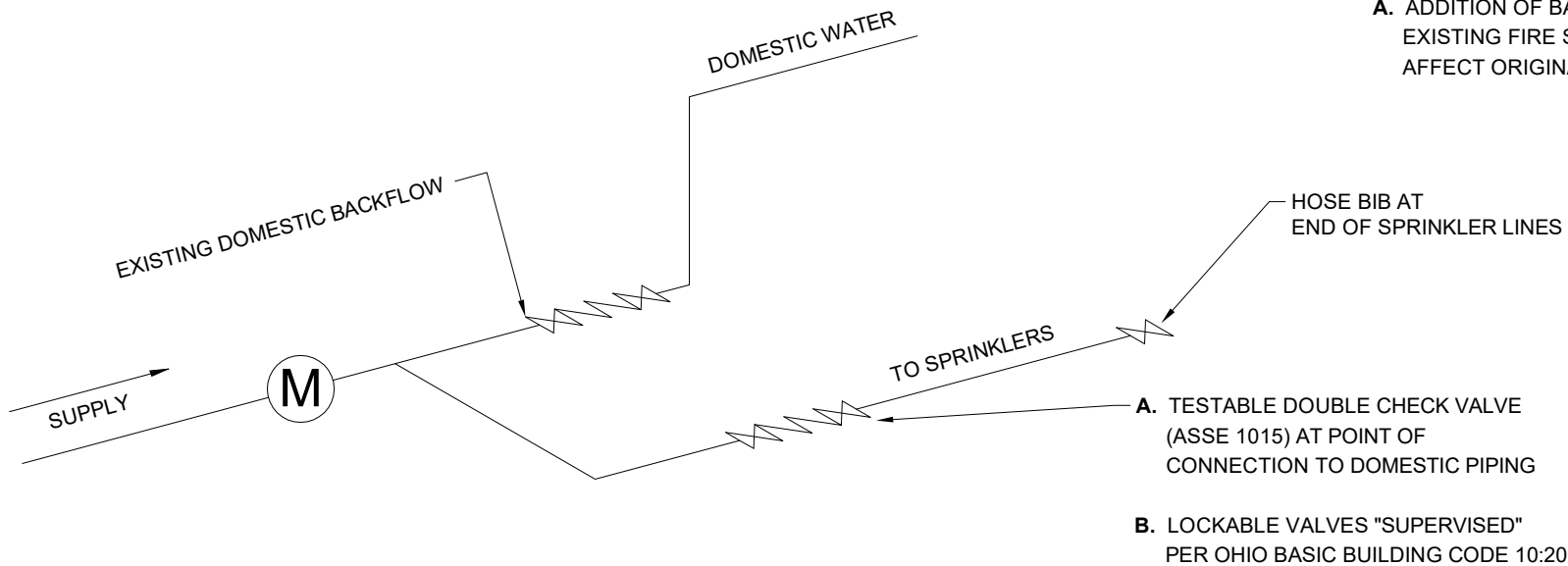

- A. TESTABLE DOUBLE CHECK VALVE (ASSE 1015) AT POINT OF CONNECTION TO DOMESTIC PIPING
- B. LOCKABLE VALVES "SUPERVISED" PER OHIO BASIC BUILDING CODE 10:20

CITY OF PIQUA



LIMITED AREA SPRINKLER SYSTEM DETAIL

REVISIONS:

DATE APPROVED:
DEC. 2016

PAGE No.

02-09-17 BG

800-10

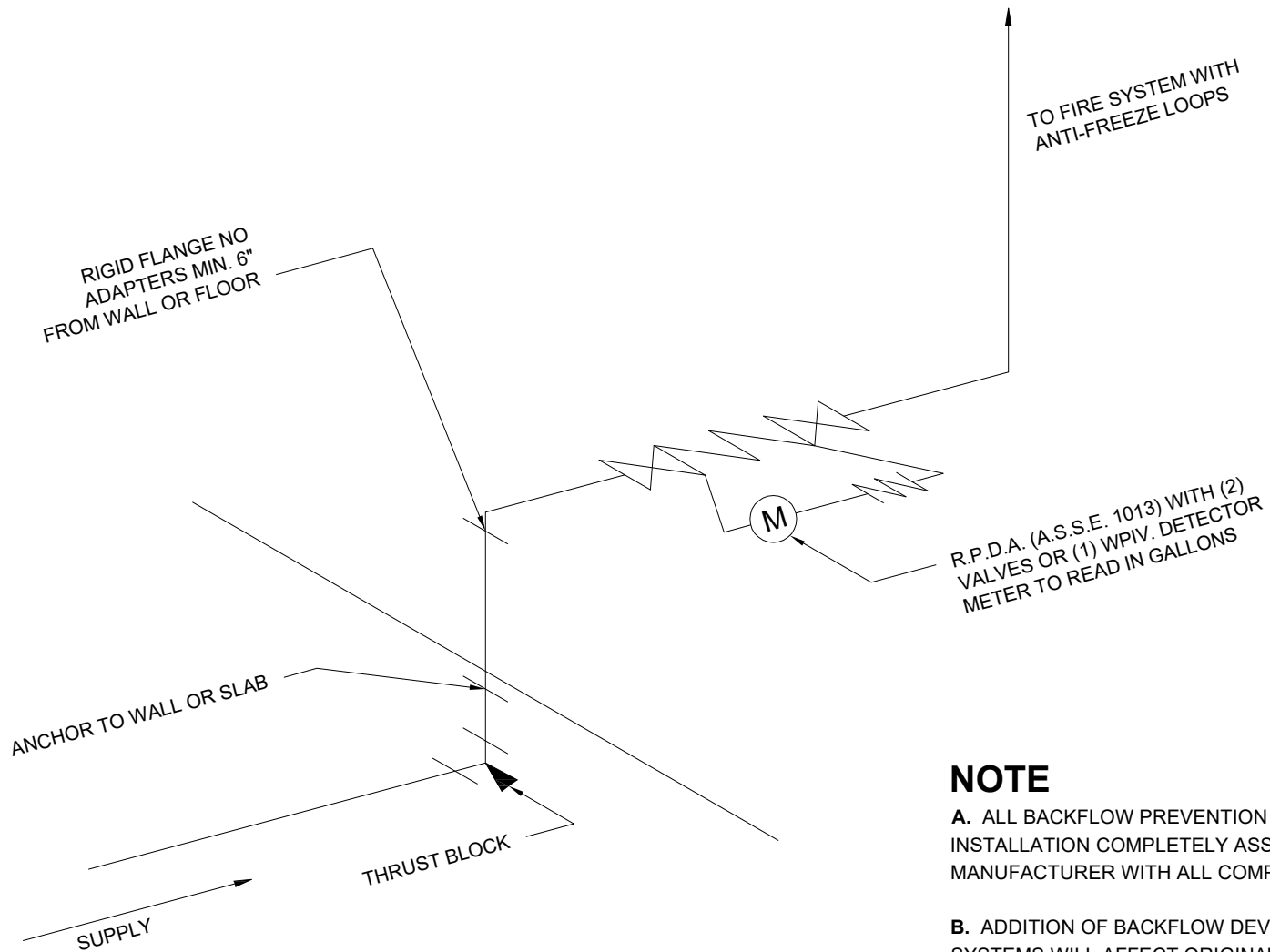

NOTE

- A. ALL BACKFLOW PREVENTION ASSEMBLIES SHALL BE DELIVERED FOR INSTALLATION COMPLETELY ASSEMBLED BY THE ORIGINAL MANUFACTURER WITH ALL COMPONENTS AS APPROVED.
- B. ADDITION OF BACKFLOW DEVICE ONTO EXISTING FIRE SUPPRESSION SYSTEMS WILL AFFECT ORIGINAL FLOW CALCULATIONS.
- C. CLASS 53 DUCTILE IRON TO VALVE. ALL JOINTS RESTRAINED.
- D. BACKFLOW REGULATIONS SHALL BE PER EPA'S CURRENT REGULATIONS.

RIGID FLANGE NO ADAPTERS MIN. 6" FROM WALL OR FLOOR

ANCHOR TO WALL OR SLAB

SUPPLY

THRUST BLOCK

TO FIRE SYSTEM

A.S.S.E. 1015 DOUBLE DETECTOR CHECK VALVE WITH APPROVED INDICATING VALVES. DETECTOR METER TO READ IN GALLONS.

RIGID FLANGE NO ADAPTERS MIN. 6" FROM WALL OR FLOOR

ANCHOR TO WALL OR SLAB

SUPPLY

THRUST BLOCK

FIRE PUMP (TO HAVE LOW SUCTION CUT-OFF)

LOW SUCTION CUT-OFF AS REQUIRED TO MEET OHIO BACKFLOW REGULATIONS

TO FIRE SYSTEM

A.S.S.E. 1015 DOUBLE DETECTOR CHECK VALVE WITH APPROVED INDICATING VALVES. THIS DEVICE MAY BE LOCATED BEFORE THE PUMP WHERE PIPE ENTERS BUILDING WHEN THE PUMP IS SUFFICIENTLY ISOLATED FROM THE CHECK VALVES. DETECTOR METER TO READ IN FEET.

NOTE

A. ALL BACKFLOW PREVENTION ASSEMBLIES SHALL BE DELIVERED FOR INSTALLATION COMPLETELY ASSEMBLED BY THE ORIGINAL MANUFACTURER WITH ALL COMPONENTS AS APPROVED.

B. CLASS 53 DUCTILE IRON TO VALVE. ALL JOINTS RESTRAINED.

C. BACKFLOW REGULATIONS SHALL BE PER EPA'S CURRENT REGULATIONS.

CITY OF PIQUA

ACCESS
Engineering Solutions

DOUBLE DETECTOR CHECK VALVE ASSEMBLY DETAIL

REVISIONS:

02-09-17 BG

DATE
APPROVED:
DEC. 2016

PAGE No.
800-12

NOTES

- A. SEE "STANDARDS FOR TAPS, SERVICES AND METERS" FOR TYPICAL NOTES.
- B. BACKFLOW PREVENTION DEVICE REQUIRED TO MEET CURRENT EPA REGULATIONS.
- C. PROVIDE APPROVED DRAIN FOR IRRIGATION SYSTEM.
- D. ALTERNATE DESIGNS MUST BE SUBMITTED FOR APPROVAL.
- E. THE METER PIT MUST BE BROUGHT UP TO FINISH GRADE.
- F. NO OUTLETS ARE ALLOWED BETWEEN METER AND THE BACKFLOW PREVENTER OR HOSE BIBB VACUUM BREAKER WITH THE EXCEPTION OF ONE SCREW PLUG -IN TAP FOR WINTERIZING/DRAINAGE PURPOSES.
- G. THE UNDERGROUND WATER SERVICE SHALL BE K-COPPER UP TO THE BACKFLOW PREVENTER OR HOSE BIBB VACUUM BREAKER.
- H. THE INSTALLATION SHALL BE INSPECTED BY THE CITY.

INSTRUCTIONS FOR THE INSTALLATION OF IRRIGATION METERS AND BACKFLOW PREVENTERS FOR IRRIGATION SYSTEMS.

- A. MAKE A DRAWING OF THE PROPOSED IRRIGATION SYSTEM, THIS DRAWING IS TO BE APPROVED BY THE CITY.
- B. ALL WORK SHALL BE DONE IN ACCORDANCE WITH THE CITY STANDARDS FOR "TAPS, SERVICES AND METERS".
- C. GET NECESSARY PERMITS.
 - 1. TAPPING PERMIT
- D. THE CONTRACTOR MUST BE REGISTERED WITH THE MIAMI COUNTY HEALTH DEPARTMENT.
 - 1. THE CONTRACTOR MUST OBTAIN A PERMIT TO INSTALL AND PAY ALL APPLICABLE FEES TO THE COUNTY HEALTH DEPARTMENT PRIOR TO INSTALLATION.
 - 2. A PLUMBER WITH AN OHIO LICENSE /BACKFLOW CERTIFICATION MUST BE OBTAINED TO INSTALL AND TEST BACKFLOW DEVICES.
- E. AFTER THE BACKFLOW PREVENTERS HAVE BEEN INSTALLED, PLEASE FILL OUT THE FORMS COMPLETELY WITH THE OWNER/LEASE HOLDER'S, ADDRESS (WHERE THE BACKFLOW PREVENTER WAS INSTALLED) , LOCATION OF THE BACKFLOW PREVENTER , SIZE, MAKE, MODEL TEST RESULTS BY A LICENCED PLUMBER, ANNUAL TEST RESULTS THERE AFTER, AND SERIAL NUMBER OF THE BACKFLOW PREVENTER. PLEASE RETURN THE COMPLETED FORMS TO THE CITY AND MIAMI COUNTY HEALTH DEPARTMENT.
- F. CONTACT THE CITY UNDERGROUND UTILITY DEPARTMENT AFTER THE WORK HAS BEEN COMPLETED. BACKFLOW PREVENTERS HAVE TO BE INSPECTED BY THE CITY.
- G. SEPARATE VALVES, ONE BEFORE AND AFTER, MUST BE PLACED NEAR THE BACKFLOW PREVENTER WHENEVER THE EXISTING BACKFLOW IS REMOVED.

HOSE BIBB

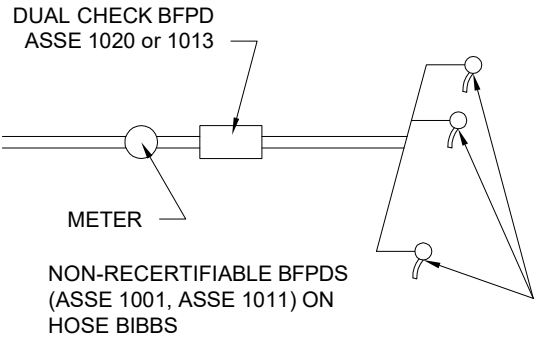

YARD HYDRANT

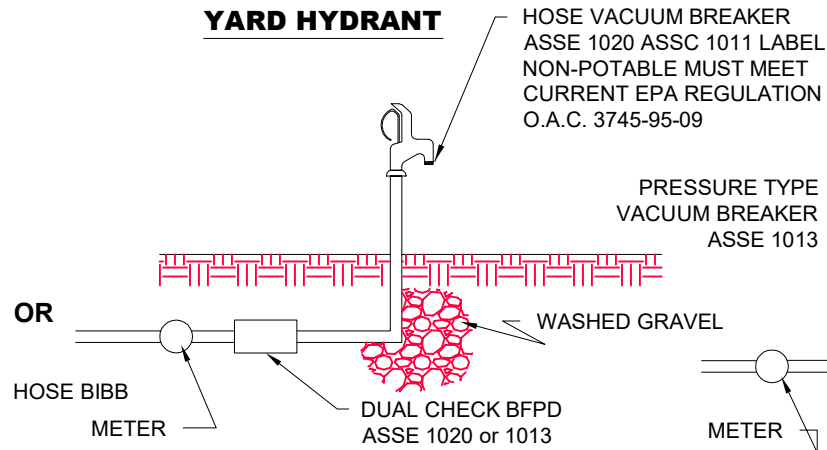

SPRINKLER SYSTEM

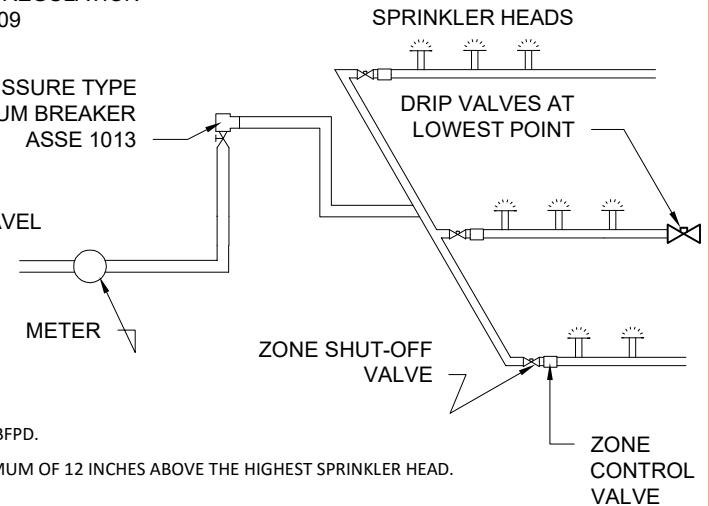

YARD MAIN SYSTEM ARRANGEMENT

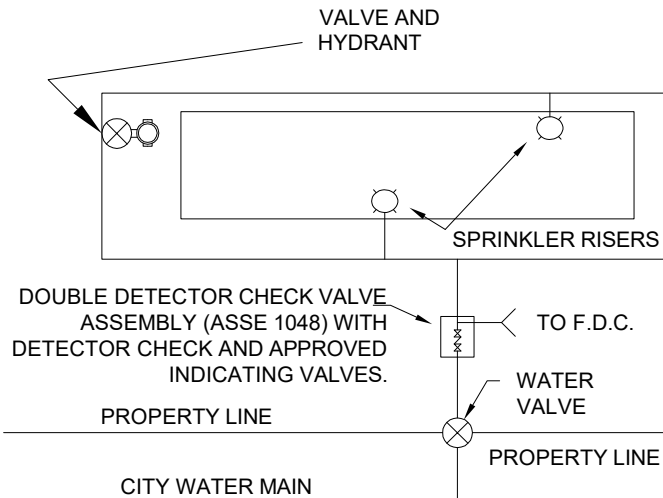

CONDITIONS

- A. SHUT-OFF VALVES ARE ALLOWED DOWNSTREAM OF THE BFPD.
- B. THE PRESSURE TYPE VACUUM BREAKER MUST BE A MINIMUM OF 12 INCHES ABOVE THE HIGHEST SPRINKLER HEAD.

NOTES

- A. SEE "STANDARDS FOR TAPS, SERVICES AND METERS" FOR TYPICAL NOTES.
- B. BACKFLOW PREVENTION DEVICE IS REQUIRED TO MEET CURRENT EPA REGULATIONS.
- C. PROVIDE APPROVED DRAIN FOR IRRIGATION SYSTEM.
- D. ALTERNATE DESIGNS MUST BE SUBMITTED FOR APPROVAL.
- E. THE CURB BOX MUST BE BROUGHT UP TO FINISH GRADE.
- F. NOT OUTLETS ARE ALLOWED BETWEEN METER AND THE BACKFLOW PREVENTER OR HOSE BIBB VACUUM BREAKER WITH THE EXCEPTION OF ONE SCREW PLUG-IN TAP FOR WINTERIZING/DRAINAGE PURPOSES.
- G. THE UNDERGROUND WATER SERVICE SHALL BE K-COPPER UP TO THE BACKFLOW PREVENTER OR HOSE BIBB VACUUM BREAKER.
- H. THE INSTALLATION SHALL BE INSPECTED BY THE CITY.

REQUIREMENTS FOR YARD HYDRANTS (O.A.C 3745-95-09)

- A. YARD HYDRANTS WITH WEEP HOLES ARE PROHIBITED
- B. SANITARY YARD HYDRANTS THAT DO NOT HAVE WEEP HOLES, SUCH AS THOSE THAT MEET THE REQUIREMENTS OF THE "AMERICAN SOCIETY OF SANITARY ENGINEERS (ASSE) STANDARD 1057", PERFORMANCE REQUIREMENTS FOR FREEZE RESISTANT YARD HYDRANTS WITH BACKFLOW PROTECTION (2001).

ARE NOT PROHIBITED PROVIDED:

- 1) THE DEVICE IS ACCEPTABLE TO THE PUBLIC WATER SYSTEM TO WHICH IT WILL BE CONNECTED.
- 2) ALL OF THE BACKFLOW AND CROSS-CONNECTION REQUIREMENTS OF THIS CHAPTER OF THE ADMINISTRATIVE CODE ARE MET .

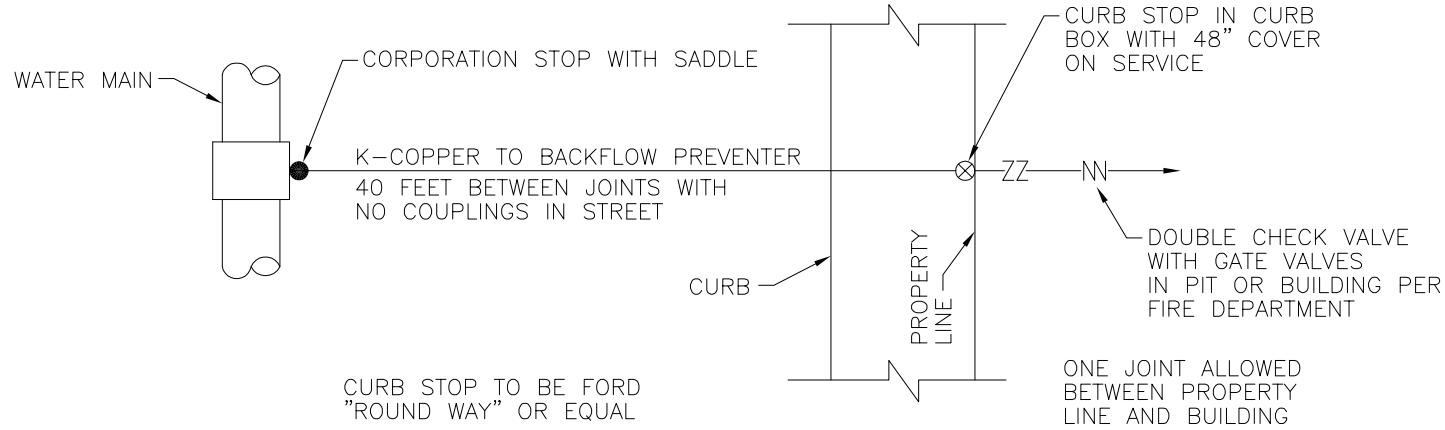

2" FIRE LINE SERVICE
(METER REQUIRED)

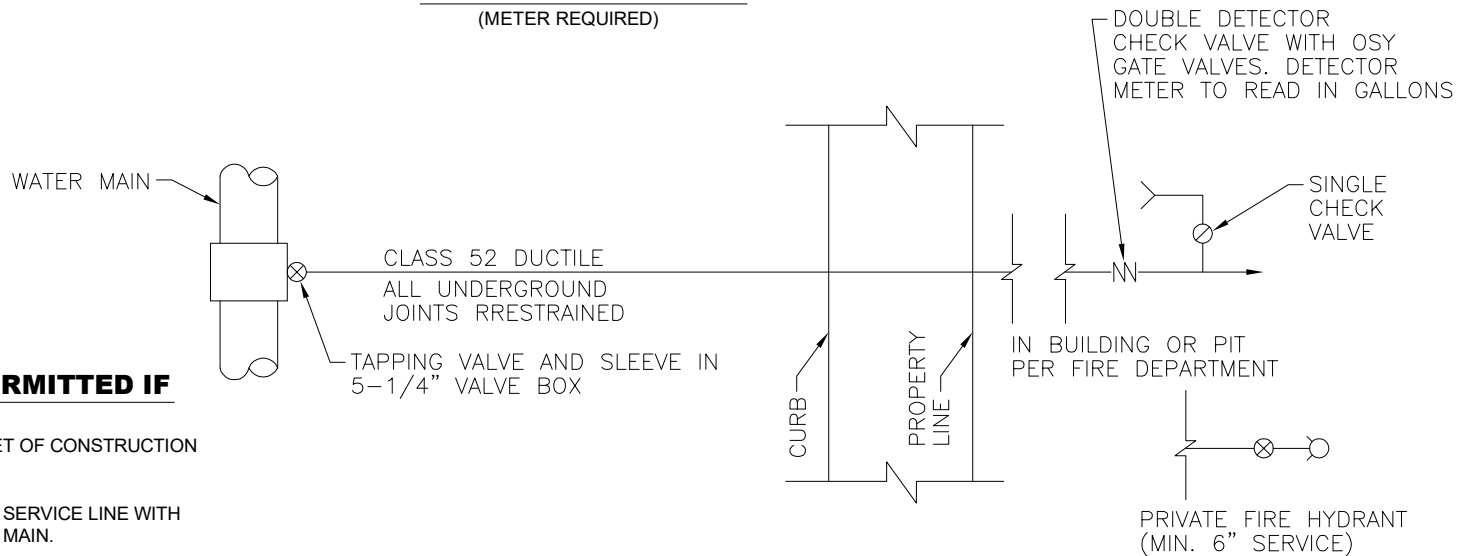

4" AND LARGER FIRE LINE SERVICE
(METER REQUIRED)

WALL/POST INDICATOR VALVES SHALL BE ADDED ON PREMISES AT FIRE DEPARTMENT REQUEST

SERVICE TEES ARE PERMITTED IF

- A. SHOWN ON AND APPROVED SET OF CONSTRUCTION DRAWINGS.
- B. 4 INCH MINIMUM BRANCH AND SERVICE LINE WITH GATE VALVE WITHIN 3 FEET OF MAIN.
- C. 6 INCH FIRE LINE MAY HAVE A ONE-INCH DOMESTIC TAP AND 8 INCH FIRE LINE MAY HAVE A 2 INCHES DOMESTIC TAP. ALL DOMESTIC TAPS MUST BE INSTALLED BEFORE THE FIRE SPRINKLER RISER.

CITY OF PIQUA



**2" FIRE LINE AND
4" AND LARGER FIRE LINE**

REVISIONS:

DATE
APPROVED:
DEC. 2016

PAGE No.
800-15

02-09-17 BG

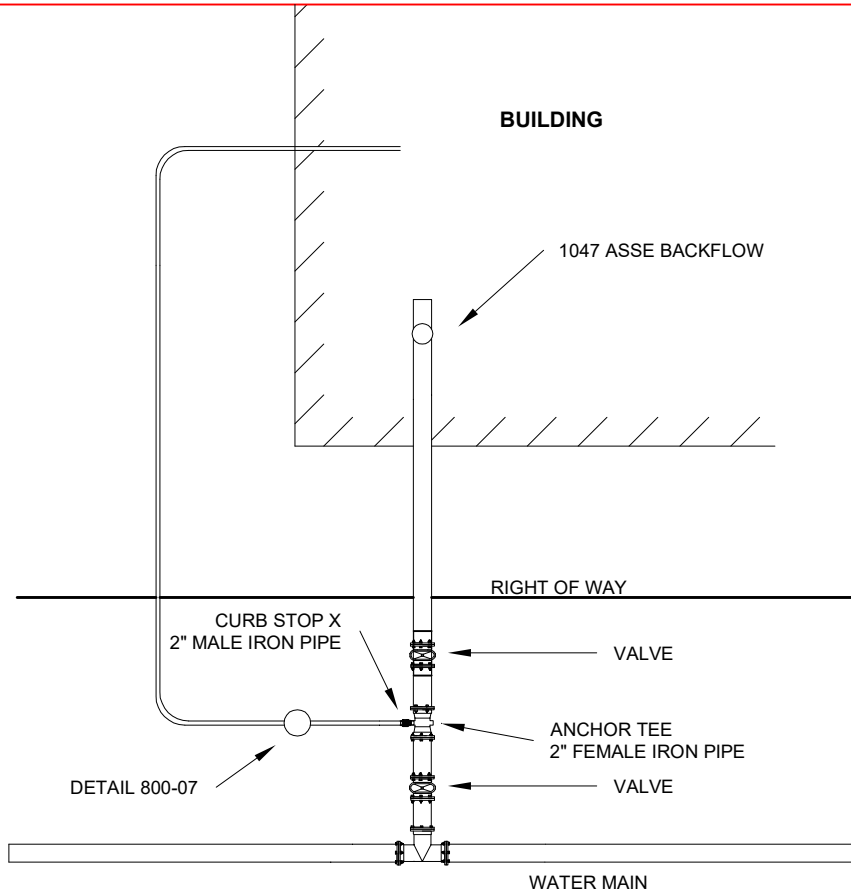

REVIEW AND FEES

A. FIVE SETS OF SITE PLANS SHALL BE SUBMITTED TO THE CITY UNDERGROUND UTILITY DEPARTMENT TO BE REVIEWED. FIRE DEPARTMENT, ELECTRICAL DISTRIBUTION, CITY ENGINEER, AND THE PLANNING COORDINATOR WILL REVIEW PLANS.

TESTING

A. THE CITY FIRE DEPARTMENT PERSONNEL WILL CONDUCT SELECTIVE FIRE HYDRANT TESTING FOR RESIDUAL PRESSURE. THE TESTING IS DONE ANNUALLY OR WHENEVER NEEDED. PROCEDURES OF THE HYDRANT FLOW TEST ARE FOLLOWED FROM THE FOURTH EDITION OF THE IFSTA MANUAL "WATER SUPPLIES FOR FIRE PROTECTION". TESTING PROCEDURES ARE ON FILE AT THE MAIN FIRE STATION . ALSO SEE PAGE 800-5

GENERAL NOTES

- A. FIRE LINE AND HYDRANT INSTALLATION, TESTING AND MATERIALS SHALL BE THE SAME SPECIFICATIONS AS STATED IN THE CONSTRUCTION STANDARDS AND DRAWINGS. THESE CONSTRUCTION STANDARDS AND DRAWINGS SHALL ALSO BE FOLLOWED FOR WATERLINE EXTENSIONS ON PRIVATE PROPERTY THAT WILL PROVIDE FIRE LINE OR DOMESTIC WATER SERVICE.
- B. CITY OF PIQUA LINE REVIEW FORMS SHALL BE COMPLETED WITH TWO SETS OF PLANS FURNISHED TO THE CITY UNDERGROUND UTILITIES DEPARTMENT.
- C. CITY OF CERTIFIED I.S.O. TEST SHALL BE NOT BE CERTIFIED TO THE STATE OF OHIO UNTIL THE FOLLOWING ITEMS HAVE BEEN COMPLETED.
 - 1. ONE SET OF DRAWINGS FURNISHED TO THE ENGINEERING DEPARTMENT.
 - 2. FIRE LINE INSTALLATION FORM SHALL BE COMPLETE .
- D. NO ADDITIONAL BOOSTER PUMPS SHALL BE INSTALLED FOR THE DOMESTIC LINE.

ALL MAINTENANCE SHOULD COMPLY WITH THE MOST CURRENT OHIO FIRE CODE AND NFPS 25.

- E. FIRE LINE MAINTENANCE SHALL BE PERFORMED BY A CERTIFIED FIRE LINE CONTRACTOR THROUGH THE OFFICE OF THE STATE FIRE MARSHALL.
- F. TESTING OF FIRE LINES SHALL BE PERFORMED BY A STATE APPROVED FIRE LINE INSTALLER.
- E. A CERTIFIED FIRE LINE CONTRACTOR LICENSED THROUGH THE OFFICE OF THE STATE FIRE MARSHALL SHALL PERFORM THE WORK.

SPRINKLER NOTES

- A. SUBMIT TO; MIAMI COUNTY BUILDING REGULATIONS DEPARTMENT
- B. HYDRAULIC CALCULATIONS FROM THE SPRINKLER SYSTEM DESIGNER SHALL BE SUBMITTED TO THE FIRE DEPARTMENT, WITH SITE PLAN FOR REVIEW.
- C. INSTALLATION OF A FLOW SENSOR MONITOR WILL BE REQUIRED TO REPORT TO AN APPROVED MONITORING SYSTEM. (I.E. POLICE, PRIVATE STATION)
- D. THERE SHALL BE AN EXISTING OR NEW HYDRANT INSTALLED WITHIN 100 FEET OF THE SIAMESE CONNECTION AND NO CLOSER THAN 25 FEET OF A BUILDING. EXCEPTIONS MUST BE SUBMITTED TO THE CITY FIRE PROTECTION OFFICIALS.
- E. A 6 INCH FIRE LINE MAY HAVE A ONE-INCH MAXIMUM DOMESTIC TAP AND AN 8 INCH FIRE LINE MAY HAVE A 2 INCH MAXIMUM DOMESTIC TAP. ALL DOMESTIC TAPS MUST BE INSTALLED BEFORE THE FIRE SPRINKLER RISER.

NOTES

- A. THE FIRE LINE SHALL BE DEFINED AS " THE LINE FROM THE RISER INSIDE THE BUILDING TO THE FIRST VALVE ON THE SYSTEM"
- B. MINIMUM FIRE LINE SIZE SHALL BE 6 INCHES
- C. A 1 INCH DOMESTIC TAP CAN BE MADE ON A 6 INCH FIRE LINE AND A 2 INCH DOMESTIC TAP ON A 8 INCH FIRE LINE. TAP MUST BE MADE PRIOR TO BACKFLOW PREVENTOR.
- D. A FIRE HYDRANT SHALL BE INSTALLED WITH 100 FEET OF THE STORTZ CONNECTION.
- E. FIRE LINE CHANGES SHALL BE BASED ON SIZE OF RISER.
- F. CONTRACTOR SHALL INSTALL A REDUCED PRESSURE PRINCIPLE BACKFLOW PREVENTER ON FIRE LINE PRIOR TO RISER.
- G. LIMITED AREA SPRINKLERS SHALL BE CONNECTED BEFORE METER.
- H. DOMESTIC SERVICE SHALL INCLUDE BACKFLOW PREVENTOR PRIOR TO METER. WATER METER SHALL HAVE A BYPASS AND STRAINER.
- I. ALL MATERIAL AND CONSTRUCTION METHODS SHALL CONFORM TO THE CITY STANDARDS.
- J. PRIVATE WATER MAIN SHALL REMAIN PRIVATE UNLESS ACCEPTED BY THE CITY AND AN EASEMENT IS GRANTED.
- K. ALL FIRE LINES SHALL BE TESTED AT 200 PSI . SEE HYDROSTATIC TEST ON PAGE 800-5 FOR ADDITIONAL REQUIREMENTS. FIRE DEPARTMENT OR THE UNDERGROUND UTILITIES DEPARTMENT IS TO WITNESS THE TEST.

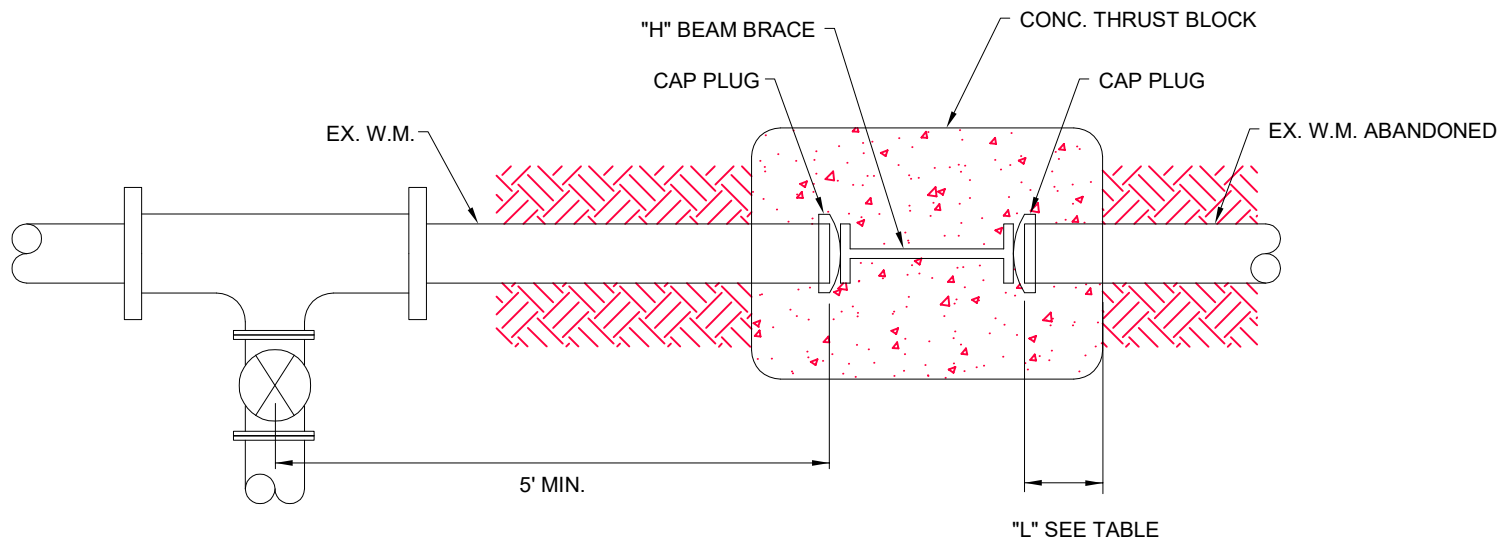

DIA.	4"	6"	8"	10"	12"	16"	20"	24"
"L"	12	26	38	48	66	98	125	145

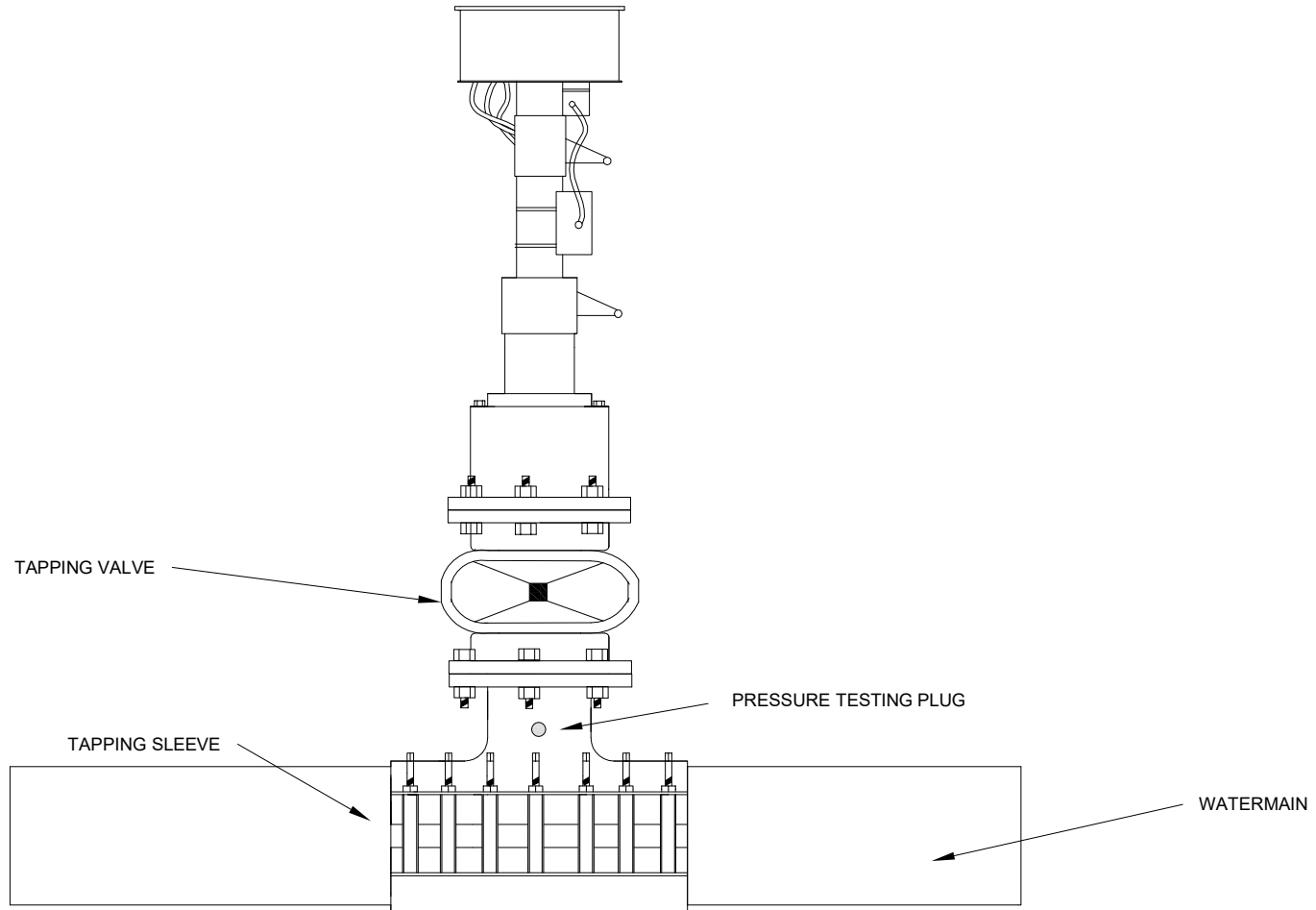

- THE PRESURE TEST SHALL BE PERFORMED UNDER THE DIRECT SUPERVISION OF THE CITY OF PIQUA UNDERGROUND UTILITIES REPRESENTATIVE.
- THE TEST SHALL BE FOR FIVE (5) MINUTES AT 150PSI FOR CAST IRON PIPE AND 200PSI DUCTILE IRON PIPE.
- FOLLOW MANUFACTURES RECOMMENDATIONS FOR TORQUE SETTINGS ON TAPPING SLEEVE.

CITY OF PIQUA

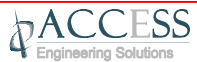

TAPPING SLEEVE AND VALVE HYDROSTATIC TEST

REVISIONS:

DEC. 2016
DATE
APPROVED:

PAGE No.
800-19

900 – Sanitary Sewers

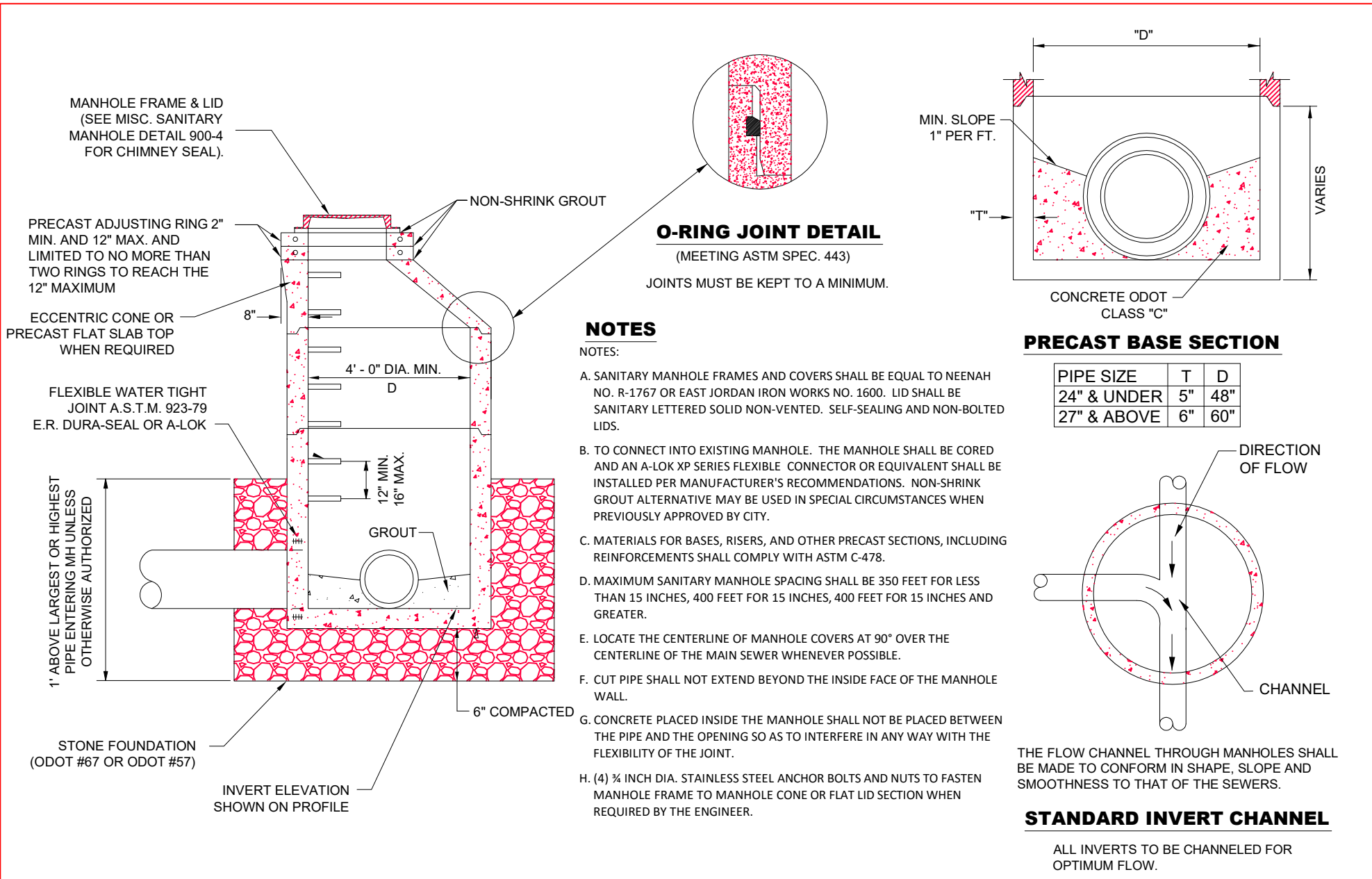

MANHOLE FRAME & LID
(SEE MISC. SANITARY
MANHOLE DETAIL 900-4
FOR CHIMNEY SEAL).

PRECAST ADJUSTING RING 2"
MIN. AND 12" MAX. AND
LIMITED TO NO MORE THAN
TWO RINGS TO REACH THE
12" MAXIMUM

ECCENTRIC CONE OR
PRECAST FLAT SLAB TOP
WHEN REQUIRED

FLEXIBLE WATER TIGHT
JOINT A.S.T.M. 923-79
E.R. DURA-SEAL OR A-LOK

1' ABOVE LARGEST OR HIGHEST
PIPE ENTERING MH UNLESS
OTHERWISE AUTHORIZED

STONE FOUNDATION
(ODOT #67 OR ODOT #57)

INVERT ELEVATION
SHOWN ON PROFILE

NON-SHRINK GROUT

O-RING JOINT DETAIL
(MEETING ASTM SPEC. 443)
JOINTS MUST BE KEPT TO A MINIMUM.

NOTES

- NOTES:
- A. SANITARY MANHOLE FRAMES AND COVERS SHALL BE EQUAL TO NEENAH NO. R-1767 OR EAST JORDAN IRON WORKS NO. 1600. LID SHALL BE SANITARY LETTERED SOLID NON-VENTED. SELF-SEALING AND NON-BOLTED LIDS.
 - B. TO CONNECT INTO EXISTING MANHOLE. THE MANHOLE SHALL BE CORED AND AN A-LOK XP SERIES FLEXIBLE CONNECTOR OR EQUIVALENT SHALL BE INSTALLED PER MANUFACTURER'S RECOMMENDATIONS. NON-SHRINK GROUT ALTERNATIVE MAY BE USED IN SPECIAL CIRCUMSTANCES WHEN PREVIOUSLY APPROVED BY CITY.
 - C. MATERIALS FOR BASES, RISERS, AND OTHER PRECAST SECTIONS, INCLUDING REINFORCEMENTS SHALL COMPLY WITH ASTM C-478.
 - D. MAXIMUM SANITARY MANHOLE SPACING SHALL BE 350 FEET FOR LESS THAN 15 INCHES, 400 FEET FOR 15 INCHES, 400 FEET FOR 15 INCHES AND GREATER.
 - E. LOCATE THE CENTERLINE OF MANHOLE COVERS AT 90° OVER THE CENTERLINE OF THE MAIN SEWER WHENEVER POSSIBLE.
 - F. CUT PIPE SHALL NOT EXTEND BEYOND THE INSIDE FACE OF THE MANHOLE WALL.
 - G. CONCRETE PLACED INSIDE THE MANHOLE SHALL NOT BE PLACED BETWEEN THE PIPE AND THE OPENING SO AS TO INTERFERE IN ANY WAY WITH THE FLEXIBILITY OF THE JOINT.
 - H. (4) ¾ INCH DIA. STAINLESS STEEL ANCHOR BOLTS AND NUTS TO FASTEN MANHOLE FRAME TO MANHOLE CONE OR FLAT LID SECTION WHEN REQUIRED BY THE ENGINEER.

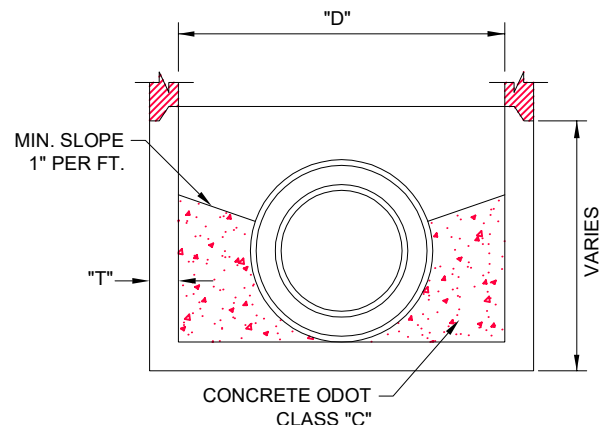

PRECAST BASE SECTION

PIPE SIZE	T	D
24" & UNDER	5"	48"
27" & ABOVE	6"	60"

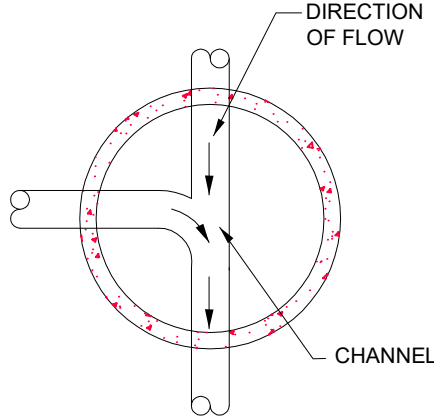

THE FLOW CHANNEL THROUGH MANHOLES SHALL BE MADE TO CONFORM IN SHAPE, SLOPE AND SMOOTHNESS TO THAT OF THE SEWERS.

STANDARD INVERT CHANNEL

ALL INVERTS TO BE CHanneled FOR OPTIMUM FLOW.

"A"	"B"
8", 10", & 12"	8"
15" & 18"	10"
21" & 24"	12"

DROP CONNECTION MANHOLE

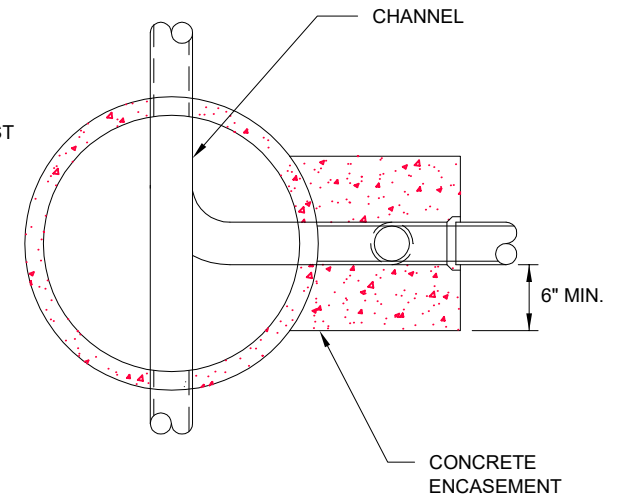
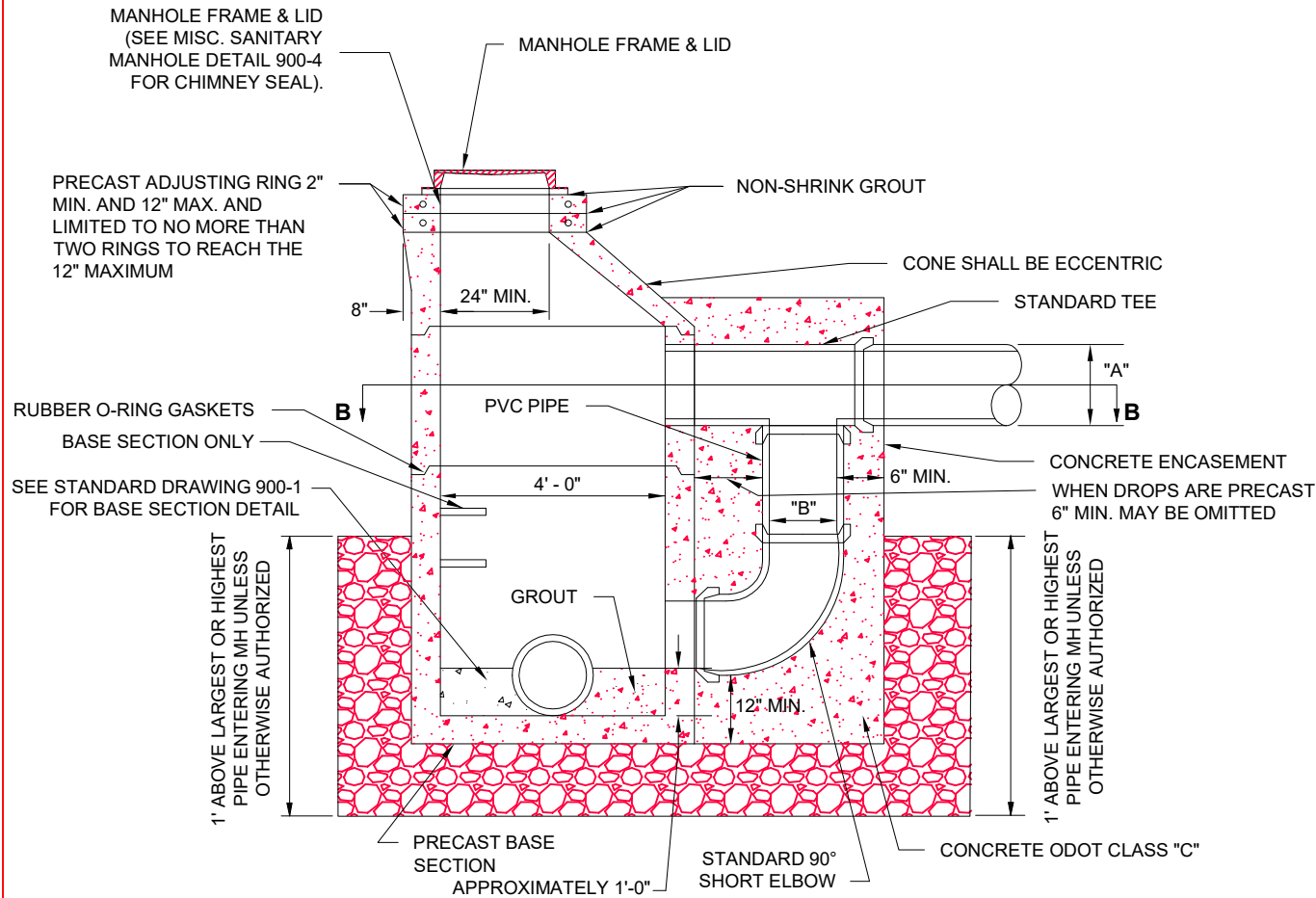

SECTION B-B

NOTES

A. LOCATE THE CENTERLINE OF MANHOLE COVERS AT 90° OVER THE CENTERLINE OF THE MAIN SEWER WHENEVER POSSIBLE.

B. TYPE D MANHOLE SHALL BE USED WHERE THE DIFFERENCE IN INVERT ELEVATIONS IS GREATER THAN 2 FEET.

C. ALL NOTES AND ASTM REFERENCES ON THE TYPE 3 SANITARY MANHOLE SHALL APPLY ON THE TYPE D SANITARY DROP MANHOLE.

CITY OF PIQUA



TYPE 2 SANITARY DROP MANHOLE

REVISIONS:

DATE APPROVED:
DEC. 2016

PAGE No.
900-2

12-28-16 BG

MANHOLE FRAME & LID
(SEE MISC. SANITARY
MANHOLE DETAIL 900-4
FOR CHIMNEY SEAL).

MANHOLE FRAME & LID

PRECAST ADJUSTING RING 2"
MIN. AND 12" MAX. AND
LIMITED TO NO MORE THAN
TWO RINGS

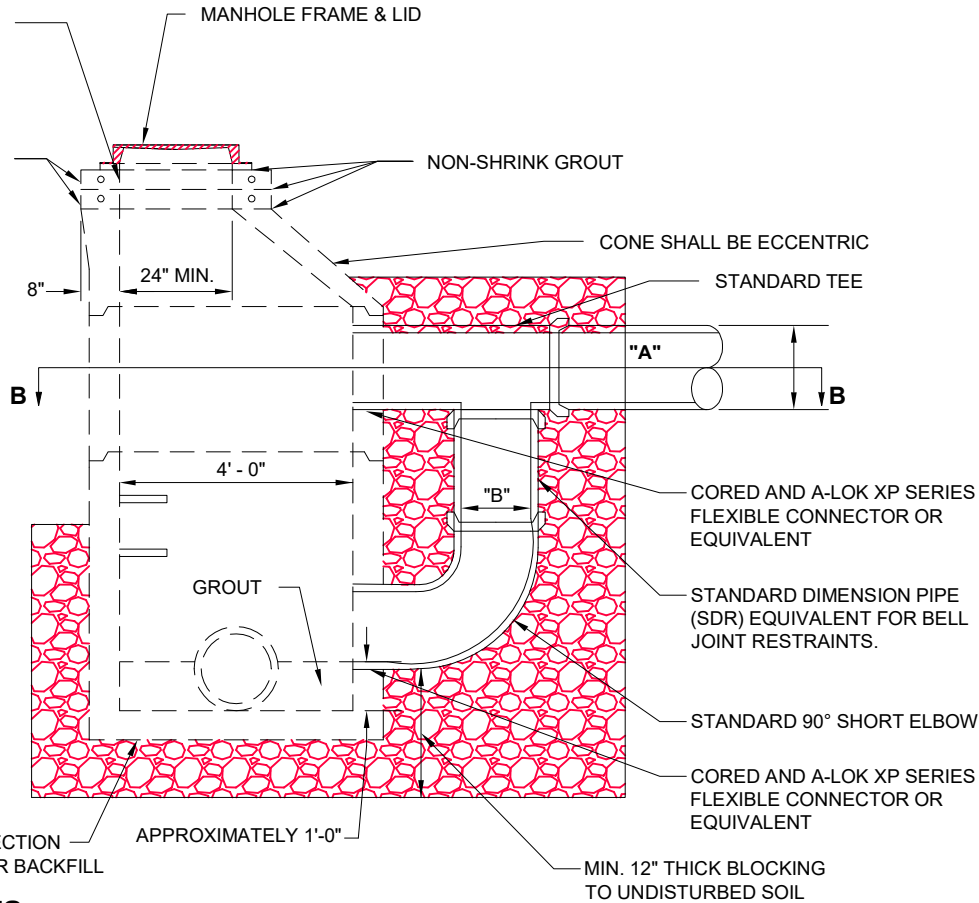

"A"	"B"
8", 10", & 12"	8"
15" & 18"	10"
21" & 24"	12"

DROP CONNECTION MANHOLE

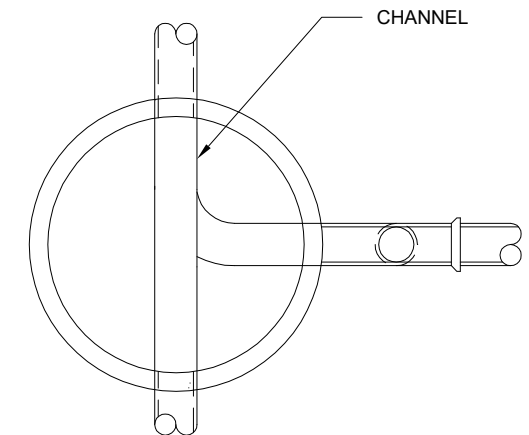

SECTION B-B

NOTES

- A. SANITARY DROP MANHOLE SHALL BE USED WHERE THE DIFFERENCE IN INVERT ELEVATIONS IS GREATER THAN 2 FEET.
- B. ALL NOTES AND ASTM REFERENCES ON THE TYPE 3 SANITARY MANHOLE SHALL APPLY ON THE SANITARY DROP ON EXISTING MANHOLE.
- C. ALL NOTES AND ASTM REFERENCES ON THE TYPE D SANITARY DROP MANHOLE SHALL APPLY ON THE SANITARY DROP ON EXISTING MANHOLE.
- D. STANDARD DIMENSION PIPE (SDR) SHALL BE ANCHORED TO THE OUTSIDE OF THE EXISTING MANHOLE. 3/4 INCH STAINLESS STEEL STRAPPING WITH 24 INCHES ON CENTER WITH STAINLESS ANCHORING.

CITY OF PIQUA



SANITARY DROP ON EXISTING MANHOLE

REVISIONS:

DATE
APPROVED:
DEC. 2016

12-28-16 BG

PAGE No.
900-3

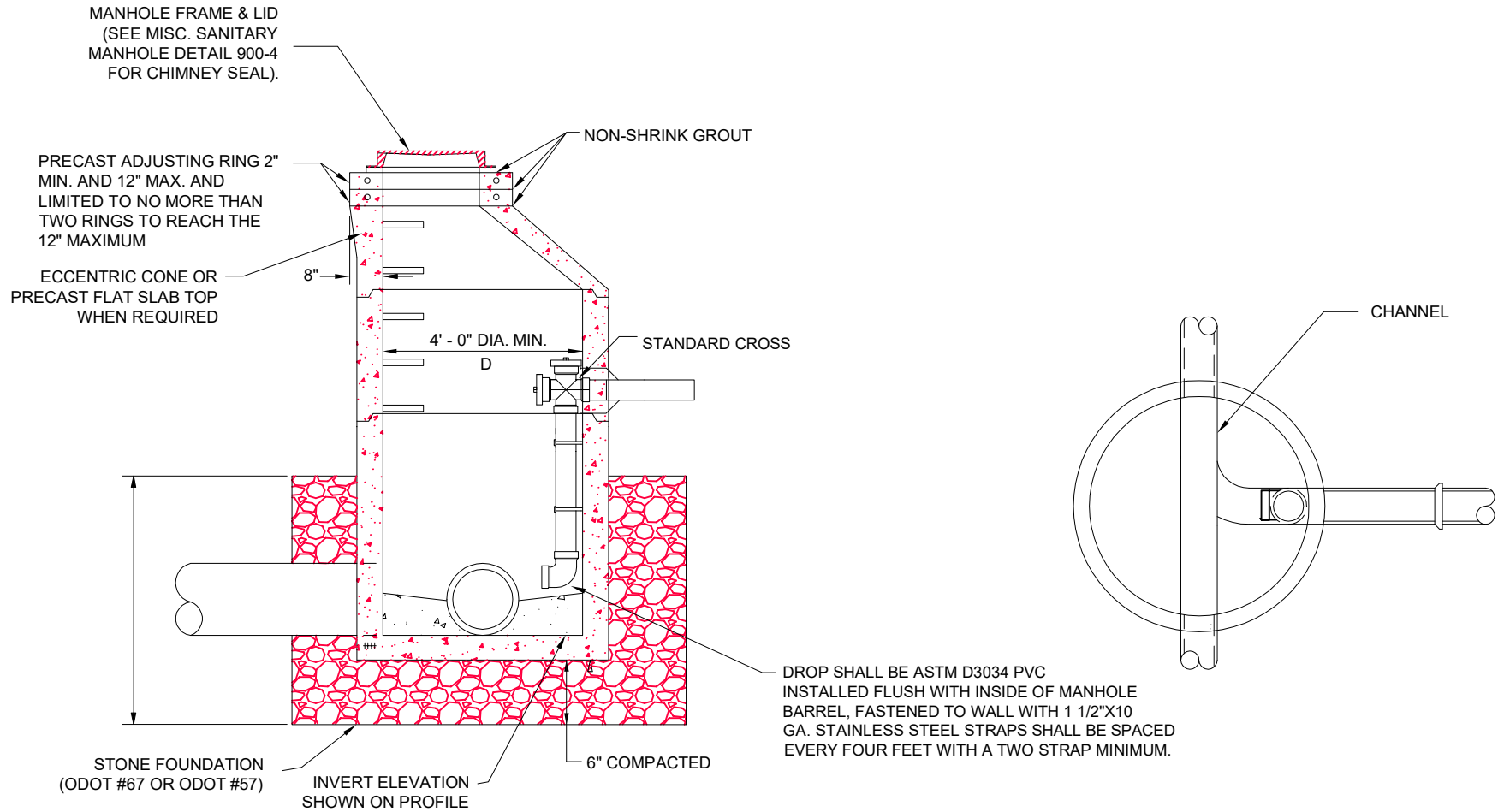

NOTES

1. THE USE OF INSIDE DROP MANHOLES WILL REQUIRE APPROVAL OF THE CITY ENGINEER. THE USE OF INSIDE DROP MANHOLES WILL BE LIMITED TO ONLY SINGLE FAMILY AND MULTI-FAMILY RESIDENCES FOR CONNECTIONS TO EXISTING DEEP SANITARY SEWER SYSTEMS. NOT APPLICABLE TO COMMERCIAL OR INDUSTRIAL APPLICATIONS.
2. ONLY ONE INSIDE DROP CONNECTION ALLOWED PER MANHOLE. PIPE INVERT ELEVATIONS SHALL BE AS SHOWN ON THE PLANS.
3. MINIMUM MANHOLE DIAMETER WITH INSIDE DROP CONNECTION SHALL BE 48 INCHES.
4. MAXIMUM DROP PIPE DIAMETER SHALL BE 6 INCHES.
5. DROP MUST BE OPPOSITE OF THE LADDER STEPS.

CITY OF PIQUA



SANITARY MANHOLE INSIDE DROP

REVISIONS:

DATE
APPROVED:
DEC. 2016

PAGE No.
900-3A

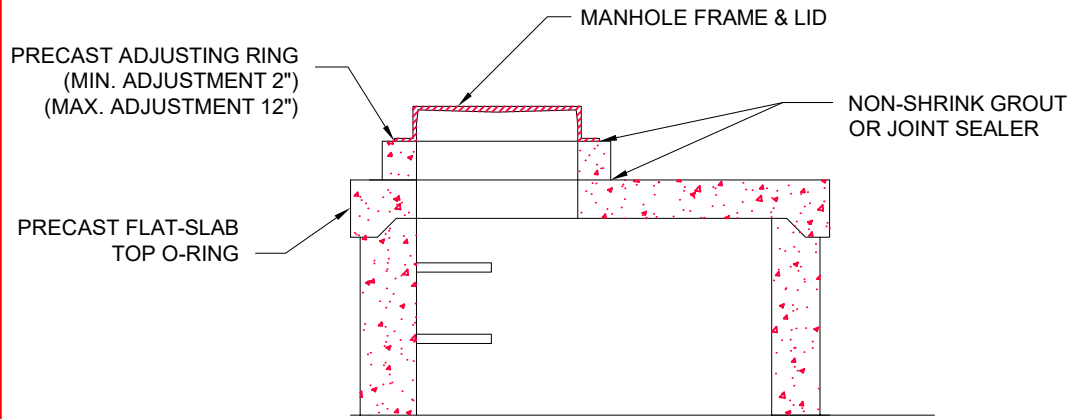

FLAT TOP SLAB

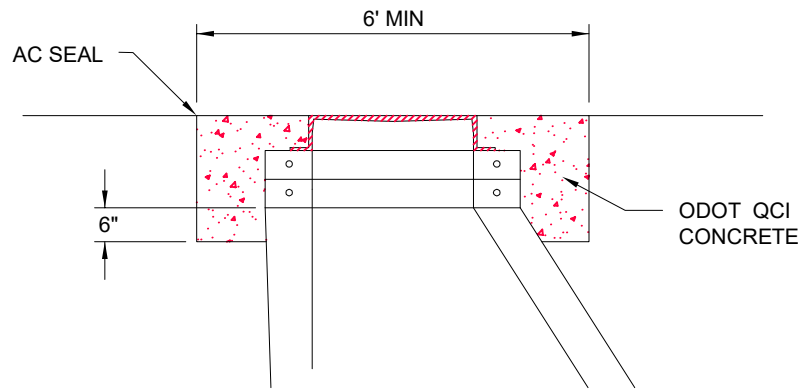

MANHOLE REPAIR CASTING CONSTRUCTION

NOTES

1. PRECAST CONCRETE ADJUSTING RINGS-ENCASE WITH CONCRETE 6 INCHES DOWN FROM BARREL TOP AND UP TO THE PAVEMENT SURFACE.
2. SET MANHOLE, PRECAST CONCRETE ADJUSTING RINGS AND CASTING AND PAVE OVER MANHOLE, THEN DIG OUT. ENCASE COLLARS AND CASTING AS PER DETAIL WITH CONCRETE.

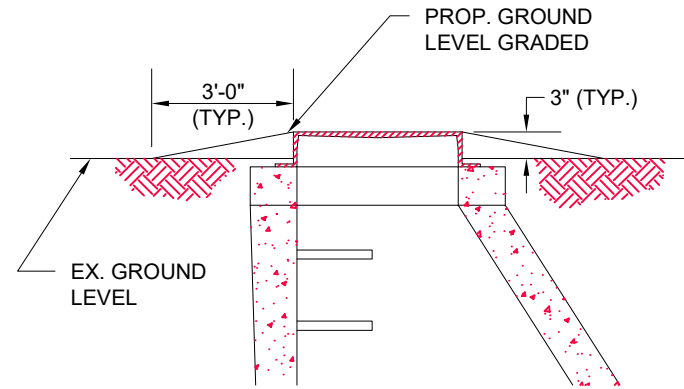

TYPICAL OFF STREET MANHOLE GRADING

NOTES

- A. MANHOLE STEPS SHALL BE SECURELY INSTALLED INTO EACH MANHOLE SECTION, BY THE MANUFACTURER, PRIOR TO DELIVERY TO THE JOB SITE.
- B. MANHOLE STEPS SHALL BE PF-1 STEP BY M.A. INDUSTRIES OR EQUIVALENT.

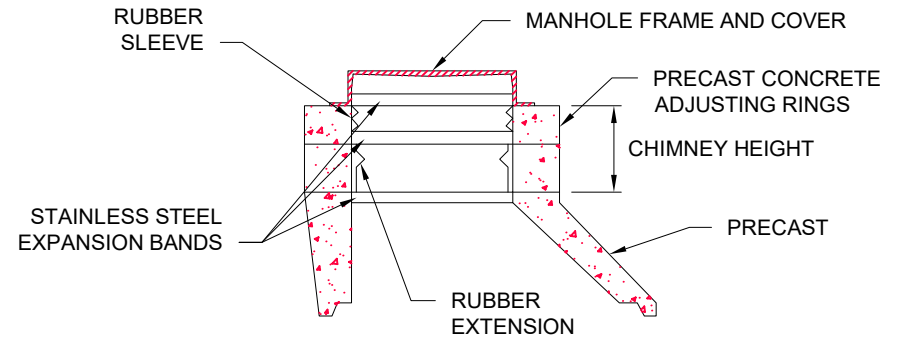

INTERNAL MANHOLE CHIMNEY SEAL

(REQUIRED BY ALL SANITARY APPLICATIONS)
USE CRETEX SPECIALITY PRODUCTS OR EQUAL .

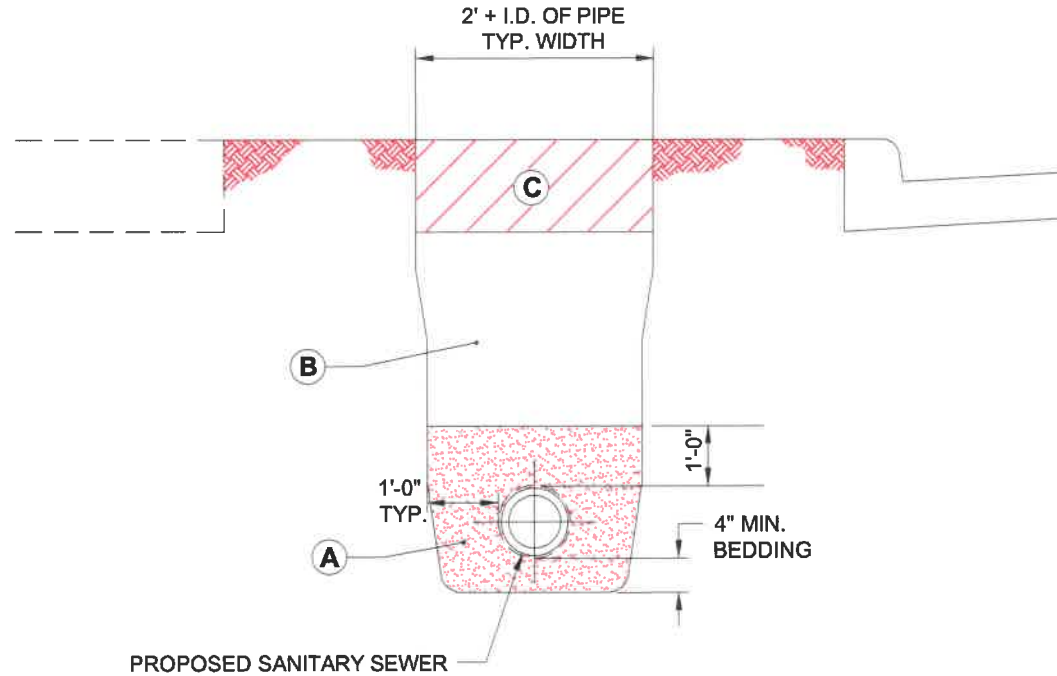

SANITARY SEWER TRENCH DETAIL

SHOWN AS "OFF ROAD" APPLICATION

TRENCH DETAIL NOTES

- A. GRANULAR BEDDING SHALL BE CRUSHED STONE OR GRAVEL, (#57 OR #67), OR OTHER APPROVED EQUIVALENT.
- B. ALL TRENCHES OUTSIDE THE RIGHT-OF-WAY FROM PROPOSED OR EXISTING PAVEMENT, CURB, DRIVEWAYS, ALLEYS, STONE AREAS OR WALKS CAN BE COMPACTED WITH EXISTING NATIVE MATERIAL IN 12 INCH MAXIMUM LIFTS OR AS APPROVED BY THE CITY. NO MATERIAL SHALL BE USED FOR BACK FILLING THAT CONTAINS STONE, ROCKS, ETC., GREATER THAN 4 INCH DIAMETER.

ALL TRENCHES INSIDE THE RIGHT-OF-WAY FROM PROPOSED OR EXISTING PAVEMENT, CURB, DRIVEWAYS, ALLEYS, STONE AREAS OR WALKS SHALL BE COMPACTED WITH GRANULAR BACKFILL MATERIAL TYPE 1 IN 6 INCH MAXIMUM LIFTS.

A DENSITY TEST ON GRANULAR BACKFILL OF 98% OF ASTM D698 STANDARD PROCTOR CURVE MAY BE REQUIRED TO BE PERFORMED BY A COMMERCIAL TESTING LAB SATISFACTORY TO THE CITY.
- C. OFF-PAVEMENT AREAS SHALL BE PROVIDED WITH A MINIMUM OF 6 INCHES OF TOPSOIL OVER THE COMPACTED MATERIAL AND THEN SEEDED AND MULCHED PER ODOT ITEM 659. IN PAVEMENT AREAS SHALL FOLLOW MISCELLANEOUS ROADWAY NOTES SHOWN ON PAGE 300-14.
- D. THE OPEN ENDS OF ALL PIPES SHALL BE PLUGGED TO THE APPROVAL OF THE CITY BEFORE LEAVING THE WORK FOR THE NIGHT.

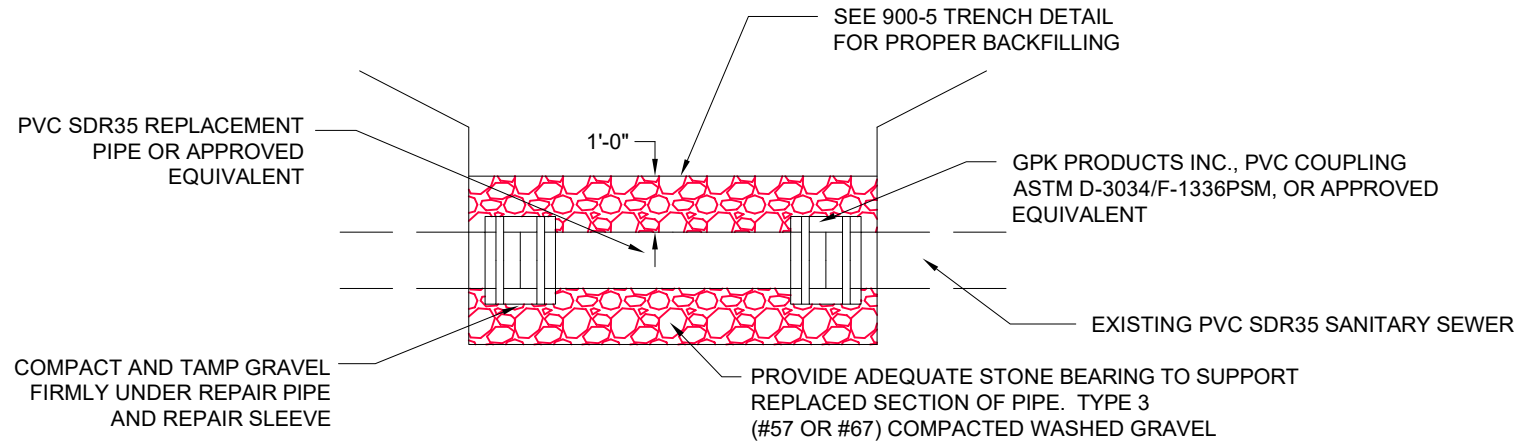

REPAIR OF EXISTING PVC SDR35 SANITARY SEWER

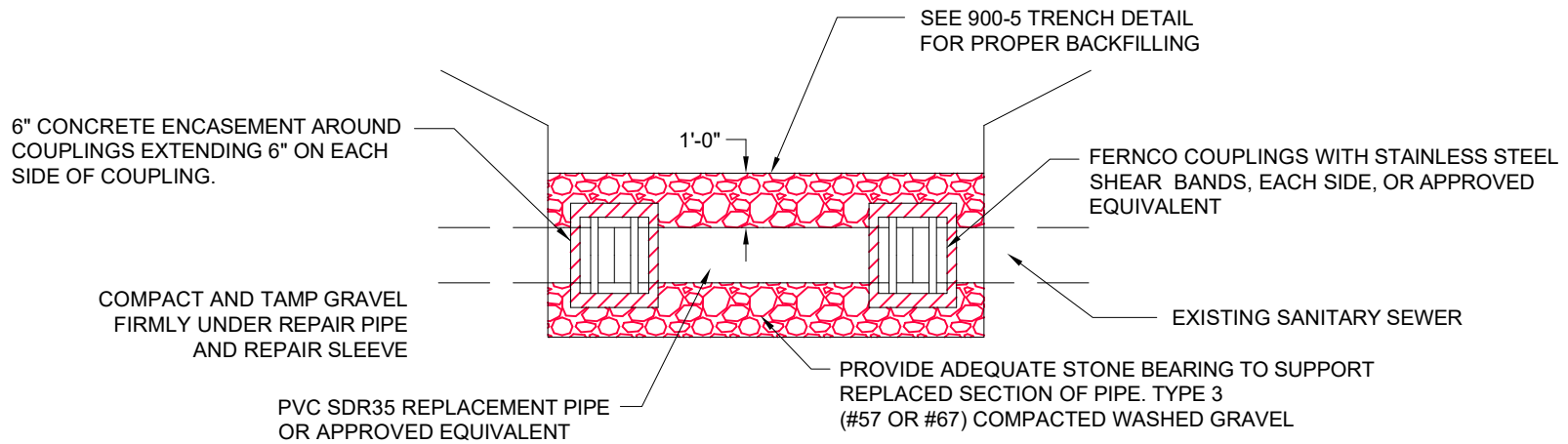

REPAIR OF EXISTING SANITARY SEWER OTHER THAN PVC

CITY OF PIQUA



REPAIR OF EXISTING SANITARY SEWER PIPE DETAIL

REVISIONS:

DATE APPROVED:
DEC. 2016

PAGE No.

900-6

12-29-16 BG

NOTES

- A. A WYE MAY BE CUT IN OR SADDLE WITH PRIOR APPROVAL PLACED ONLY IF AN EXISTING LATERAL IS NOT PROVIDED.
- B. ALL SADDLES AND CUTTING IN WYES MUST BE INSPECTED PRIOR TO COVERING, AND THE HOLE IN THE EXISTING PIPE SHALL BE INSPECTED AND APPROVED PRIOR TO INSTALLATION.
- C. OTHER SADDLE TYPES THAT MAY BE APPROVED ON CASE-BY-CASE BASIS BY ENGINEERING.
- D. ON LOW FLOW AND PVC PIPE SDR 35 USE CUT IN WYE ONLY.

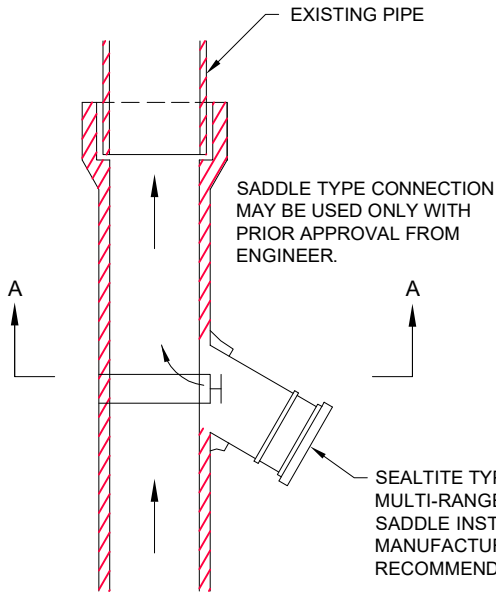

COUPLING (FOR CONNECTIONS DETAIL SEE REPAIR OF EXISTING SANITARY SEWER PIPE DETAIL 900-6).

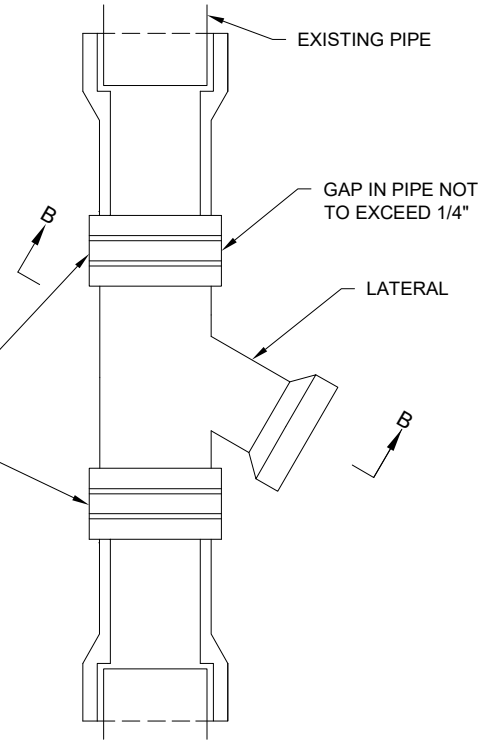

HOLE SHALL BE CAREFULLY CORED AND BE SAME DIAMETER AS OUTSIDE DIAMETER OF LATERAL CONNECTOR.

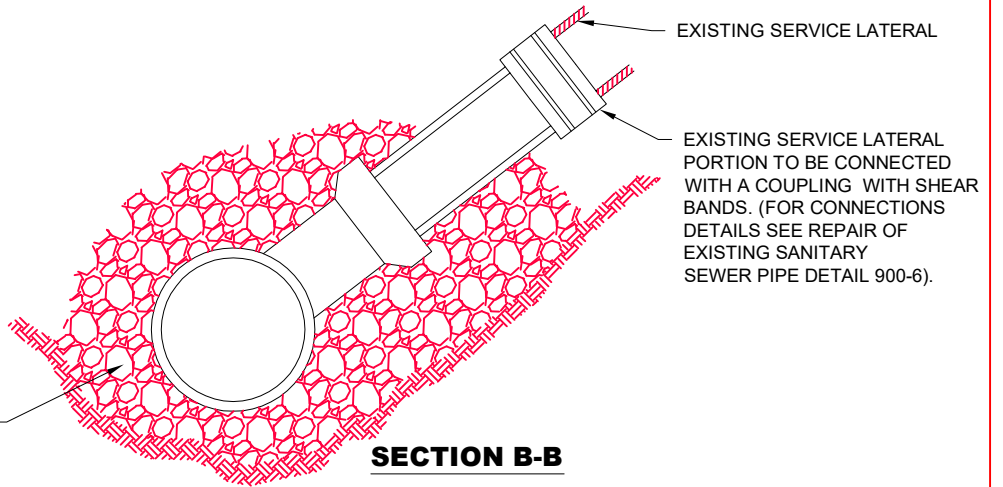
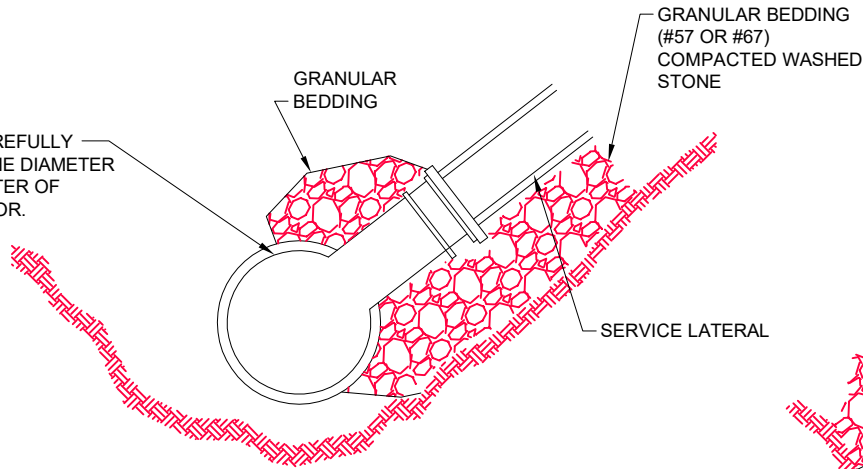

CITY OF PIQUA



SANITARY SEWER SADDLE DETAILS

REVISIONS:

DATE APPROVED:
DEC. 2016

PAGE No.

900-8

12-29-16 BG

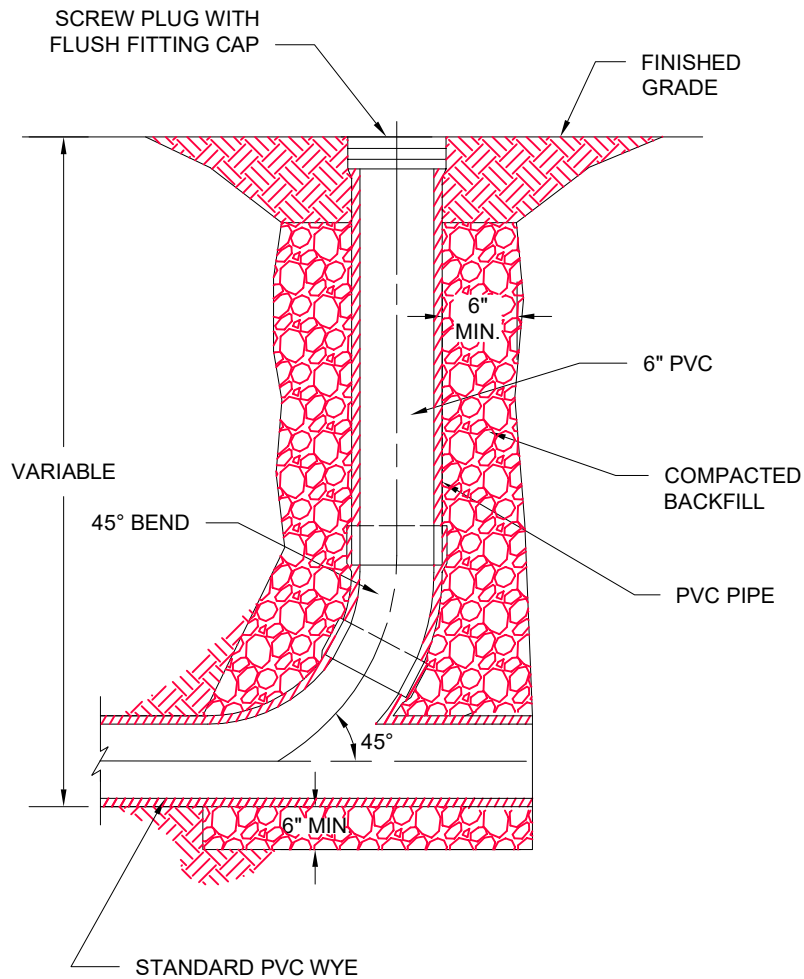

CLEANOUT DETAIL
AT SANITARY LATERALS ONLY

LOW PRESSURE AIR TEST

- A. AFTER BACKFILLING, THE AIR TEST SHALL BE CONDUCTED BETWEEN TWO CONSECUTIVE MANHOLES. ALL PIPE OUTLETS MUST BE PLUGGED IN THE SECTION BEING TESTED WITH A SUITABLE TEST PLUGS. ONE OF THE PLUGS USED AT A MANHOLE MUST BE TAPPED AND EQUIPPED FOR AN AIR INLET CONNECTION FOR FILLING THE LINE FROM THE AIR COMPRESSOR. AIR SHALL BE SUPPLIED SLOWLY TO THE TEST UNTIL THE INTERNAL PRESSURE REACHES APPROXIMATELY 4 PSI. IF THE PIPE IS BELOW EXISTING GROUNDWATER LEVEL, THE INTERNAL PRESSURE SHALL BE INCREASED BY THE AVERAGE BACK PRESSURE OF ANY GROUNDWATER THAT MAY BE OVER THE PIPE, BUT IN NO CASE SHOULD THE INTERNAL PRESSURE EVER EXCEED 5 PSI.
- B. AT LEAST 2 MINUTES SHALL BE ALLOWED FOR THE AIR PRESSURE TO STABILIZE, WHEN THE PRESSURE HAS STABILIZED AND IS AT OR ABOVE 3.5 PSI, THE AIR SUPPLY SHALL BE DISCONNECTED AND TIMING SHALL BEGIN WITH A STOP WATCH. THE STOP WATCH SHALL BE ALLOWED TO RUN UNTIL THE PRESSURE HAS DROPPED 1.0 PSI, IF THE TIME SHOWN ON THE STOP WATCH IS GREATER THAN THE SPECIFIED MINIMUM TIME, THE SECTION SHALL BE CONSIDERED TO HAVE PASSED THE TEST. THE TIME MAY INTERPOLATED FROM THE FIGURES LISTED BELOW

PIPE DIA (IN.)	100FT.	150FT.	200FT.	250FT.	300FT.	350FT.	400FT.
4	1:53	1:53	1:53	1:53	1:53	1:53	1:53
6	2:50	2:50	2:50	2:50	2:50	2:50	2:51
8	3:47	3:47	3:47	3:47	3:48	4:26	5:04
10	4:43	4:43	4:43	4:57	5:56	6:55	7:54
12	5:40	5:40	5:42	7:08	8:33	9:48	11:24
15	7:05	7:05	8:54	11:08	13:21	15:35	17:48
18	8:30	9:37	12:49	16:01	19:41	22:26	25:38
21	9:55	13:05	17:27	21:49	26:11	30:32	34:54
24	11:24	17:57	22:48	28:30	34:11	39:53	45:35

SPECIFICATION TIME FOR LENGTH (L) SHOWN (MIN SEC)

DEFLECTION TEST

- A. DEFLECTION TEST SHALL BE PERFORMED BY THE CONTRACTOR ON ALL FLEXIBLE PIPE. THE TEST SHALL CONDUCTED AFTER THE FINAL BACKFILL HAS BEEN IN PLACE AT LEAST 30 DAYS TO PERMIT STABILIZATION OF THE SOIL -PIPE SYSTEM.
- B. NO PIPE SHALL EXCEED A DEFLECTION OF 5%, IF DEFLECTION EXCEEDS 5% REPLACEMENT OR CORRECTION SHALL BE ACCOMPLISHED IN ACCORDANCE WITH THE REQUIREMENTS OF APPROVING AGENCY.
- C. THE RIGID BALL OR MANDREL USED FOR THE DEFLECTION TEST SHALL HAVE A DIAMETER NOT LESS THAT 95% OF THE BASE INSIDE DIAMETER OR AVERAGE INSIDE DIAMETER OF THE PIPE DEPENDING ON WHICH IS MANUFACTURED. THE PIPE SHALL BE MEASURED IN COMPLIANCE WITH ASTM D-2122 STANDARD TEST METHOD OF DETERMINING DIMENSIONS OF THERMOPLASTIC PIPE AND FITTINGS. THE TEST SHALL BE PERFORMED WITH MECHANICAL PULLING DEVICES.

DEPTH (FT)	48 TIME	60 SECONDS	72
8 OR LESS	20	26	33
10	25	33	41
12	30	39	49
14	35	46	57
16	40	52	67
18	45	59	73
20	50	65	81
22	55	72	89
24	59	78	97
26	64	85	105
28	69	91	113
30	74	98	121

MINIMUM TEST TIMES FOR VARIOUS MANHOLE DIAMETERS

MANHOLE VACUUM TEST

ALL SANITARY SEWER MANHOLES SHALL BE VACUUM TESTED BY THE CONTRACTOR USING THE FOLLOWING PROCEDURES FROM ASTM C-1244.

- A. PREPARATION OF THE MANHOLE
- ALL LIFT HOLES SHALL BE PLUGGED.
 - ALL PIPES ENTERING THE MANHOLE SHALL BE TEMPORARILY PLUGGED TAKING CARE TO SECURELY BRACE THE PIPES AND PLUGS TO PREVENT FROM BEING DRAWN INTO THE MANHOLE.
- B. PROCEDURE
- THE FIRST HEAD SHALL BE PLACED AT THE TOP OF THE MANHOLE IN THE CASTING IN ACCORDANCE WITH THE MANUFACTURE'S RECOMMENDATIONS.
 - A VACUUM OF 10 INCHES OF MERCURY (4.9 PSI) SHALL BE DRAWN ON TH MANHOLE, THE VALVE ON THE VACUUM LINE OF THE TEST HEAD CLOSED, AND THE VACUUM PUMP SHUT OFF. THE TIME SHALL BE MEASURED FOR THE VACUUM TO DROP TO 9 INCHES OF MERCURY (4.4PSI)
 - THE MANHOLE SHALL PASS IN THE TIME FOR THE VACUUM READING TO DROP FROM 10 INCHES OF MERCURY (4.9 PSI) MEETES OR EXCEEDS THE VALUES INDICATED ON THE TABLE.
 - IF THE MANHOLE FAILS THE INITIAL TEST, NECESSARY REPAIRS SHALL BE MADE BY AN APPROVED METHOD. THE MANHOLE SHALL BE RETESTED UNTIL A SATISFACTORY TEST IS OBTAINED.

ALL TESTS SHALL BE WITNESSED BY A CITY OF PIQUA ENGINEERING DEPARTMENT REPRESENTATIVE

SEWER TELEVISION STANDARDS

- A. ALL SEWER TELEVISION CONTRACTORS SHALL BE CERTIFIED BY NASSCO FOR PIPELINE ASSESMENT AND CERTIFICATION.
- B. SANITARY TELEVISION WORK SHALL COMPLY WITH NASSCO STANDARDS.
- C. ALL TELEVISION WORK SHALL BE COMPLETED IN COLOR WITH THE PROPER AMOUNT OF ILLUMINATION TO CLEARLY SHOW THE ENTIRE PIPE DIAMETER.
- D. THE CAMERA SHALL BE OF THE PAN AND TILT TYPE
- F. AT THE START OF THE TELEVISION PROCESS, THE DVD
 - 1. DATE/TIME
 - 2. OPERATOR AND COMPANY NAME
 - 3. SEWER PROJECT NAME
 - 4. ADDRESS OR INTERSECTION OF MANHOLE WORKING ON
 - 5. DIRECTION OF TELEVISION
 - 6. COUNTER SETTING.
- G.. THE DVD MUST SHOW THE COUNTER RECORDING THROUGHOUT THE TELEVISION PROCESS.
- H. THE DVD SHALL SHOW THE CLOCK POSITION AND DISTANCE FROM THE MANHOLE FOR EACH LATERAL
- I. THE OPERATOR SHALL PAN EACH SEWER JOINT AND NOTE ANY DEFICIENCIES ON THE MAIN SCREEN.
- J. THE OPERATOR SHALL POSITION THE CAMERA TO LOOK UP EACH LATERAL CONNECTION.
- K. AT NO TIME SHALL THE OPERATOR ALLOW THE CAMERA HEAD TO BE SUBMERGED.
- L. THE OPERATOR SHALL NOTE ANY DEFICIENCIES ON THE MAIN SCREEN.
- M. THE OPERATOR SHALL KEEP AN ACCURATE LOG CONSISTING OF THE FOLLOWING;
 - 1. DIAGRAM OF SEWER FROM MANHOLE TO MANHOLE SHOWING DIRECTION OF FLOW.
 - 2. SHALL NOTATE ALL SEWER LATERALS WITH CLOCK POSITIONS AND DISTANCE FROM MANHOLES
 - 3. DEFICIENCIES IN THE SEWER PIPE INCLUDING BELLIES
 - 4. SPECIAL NOTES DESCRIBING AREAS OF CONCERN.
 - 5. ANY DEFICIENCIES NOTED SHALL ACCOMPANY A DIGITAL PHOTO ATTACHED ON INCLUDED IN THE REPORT.

STANDARDS FOR BELLIES/DIPS IN SEWER MAINS

SANITARY SEWERS SHALL BE DECLARED AS "NOT APPROVED" IF DIPS/BELLIES IN THE MAIN LINE EXCEEDS THE FOLLOWING CRITERIA
 MAXIMUM ALLOWABLE BELLIES IN PIPE (INCHES)

SLOPE	8"	10"	12"	15"	18"	21"	24"	>27"
0.10%	2"	2.5"	3"	4"	4"	4"	4.5"	5"
0.12%	2"	2.5"	3"	4"	4"	4"	5"	5"
0.15%	2"	2.5"	3"	3.5"	3.5"	4"	4"	4"
0.22%	2"	2.5"	3"	3"	3.5"	3.5"	3.5"	4"
0.28%	2"	2"	2"	2"	2.5"	2.5"	3"	3"
0.40%	2"	2"	2"	2"	2"	2.5"	2.5"	2.5"
0.60%	1"	1"	1"	1"	1"	1"	1"	1"
1.00%	0"	0"	0"	0"	0"	0"	0"	0"

SEWER TELEVISION PROCEDURES FOR NEW SEWER CONSTRUCTION

- A. THE SANITARY SEWER SHALL BE COMPLETELY CLEAN AND FREE OF DEBRIS USING A HIGH PRESSURE JET RODDER CAPABLE OF SCOURING THE PIPE WALLS.
- B. ALL DEBRIS SHALL BE VACUUMED OUT OF THE SEWER MAIN.
- C. ONCE CLEANING HAS BEEN COMPLETED, THE CONTRACTOR SHALL RUN CLEAR WATER IN THE NEW SEWER MAIN TO FILL ANY POTENTIAL BELLIES IN THE LINE. THE CONTRACTOR SHALL CALCULATE THE VOLUME GALLON CAPACITY OF THE SEWER MAIN AND SHALL USE THAT MUCH WATER TO FILL POTENTIAL DIPS/BELLIES.
- D. THE CONTRACTOR MAY RENT A WATER HYDRANT METER FROM THE CITY TO PERFORM THIS TASK.
- E. THE CONTRACTOR SHALL MAKE SURE THAT THERE IS NO FLOW EMANATING UPSTREAM. IF SO THE CONTRACTOR SHALL STOP THIS FLOW DURING THE TELEVISION PROCESS.
- F. THE CONTRACTOR SHALL TELEVISION THE SEWER FOLLOWING THE TELEVISION STANDANDRS.

SEWER TELEVISION PROCEDURES FOR SEWER RECONSTRUCTION PROJECTS

- A. BEFORE COMMENCEMENT OF THE CLEANING PROCESS, THE TELEVISION CONTRACTOR SHALL NOTIFY ADJACENT AND AFFECTED PROPERTY OWNERS BY GOING DOOR TO DOOR AND NOTIFYING THEM OF THE POSSIBILITY OF SEWER BACKUP DURING THE CLEANING PROCESS.
 - B. THE SANITARY SEWER SHALL BE COMPLETELY CLEAN AND FREE OF DEBRIS USING A HIGH PRESSURE JET RODDER CAPABLE OF SCOURING THE PIPE WALLS.
 - C. ALL DEBRIS SHALL BE VACUUMED OUT OF THE SEWER MAIN.
 - D. ONCE CLEANING HAS BEEN COMPLETED, THE CONTRACTOR SHALL BAG THE UPSTREAM MANHOLE AND PUMP THE SEWAGE FLOW DOWNSTREAM AND SHALL MAINTAIN PUMPING DURING THE TELEVISION PROCESS. THE CONTRACTOR SHALL BE RESPONSIBLE FOR ANY SEWER FLOODINGS AS A RESULT OF THEIR ACTIVITIES.
 - E. AFTER THE PUMP BYPASS HAS BEEN ESTABLISHED, THE CONTRACTOR SHALL RUN CLEAR WATER IN THE RECONSTRUCTED SEWER MAIN TO FILL ANY POTENTIAL BELLIES IN THE LINE. THE CONTRACTOR SHALL CALCULATE THE VOLUME GALLON CAPACITY OF THE SEWER MAIN AND SHALL USE THAT MUCH WATER TO FIILL POTENTIAL DIPS/BELLIES.
 - F. THE CONTRACTOR MAY RENT A WATER HYDRANT METER FROM THE CITY TO PERFORM THIS TASK.
 - G. THE CONTRACTOR SHALL TELEVISION THE SEWER FOLLOWING THE TELEVISION STANDARDS
- PASSING SANITARY SEWER**
- A. THE CITY WILL NOT PASS OR ACCEPT THE SANITARY SEWER FOR FINAL PAYMENT WITHOUT HAVING A PASSING DVD AND LOG OF THE SANITARY SEWER TELEVISION FOLLOWING THE STANDARDS PREVIOUSLY DESCRIBED.
 - B. ALL TELEVISION WORK SHALL BE AT THE CONTRACTORS EXPENSE.
 - C. THE CITY RESERVES THE RIGHT TO FINAL RE-TELEVISION AT THE CONTRACTORS EXPENSE IF DEFICIENCIES ARE NOTED ON THE INITIAL TELEVISION WORK AND AFTER THE CONTRACTOR MAKES THE NECESSARY REPAIRS.

NOTES

- A. NO WORK SHALL BE APPROVED OR ACCEPTED BY THE CITY UNLESS 2 WORKING DAYS NOTICE OF COMMENCING WORK IS GIVEN TO THE CITY.
- B. ALL TEMPORARY PAVEMENT AND SIDEWALK SHALL BE MAINTAINED BY THE CONTRACTOR OR DEVELOPER AT HIS OWN EXPENSE IN A SUITABLE AND SAFE CONDITION FOR TRAFFIC UNTIL PERMANENT PLACEMENT IS MADE OR THE PROJECT IS FINALLY ACCEPTED BY THE CITY.
- C. ROOF DRAINS, FOUNDATION DRAINS, SUMP PUMPS, AND ALL OTHER CLEAR WATER CONNECTIONS TO THE SANITARY SEWER SYSTEM ARE PROHIBITED.
- D. WHEN A SEWER IS TO BE EXTENDED AT THE DOWNSTREAM MANHOLE OR FIRST MANHOLE IS THE NEW LINE, IT SHALL BE PLUGGED BEFORE CONSTRUCTION BEGINS. NO PLUGS SHALL BE REMOVED UNTIL CONSTRUCTION IS COMPLETED AND SOIL IS STABILIZED AND THEN ONLY AS DIRECTED BY THE CITY .
- E. CONSTRUCTION OF SANITARY SEWERS SHALL INCLUDE THE CITY DYE TESTING AS DETERMINED BY THE CITY OF ALL PIPES TO BE CONNECTED TO THE NEW SEWER PRIOR TO BACKFILLING.
- F. WHEN A CASTING OR OTHER PUBLIC PROPERTY IS ABANDONED IT REMAINS CITY PROPERTY, UNLESS OTHERWISE DIRECTED.
- G. SANITARY SEWERS MUST HAVE EPA PLAN APPROVAL OR ANY SANITARY SEWER THAT IS RELOCATED OR RESIZED.

EXCAVATION AND PIPE LAYING

- A. THE LAYING OF THE PIPE SHALL COMMENCE AT THE LOWEST POINT, THE THE BELL END LAID UPGRADE. THE PIPE SHALL BE CENTERED IN THE TRENCH AND ALL PIPE SHALL BE LAID WITH ENDS ABUTTING AND TRUE TO LINE AND GRADE.
- B. LASER SHALL BE USED INSIDE THE PIPE.

UTILITY STAKING

- A. LASER METHOD- OFFSET AND GRADE AT EACH MANHOLE, OFFSET AND GRADE 50 FEET AND 100 FEET OUT FROM EACH MANHOLE UNLESS OTHERWISE APPROVED.

TESTING- ALL PHASES PERFORMED BY CONTRACTOR OR DEVELOPER

- A. BEFORE ANY SEWER LINE IS PLACED INTO SERVICE OR ACCEPTED BY THE CITY, IT SHALL BE SUBJECTED TO AND PASS LOW PRESSURE AIR TEST. EACH RUN BETWEEN MANHOLES, WITH SERVICE LATERALS STUBBED INTO PROPERTY LINES, SHALL BE TESTED BEFORE BEING ACCEPTED. THE CONTRACTOR OR DEVELOPER SHALL FURNISH ALL EQUIPMENT AND MATERIAL NECESSARY TO CONDUCT THIS TEST. THE TRENCH SHALL BE COMPLETELY BACKFILLED BEFORE TESTING.
- B. SEE SANITARY SEWER TESTING NOTES (PAGE 900-11)
- C. BEFORE FINAL ACCEPTANCE BY THE CITY AND BEFORE ANY SERVICE LINE IS PUT INTO USE, ALL SANITARY SEWER AND MANHOLES SHALL BE THOROUGHLY CLEANED OF ALL FOREIGN MATTER BY USE OF A SEWER-JET OR EQUAL, TYPE OF EQUIPMENT BY THE CONTRACTOR. SEWER JET PROCEDURE MUST BE PERFORMED BEFORE CONTRACTOR T.V. TESTS THE PIPE.
- D. SEE SANITARY SEWER TESTING NOTES (PAGE 900-12)

HOUSE CONNECTIONS

- A. NO SERVICE LINE SHALL BE ALLOWED TO CONNECT DIRECTLY INTO A MANHOLE, SUBJECT TO APPROVAL BY THE CITY IN SPECIFIC CASES.
- B. THE ENDS OF ALL SERVICES LINES OR TEES SHALL BE ACCURATELY LOCATED, MAPPED AND GIVEN TO THE CITY WITHIN 15 DAYS AFTER INSTALLATION.
- C. BEFORE MAKING A CONNECTION TO AN EXISTING SEWER TAP OR SEWER LATERAL, THE CONTRACTOR SHALL CHECK THE EXISTING PIPE BY UTILIZING A SEWER EEL, STRAP, OR A ROD TO SEE THAT THE EXISTING PIPE IS CONNECTED TO THE MAIN SEWER. IF NEEDED, THE CONTRACTOR MAY NEED TO USE A HYDRAULIC SEWER CLEANER.

- D. LATERALS FROM THE MAIN TO THE PROPERTY LINE SHALL BE 6 INCHES MINIMUM WITH CLEANOUT AT THE PROPERTY LINE.
- E. A RIGHT-OF-WAY PERMIT TO OPEN INTO, ALTER, OR DISTURB ANY PUBLIC SEWER MUST BE OBTAINED.
- F. IN THE DEMOLITION OF EXISTING BUILDING, ALL ABANDONED SEWER LATERALS SHALL BE CAPPED AT THE OWNER'S EXPENSE.

PIPE

- A. ALL MAINLINE PIPE AND SPECIALS SHALL BE PVC SDR-35 UNLESS OTHERWISE APPROVED BY THE CITY. MINIMUM DIAMETER OF PIPE SHALL BE 8 INCHES.
- B. DUCTILE IRON PIPE WILL BE USED IN STREAM CROSSINGS AND WHERE MAXIMUM SEPARATION CANNOT BE MAINTAINED OR WHEN THE DEPTH OF SEWER EXCEEDS 25 FEET.
- C. ALL JOINTS SHALL BE OF THE BELL AND SPIGOT TYPE, THE BELLS BEING FORMED INTEGRALLY WITH THE PIPE. THE BELL SHALL CONTAIN A FACTORY INSTALLED ELECTROMETRIC GASKET WHICH IS POSITIVELY RETAINED. NO SOLVENT CEMENT JOINTS WILL BE PERMITTED IN FIELD CONSTRUCTION EXCEPT AS SPECIFICALLY AUTHORIZED BY THE CITY.

FLEXIBLE PIPES	MATERIAL SPECIFICATIONS	JOINT SPECIFICATIONS
POLYVINYL CHLORIDE	ASTM D-3034 (SDR-35) PIPE STIFFNESS= 46 PSI	ELASTOMERIC GASKET ASTM D-3212
DUCTILE IRON	ANSI A-21.51 & AWWA C-151	ANSI A-21.11 AWWA C-111
1. SDR= OUTSIDE DIAMETER DIVIDED BY WALL THICKNESS.		
2. THE SPECIFICATIONS ABOVE SHALL BE THOSE MOST RECENTLY ADOPTED BY THE APPROPRIATE STANDARDS SETTING ORGANIZATION.		

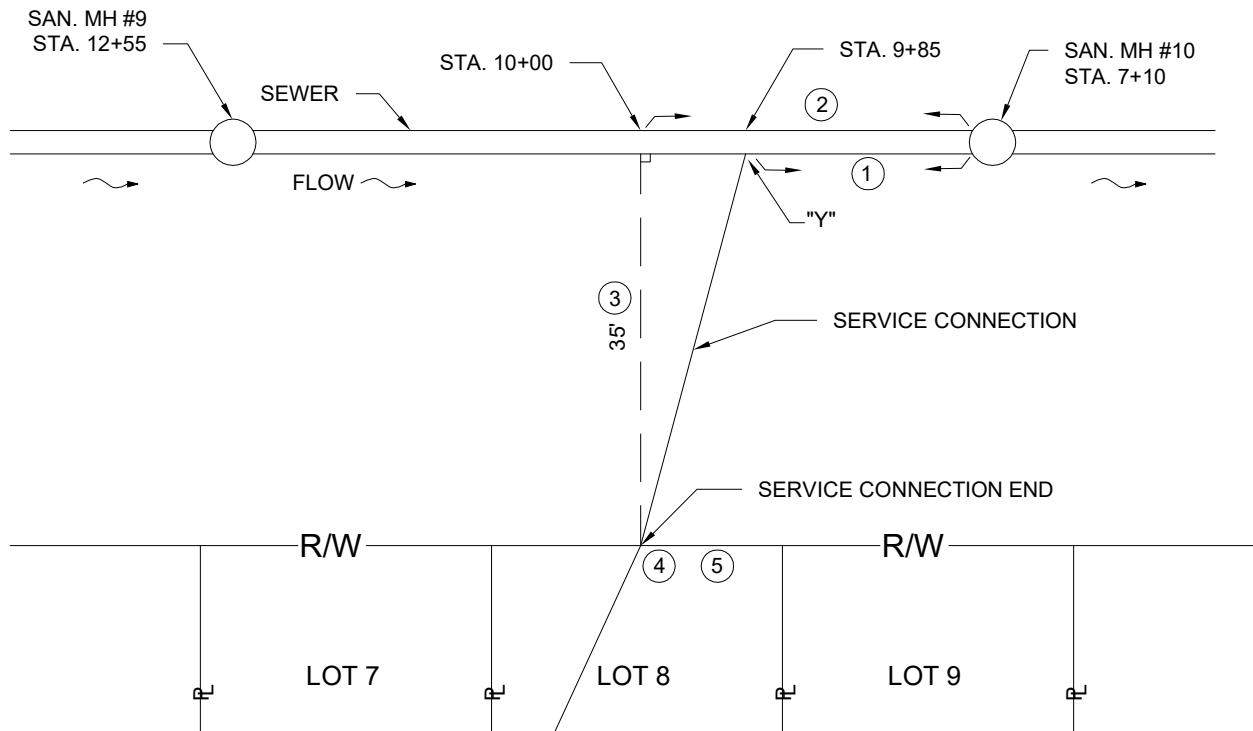

EXAMPLE

- 1. 275'
- 2. 290'
- 3. 35'
- 4. 8.9'
- 5. 942.9

THE CONTRACTOR SHALL SUPPLY THE FOLLOWING INFO TO THE SATISFACTION OF THE CITY

- ① HORIZONTAL DISTANCE OF TEE TO DOWNSTREAM MANHOLE.
- ② HORIZONTAL DISTANCE OF SERVICE CONNECTION END TO DOWNSTREAM MANHOLE ALONG SEWER.
- ③ PERPENDICULAR DISTANCE FROM SEWER TO SERVICE CONNECTION END.
- ④ DEPTH OF SERVICE CONNECTION END FLOW LINE TO ORIGINAL GROUND.
- ⑤ ELEVATION OF SERVICE CONNECTION END FLOW LINE.
- ⑥ ELEVATION OF BACK OF CURB OR SOME OTHER REFERENCE POINT ABOVE LATERAL.

CITY OF PIQUA



SERVICE CONNECTION LOCATION REFERENCE

REVISIONS:

DATE APPROVED:
DEC. 2016

PAGE No.

12-30-16 BG

900-14

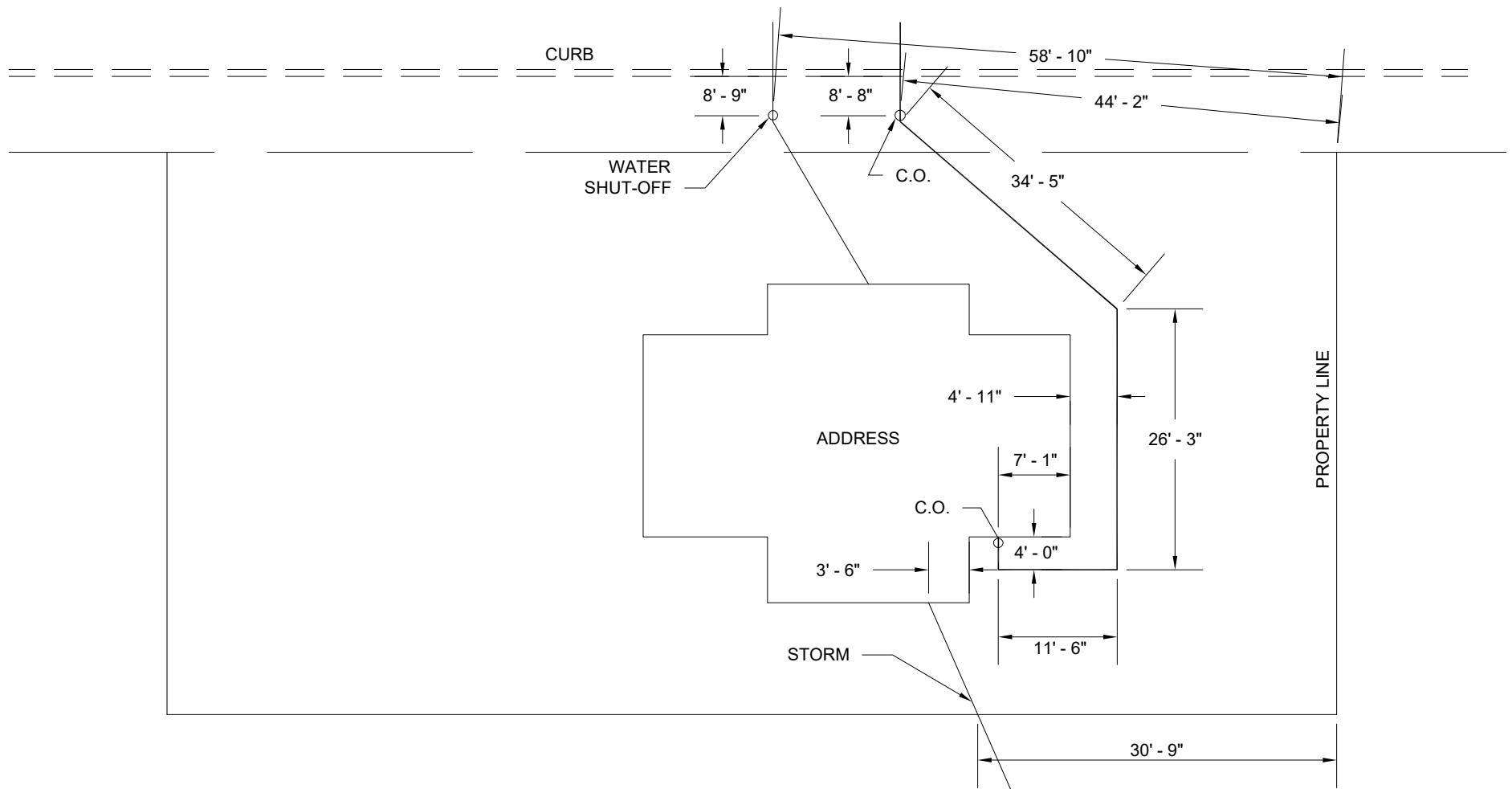

TO BE COMPLETED BY THE CONTRACTOR FOR EACH BUILDING SEWER

SAMPLE SITE SKETCH. GIVE DIMENSIONS FOR ALL UNDERGROUND PIPES. MAKE A DIFFERENT SKETCH FOR EACH UTILITY, IF NEEDED. FOR EXAMPLE, IF THIS HOUSE HAD DOWN SPOUT LEADERS, A SEPARATE STORM SHEET WOULD BE NEEDED.

CITY OF PIQUA

**SERVICE CONNECTION LOCATION REFERENCE
(BUILDING IN PLACE)**



REVISIONS:

DATE APPROVED:
DEC. 2016

PAGE No.
900-15

12-30-16 BG

MAINTENANCE OF FLOW IN EXISTING SEWERS AND DRAINS

1.01 SCOPE OF WORK

- A. FURNISH ALL LABOR, MATERIALS, EQUIPMENT AND INCIDENTALS REQUIRED TO MAINTAIN WASTEWATER AND /OR STORM DRAINAGE FLOW IN ALL PUBLIC AND PRIVATE PIPES, INCLUDING INDIVIDUAL SERVICE CONNECTIONS, DURING CONSTRUCTION.
- B. CONSTRUCT AND MAINTAIN ALL TEMPORARY BYPASS SEWERS AND DRAINS AND BE RESPONSIBLE FOR ALL BYPASS PUMPING OF SEWAGE AND DRAINAGE THAT MAY BE REQUIRED TO PREVENT BACKING UP OF SEWAGE AND ALLOW FOR PROPER INSPECTION, REHABILITATION, TESTING, OR DRAINAGE DURING PIPE REPLACEMENT, INSTALLATION OF NEW PIPE LINING, OR RELATED REHABILITATION WORK. THE CONTRACTOR SHALL IMMEDIATELY REMOVE AND DISPOSE OF ALL OFFENSIVE MATTER SPILLED DURING THE BYPASS PUMPING AT HIS OWN EXPENSE.

1.02 SUMMITTALS

- A. THE CONTRACTOR SHALL SUBMIT TO THE ENGINEER A SCHEDULE TO COMPLETE THE WORK. IT WILL INCLUDE THE SEQUENCING AND COORDINATION OF PIPELINE CLEANING, INSPECTION, REHABILITATION, CONSTRUCTION, TESTING, MAINHOLE REHABILITATION, AND THE HANDLING OF WASTEWATER FLOW AND DRAINAGE DURING THESE ACTIVITIES.
- B. THE CONTRACTOR SHALL SUBMIT TO THE ENGINEER, FOR APPROVAL, A DETAILED WRITTEN PLAN OF ALL METHODS OF FLOW MAINTENANCE TEN (10) DAYS IN ADVANCE OF FLOW INTERRUPTION. ALL PROCEDURES FOR MAINTAINING FLOWS, INCLUDING WEEKEND OPERATIONS AND OTHER EXTENDED PERIODS OF TIME, MUST MEET THE APPROVAL OF THE ENGINEER.

1.03 EXECUTION

WHEN THE BYPASS PUMPING IS REQUIRED THE CONTRACTOR SHALL SUPPLY ALL NECESSARY PUMPS, PIPING, CONNECTIONS, AND TEMPORARY POWER REQUIRED TO DIVERT THE FLOW OF SEWAGE OR DRAINAGE AROUND THE AREA IN WHICH WORK IS BEING PERFORMED. THE BYPASS SYSTEM SHALL BE OF SUFFICIENT CAPACITY TO HANDLE EXISTING FLOWS PLUS ADDITIONAL FLOW THAT MAY OCCUR DURING A RAIN EVENT

- A. THE CONTRACTOR SHALL SUPPLY COMPLETELY REDUNDANT BYPASS PUMPING FOR CAPACITY IN THE EVENT OF PUMP FAILURE.
- B. INFLATABLE PLUGS OR TEMPORARY DAMS MAY BE INSTALLED IN THE SANITARY OR STORM DRAINAGE SYSTEM TO TEMPORARILY BLOCK THE FLOW ON THE SUCTION SIDE OF THE BYPASS PUMPING SETUP.
- C. THE SUCTION OR DISCHARGE PIPING OR TUBING FROM A BYPASS PUMPING SETUP SHALL NOT ADVERSELY INTERFERE WITH PEDESTRIAN OR VEHICULAR TRAFFIC.
- D. DISCHARGE FROM THE BYPASS PUMPING SETUP SHALL BE BELOW GROUND AND PREFERABLY INTO THE NORMAL FLOW PATH OF THE RECEIVING SANITARY SEWER TO DEDUCE ODORS
- E. ALL FLOWS FROM ALL PUBLIC, PRIVATE, COMMERCIAL, AND INDUSTRIAL USERS SHALL BE HANDLED WITHOUT INTERRUPTION BY THE CONTRACTOR DURING REHABILITATION OF THE SANITARY OR STORM DRAINAGE SYSTEM.
- F. THE CONTRACTOR SHALL BE REQUIRED TO REPAIR AT HIS OWN EXPENSE ANY DAMAGE TO PUBLIC PROPERTY, PRIVATE PROPERTY, OR THE SANITARY AND STORM DRAINAGE SYSTEM CAUSED BY HIS OPERATIONS.
- G. THE CONTRACTOR SHALL NOT BE PERMITTED TO OVERFLOW, BYPASS, PUMP OR BY ANY OTHER MEANS CONVEY DRAINAGE TO ANY LAND, STREET, STORM DRAIN OR WATER COURSE.